

Wexiödisk^W



rosg
grupo

Wexiödisk^W



ro/g
grupo

Contents

WEXIÖDISK QUALITY, GREEN THINKING & ERGONOMICS	5
WD-4S THE BEST BAR DISHWASHER IN TOWN.....	6
IZAKAYA MOSHI A LOVE OF JAPANESE CUISINE	8
WD-6 AND WD-7 A KITCHEN STAPLE.....	10
PRM PRE-RINSE MACHINE	12
THE NAGG RESTAURANT LIMITED SPACE YET GREAT RESULTS.....	14
DUPLUS WASH WITH ONE LITRE OF FRESH WATER.....	16
ECO-FLOW HEAT RECOVERY	16
SAVE MORE	17
OVERVIEW	18



Intertek

Wexiödisk is a certified company and complies with the following rules, regulations and standards:

- ISO 9001
- ISO 14001
- DIN 10512
- EN 1717
- The Machinery Directive, CE marking



*Every installation
should be
a good reference.*

Can you combine quality, green thinking and ergonomics?

At Wexiödisk our answer to this question is yes! We call it eco-design. Since we started in 1972 our philosophy has been to work with a focus on quality and sustainability and with the environment as a starting point. Without, of course, forgoing ergonomics and a good working environment.

Our vision is a circular economy, which means that the economic cycle is not linear but rather circular, with the focus on sustainable development. Wexiödisk develops high-quality products and carefully selects each component. All to help prolong a product's life cycle and conserve natural resources. Our ethos has always been that every dishwasher we develop should be more resource-efficient than the previous model. For us, a circular economy is:

- **A functional stainless steel design that delivers sustainability and a long service life.**
- **Servicing is normally carried out from the front of the machine. Components can be accessed more easily, making servicing quicker.**
- **We think about the person! Improved ergonomics, e.g. through Autostart, with automatic opening and closing of the hood, reduces repetitive strain injuries and makes the washing process considerably easier.**
- **Our patented innovations, PRM and DUPLUS, help you to reduce the environmental impact of your kitchen. PRM and DUPLUS are available as options on a number of our machines (see page 12).**
- **All our dishwashers have the option of ECO-FLOW heat recovery, which effectively saves energy and improves the climate in the dishwashing room (see page 16).**
- **We are continuously working to develop new solutions in order to save even more water and energy and further reduce the need for chemicals.**

➤ PURSUING A CIRCULAR ECONOMY HAS BEEN AN ELEMENT OF OUR SMÅLAND BRAND SINCE WE STARTED IN 1972.

WD-4S

– compact, stylish and efficient

If you want a reliable and efficient under-counter dishwasher, then WD-4S is a smart choice. The Swedish design characterised by quality, functionality and clean lines is evident in every detail, meaning there's no need to hide WD-4S away.

HIGH-QUALITY SWEDISH DESIGN

The WD-4S dishwasher is designed to function optimally in as many kitchens as possible, and you can even install it in a bar or café. A clean design with limited details and smooth, rounded corners means improved hygiene and cleaner results. Furthermore, the door can be placed in a hygienic position that prevents the growth of bacteria when the machine is not in use.

WHICH MODEL WORKS FOR YOU?

In addition to our basic-level machine BASIC, WD-4S is also available in a GLASS model that has been specially designed for washing glasses. The glasses are tilted in the open washing basket in such a way that less water collects on the foot of the glass and water does not run along its surface. The water jets reach all parts of the glass and drying results have also been improved. WD-4S GLASS also features three specific glass washing programmes, where the washing time and water quantity have been adapted for different types of glasses. For example, there is a low temperature rinse that rapidly cools beer glasses for immediate use. Choose ECO-FLOW to save energy and improve the working environment. *Read more on page 16.*



CLEAN, SIMPLE AND FUNCTIONAL DESIGN IN STAINLESS STEEL

STAINLESS STEEL SIDE PLATES ARE INCLUDED, ENABLING WD-4S TO BE COMPLETELY FREESTANDING

WD-4S CAN WASH UP TO 50 BASKETS PER HOUR, I.E. 1,000 GLASSES, 900 PLATES OR 450 TRAYS



ECO-FLOW HEAT RECOVERY SAVES ENERGY AND REDUCES DRYING TIME

LIFETIME GUARANTEE FOR THE MAIN PIPE



SELF-EXPLANATORY AND ANGLED TOUCH DISPLAY IN TEMPERED GLASS. THE DISPLAY ALSO WORKS IF YOU ARE WEARING GLOVES OR HAVE WET HANDS

SPECIALLY DESIGNED WASHING ARMS CLEAN EVERY MILLIMETRE OF THE DISHWARE

➤ BASIC PROGRAMME

Programme 1: Glasses and cups, total washing time 1.2 min.*

Programme 2: Plates, total washing time 2.4* min.

Programme 3: Cutlery and pots, total washing time 4.2* min.

➤ GLASS PROGRAMME

Programme 1: Beer glasses, total washing time 1.2 min.* with lower final rinse temperature, 65°C.

Programme 2: Standard glasses, total washing time 1.2* min., final rinse temperature 85°C.

Programme 3: Wine glasses, total washing time 2.2* min., final rinse temperature 65°C and increased water quantity for final rinse.

*Factory setting. The washing time can be adjusted.

The bar dishwasher

that makes work easier

SMART DISPLAY

With three programmes, the WD-4S is easy to use. The self-explanatory and sloping display in tempered glass provides a clear overview of the washing time from a distance. Colours indicate the status of the wash and a sound indicates when washing is complete. The smart display also works if you are wearing gloves or have wet hands.

GOOD HYGIENE LEVELS

With the new WD-4S the door can be placed in a spacesaving hygienic position that prevents the growth of bacteria when the machine is not in use, e.g. over long weekends or during holidays.

VERSATILE AND EFFICIENT

A push of a button allows you to easily replace the water so you can switch between washing dirty plates and washing glasses and trays. Having the two functions in the same machine saves both space and time.



Both WD-4S BASIC and GLASS are available with a bottom frame (lockable or open) with guide rails for three baskets.



Izakaya moshi

– a love of Japanese cuisine

Izakaya moshi was opened in December 2012 by Sandra Bertilsson and Daniel Djurvall.

“We wanted the people of Växjö to have a Japanese restaurant serving food with clean flavours and beautiful colours.”

Izakaya, which means ‘slink in’ in Japanese, seats 70, and the restaurant has received numerous accolades, including a listing in White Guide 2016.

WHEN FOOD BECOMES AN EXPERIENCE

There are no secrets in the open kitchen. The restaurant’s sole purpose is to convey a love of Japan’s fantastic cuisine. Izakaya moshi uses locally produced ingredients from farms in the surrounding area.

“We have also been incredibly lucky in employing excellent staff, both for front of house duties and in the kitchen. Our chefs are extremely creative, and enjoy experimenting and developing our food concept, enabling us to con-

stantly surprise our diners with new colours, shapes and flavours. A complete experience that focuses on food – it’s that simple!”

CLEANER GLASSES WITH WD-4S

Just recently the restaurant invested in a new under-counter dishwasher from Wexiödisk, a WD-4S.

“It is sooooo good and sooooo clean! The flow in the bar has changed completely, and we can keep dirty dishes out of the sinks. Everything is much more hygienic,” says Sandra. “We opted for a glasswasher model, with two special glass washing baskets. The glasses are tilted in the basket, which leaves them drier after washing. We also don’t need to wipe any water marks from them. We use the machine to wash other bar accessories, too.

“As the WD-4S is located in the bar, it is important for it to operate silently. There’s no unnecessary rattling from this dishwasher. We chose Wexiödisk because we already have a WD-6, which is older than me!” concludes Sandra.



“We chose Wexiödisk because we already have a WD-6, which is older than me!”

SANDRA BERTILSSON

ECO-FLOW HEAT RECOVERY SAVES ENERGY AND HELPS WASHED ITEMS DRY QUICKLY. READ MORE ON PAGE 16

THE HOOD OPENS AND CLOSES AUTOMATICALLY, ELIMINATING THE RISK OF STRAIN INJURIES

THE HOOD IS ANGLED UPWARDS AT THE BACK SO THAT THE STEAM DISCHARGES AT THE BACK OF THE MACHINE RATHER THAN OUT INTO THE ROOM

THE RINSE NOZZLES ON THE STAINLESS STEEL WASHING ARMS ARE CONCAVE TO PREVENT BLOCKAGES

HIGH LEVELS OF HYGIENE WITH AN AUTOMATIC CLEANING PROGRAMME

LARGE WASHING TANK AND EFFICIENT FILTERS KEEP THE WASHING WATER CLEAN FOR LONGER

EASY SERVICING – THE MACHINE CAN BE SERVICED FROM THE FRONT

A kitchen staple

WD-6 and WD-7 are two of the market's best dishwashers for small and medium-sized kitchens.

WD-6 and WD-7 are our reliable hood dishwashing machines and are suitable for small and medium-sized dishwashing rooms. These machines focus on the user, with several technical features that make for a better working environment. With WD-6 and WD-7 you get ease of use, excellent ergonomics, high levels of hygiene, easy servicing and, last but not least, optimum washing results. You can rely on WD-6 and WD-7 365 days a year.

The difference between WD-6 and WD-7 lies in the fact that the latter is larger and used predominantly for larger items and more heavily soiled loads.

AUTOMATIC HYGIENE CONTROL

The control system with built-in HACCP ensures that current hygiene requirements are met. Web-Tool is available as an option for printing out external reports and connecting to a network.

▶ WD-6 AND WD-7 WASHING PROGRAMMES

Programme 1: Total washing time 1.2 min.*

Programme 2: Total washing time 1.7 min.*

Programme 3: Total washing time 3.2 min.*

*Factory setting. The washing time can be adjusted.



WD-7

Save

time, water and energy

> PRM PRE-RINSE MACHINES CAN BE CONNECTED TO BOTH WD-6 AND WD-7.

OPTIMISE DISHWASHING LOGISTICS WITH PRM

Our unique PRM pre-rinse machine pre-rinses items efficiently and replaces manual rinsing. You can save time and water, avoid splashes of water on the floor and improve ergonomics. Reduce repetitive strain injuries by doing away with the monotonous movements associated with using a hand shower.

FEWER CHEMICALS AND IMPROVED ENVIRONMENT

PRM rinses the items from above and below using an unbeatable method that removes even tough food residues such as oil and dressings. This enables you to reduce the washing time and use fewer chemicals. Reducing the amount of chemicals ensures a more gentle wash and also leaves glasses clearer. The water used in the PRM pre-rinse machine is recycled water from the dishwasher. A smart solution that saves both water and energy. Being able to reduce the amount of manual work and at the same time improve the working environment is, of course, equally important.

150 WORK HOURS TO USE ELSEWHERE

With a PRM solution you can put dirty dishes straight into the washing baskets without pre-rinsing with a hand-held spray unit. You don't need to wash items straight away either. PRM's efficient rinse action can handle even dried-on food residues, which means that washing can wait. Unloading and sorting units can help you to achieve an efficient flow of items from the dirty to the clean side, and you can avoid slippery floors caused by splashes of water from a hand-held spray unit.

Save approx. 150 work hours each year in the kitchen, and eliminate 35,000 monotonous movements if washing an average of 100 baskets per day. All this time can be used for other important work in the kitchen.





When diners call, *dishwashing can wait*

A stone's throw from the city centre of Stockholm you find restaurant NAGG, a small, well-run local restaurant providing the local people with French-inspired cuisine using Swedish ingredients. Owner and chef Susanne Törssell is hard at work in the kitchen preparing the evening's menu – spring lamb from Strängnäs with wild garlic from Gotland. Susanne launched NAGG two years ago after managing the Old Orangerie restaurant in the Bergius Botanic Garden in Stockholm.

"There we mostly served lunches, and I knew that my dream was to be able to serve food accompanied by a good wine."

Susanne trained at Grythyttan in Sweden and has also worked at Midsummer House in Cambridge, which has two Michelin stars. Her time there inspired her to take a creative approach to food and wine.

"It was a fantastic learning environment, both in terms of gastronomy and creativity and being organised. Something that can be applied anywhere."

And that's true when you look behind the scenes in Susanne's kitchen and dishwashing area.

A PERFECT SOLUTION IN A TINY SPACE

When Susanne bought the former restaurant the kitchen was tiny, and the absence of work surfaces made the dishwashing area impractical. Despite having limited resources to work with, the kitchen is now larger and more open. The dishwashing room now contains a WD-PRM6 pre-rinse machine and a WD-6 dishwashing machine.

"I didn't think it was possible to create such a practical dishwashing area in a space measuring 2x3 metres. We have work surfaces on both sides of the pre-rinse machine and dishwasher, and it works perfectly," says Susanne.

GOOD SERVICE IS A MUST

"When we are particularly busy during the evening, we often don't have time to do any dishwashing. There are only the two of us working here, and we want to offer our diners



”

“I didn't think it was possible to create such a practical dishwashing area in a space

SUSANNE TÖRSSSELL

the best possible service. We've never even considered employing someone to wash up. Instead, we've focused on having an efficient dishwashing room. Quite simply, the dishes can wait when we've a lot of people in! And that's never a problem because the pre-rinse machine is very effective. We don't need to change the water that often, and we can wash glasses and lightly and heavily soiled items in the same machine without this affecting the washing results," concludes Susanne.

Limited space yet great results



CORNER INSTALLATION 1



CORNER INSTALLATION 2



STRAIGHT INSTALLATION

One litre of water with **DUPLUS**

Is it possible to clean dishes using just one litre of fresh water per washing basket? Yes, it is! Thanks to our patented DUPLUS technology that reduces water consumption to next to nothing.

rinsing phase uses one litre of fresh water at a temperature of 85°C. The rinsing water from the second phase is collected for use in the next washing cycle.

DUPLUS is the ideal choice for anyone aiming for minimal environmental impact from dishwashing.

The secret is to use water from the previous washing cycle during the first rinsing phase. The second

➤ **DUPLUS IS AVAILABLE AS AN OPTION FOR BOTH WD-6 AND WD-7.**

Recover heat with **ECO-FLOW**

Have you ever opened a dishwasher door and got hot steam in your face? Our new undercounter dishwasher WD-4S is now available with ECO-FLOW – a smart heat recovery system which means you can avoid the discomfort of steam in your face. This is particularly important when the machine is located in a bar or is visible to customers.

ECO-FLOW works by using the energy from the steam to heat the water for the next wash. This minimises the amount of steam and reduces the need for ventilation in the room. Drier air is also blown over the items in the machine, meaning they dry far more quickly and effectively. ECO-FLOW has been developed to save energy, as well as to provide an improved working environment.

➤ **ECO-FLOW IS AVAILABLE AS AN OPTION FOR OUR WD-4S, WD-6 AND WD-7 MACHINES.**

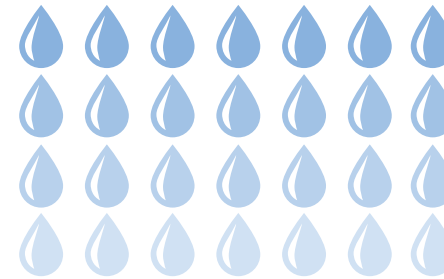

200,000
litres
of water

The annual water savings are impressive. If you choose to add both PRM and DUPLUS to our already water-efficient machines, you can have a dishwasher with the lowest water consumption on the market.

Save!

Here are some examples of what you can save per year if you use a WD-6 or WD-7 with the options PRM and DUPLUS. The savings are per year (350 days).

9,000
kWh ENERGY

Thanks to energy-efficient machines you can significantly reduce your electricity bill.



1 LITRE OF FRESH WATER is all that's needed per wash if you choose DUPLUS for your dishwasher.

200 L
CHEMICALS

Effective rinsing with PRM and the tiny amount of rinsing water used with DUPLUS significantly reduces chemical consumption.

5,200
kg CO₂

Reduce your carbon footprint by up to 5,200 kg per year. This is made possible by dishwashers that require less energy, water and chemicals than the average machine.

Improved kitchen environment!

When you don't need to rinse dishes manually, you avoid wet and slippery floors. A better and safer workplace benefits everyone!

150
HOURS

Pre-rinsing dishes by hand takes time. Use PRM with automatic pre-rinsing and spend the time you save doing something else.

35,000
MONOTONOUS MOVEMENTS

can be eliminated by using PRM instead of pre-rinsing dishes by hand. Reduces the risk of repetitive strain injuries!

What's the best dishwasher for your kitchen?

WD-4S BASIC AND GLASS

Bars, cafés and preschools



WD-4S

The WD-4S is an effective and reliable undercounter dishwasher. The minimal consumption of water and chemicals limits its impact on the environment without compromising the end result. The ECO-FLOW heat recovery system (option) reduces the steam discharge and the need for ventilation in the room, while further reducing energy consumption.

ECO-FLOW
Smart
environmental
choice

- High-quality Swedish design
- Smart touch display in tempered glass
- Good hygiene levels with the door in ventilation mode
- Quick wash with 50 baskets/hour
- Silent operation for a good working environment
- Three specific glass washing programmes (the glass model)
- Easy to change water (at the push of a button)

WD-6 and WD-6 DUPLUS

Restaurants with 50-300 diners/day



WD-6

If you want the best, a high-quality dishwasher that makes work easier for your employees, this is the obvious choice. Ease of use, a good working environment, high levels of hygiene, easy servicing and optimum washing results make the WD-6 one of the best dishwashers on the market. The machine also has a number of programmes that can be individually adapted, allowing it to meet all the different washing requirements that may arise in a kitchen.

- Ease of use – with Auto-Start
- A good working environment – with the unique hood concept
- High levels of hygiene – with an automatic cleaning programme
- Hygiene control – a control system with integrated HACCP
- Easy servicing – the machine can normally be serviced from the front
- Excellent washing results – with self-draining washing arms



WD-6 DUPLUS

Wexiödisk is the first company in the world to introduce a double final rinse for hood dishwashing machines. The technology, which is patented, means that the rinsing process uses considerably less fresh water than traditional final rinse systems. Machines with DUPLUS technology use just 1 litre of fresh water per washing cycle – a tiny amount, yet still produce perfect washing results.

DUPLUS
Smart
environmental
choice

- Double final rinse with DUPLUS technology – improved rinsing results with minimal fresh water, thanks to an extra rinsing phase
- Efficient with low operating costs – the DUPLUS technology helps to reduce consumption of fresh water, chemicals and electricity
- Fantastic cost savings – if osmosis water has to be used
- A good working environment – with the unique hood concept

WD-7 and WD-7 DUPLUS

Restaurants with 50-300 diners/day



COMBI-DISHWASHING MACHINE WD-7 AND WD-7 DUPLUS

The feed clearance height of 505 mm and the internal width of 605 mm enables not only plates, glassware and cutlery to be cleaned, but also heavily soiled items such as baking trays, bread baskets, large bowls, Gastronorm containers, etc.

The robust and ingenious design means the machine can cope with today's demanding kitchen environments. The

unique hood concept and the new Auto-Start option have improved the ergonomics of the machine and significantly simplified the washing process. Simply slide in the basket, the hood closes automatically and the machine starts. When the washing programme has finished, the hood opens automatically and the steam discharges at the back of the machine. You can quickly and easily reset the machine to wash heavily soiled loads, which increases the rinse pressure. This function, in combination with three different programme options, meets the varying needs of any kitchen.

- Functional design
- Two machines in one – for normal and heavily soiled items.
- Even better washing results
- Maximum hygiene
- Ergonomic and efficient
- Double final rinse with DUPLUS technology – improved rinsing results with minimal fresh water, thanks to an extra rinsing phase
- Efficient with low operating costs – the DUPLUS technology helps to reduce consumption of fresh water, chemicals and electricity
- Fantastic cost savings – if osmosis water has to be used

WD-PRM6 and WD-PRM7

Restaurants with 100-400 diners/day



PRE-RINSE MACHINE WD-PRM6 AND WD-PRM7

Wexiödisk WD-PRM6/7 has been developed to replace the manual hand shower in dishwashing rooms. Huge savings can be achieved in water, energy, chemicals and effort. Can also be added to your existing WD-6 or WD-7 hood dishwashing machine.

PRM
Smart
environmental
choice

With DUPLUS you can achieve the following savings:

- 200,000 litres of water
- 9,800 kWh energy when using warm or hot water
- The environment benefits, with 5,200 kg less CO₂ being produced
- 150 work hours
- Dishwashing staff are spared 35,000 repetitive hand movements associated with manual pre-rinsing that can cause occupational injuries
- Less detergent is used
- Improved working environment with less water on the floor
- Dishwashers have a larger capacity
- Reduction in daily water changes



WD-4S BASIC / GLASS

UNDERCOUNTER DISHWASHER

FEATURES

- The WD-4S can wash up to 50 baskets per hour. This amounts to 1,000 glasses, 900 plates or 450 trays - hour after hour after hour.
- The clean design means that the washing chamber is larger and can even accommodate trays up to a size of 530 x 330 mm and 1/1 canteens with accessories.
- A simple push of a button allows you to easily change the water so you can switch between washing soiled plates and washing glasses and trays. The two functions in the same machine save both space and time.
- The low noise levels when the machine is in operation results in a good working environment.
- The door can be placed in a space-saving hygienic position, which prevents the growth of bacteria when the machine is not in use.
- The stainless steel wash arms have individually positioned nozzles. This allows coverage and cleaning of every millimetre of the dishware.
- An inbuilt drain pump ensures that all of the water is emptied regardless of the machine's position.
- Automatic control of the water temperature and quantity, as well as automatic cleaning, ensures a high standard of hygiene.
- Inbuilt dosing for both detergent and drying agents simplifies operation. No need for bulky dosing equipment next to the machine.
- Back flow protection prevents the back-flow of dirty water into the mains water system.

OPTIONS

- ECO-FLOW condensing unit with heat recovery by the exhausted steam. (cold water connection is required) 6,9 kW booster heater is recommended.

EXTRA EQUIPMENT

- Bottom frame with guide rails for 3 baskets (201.0556)
- Bottom frame with guide rails for 3 baskets, lockable cabinet for detergent and drying agent for (201.0557)
- Integrated under the bench set, on right side (201.0550H)
- Integrated under the bench set, on left side (201.0550V)



- Glass basket (201.0558)

TECHNICAL DATA BASIC & GLASS MODEL	WD-4S
Wash pump (kW)	0,75
Booster heater (kW) (400V / 230V)	4,2/2,8
Tank heater (kW)	1,4
Drain pump (kW)	0,04
Booster poump (kW) *	0,37
Tank volume (litres)	20
Heat recovery fan (kW) **	0,01
Weight, machine in operation (kg)	85
Enclosure class (IP)	44

* Only in combination with breaktank

** Option on some markets

CAPACITY AND OPERATING DATA	WD-4S
Capacity, maximum number of baskets per hour	50**
Basket size (mm)	500x500
Total wash time BASIC programme 1 (min.) **	1,2
Total wash time BASIC programme 2 (min.) **	2,4
Total wash time BASIC programme 3 (min.) **	4,2
Total wash time GLASS programme 1 (min.) **	1,2
Total wash time GLASS programme 2 (min.) **	1,2
Total wash time GLASS programme 3 (min.) **	2,2
Water consumption rinse/programme (litres)	2,4
Sound level (dB(A))	61
Maximum surface temperature at a room temperature of 20°C	35

* Hot water connection 55 - 70 °C. With cold water connection or condensing unit the capacity is lowered.

** Factory setting. The wash time is adjustable.

CONNECTION, MACHINE	WD-4S
Total connected power (kW) (400V 3N~) *	4,95/7,65*
Total connected power (kW) (230V 1N~)	3,55
Main fuse (400V 3N~ (A)) **	10/16**
Main fuse (230V 3N~ (A))	16
Connection cable, area 400V 3N~ (L1-L3, N, PE) Cu (mm ²) ***	2,5

* Cold water connection

** Other voltage on request

*** 2 meter cable is included

Wexiödisk

We reserve the right to make changes to the technical data.

WATER, DRAIN AND VENTILATION CONNECTIONS	WD-4S
Water quality, hardness (°dH)	2-7
Hot water connection (55- 70 °C) (external thread)	R ¾"
Cold water connection (5-12 °C) (external thread) *	R ¾"
Drain connection, hose 2 meter, of which 1.3 meters outside the machine (ø mm)	22
Water capacity, pressure (kPa)	20
Water capacity, flow (litres/min)	5
Floor drain (litres/sec.)	1
Heat load to room (total, sensible, latent) (kW)	1,7 / 1,2 / 0,5

* Option on some markets

SIZE AND WEIGHT FOR TRANSPORTATION	WD-4S
Size (LxWxH) (mm) incl. packaging	700x760x1000
Weight of machine (kg), including packaging	85

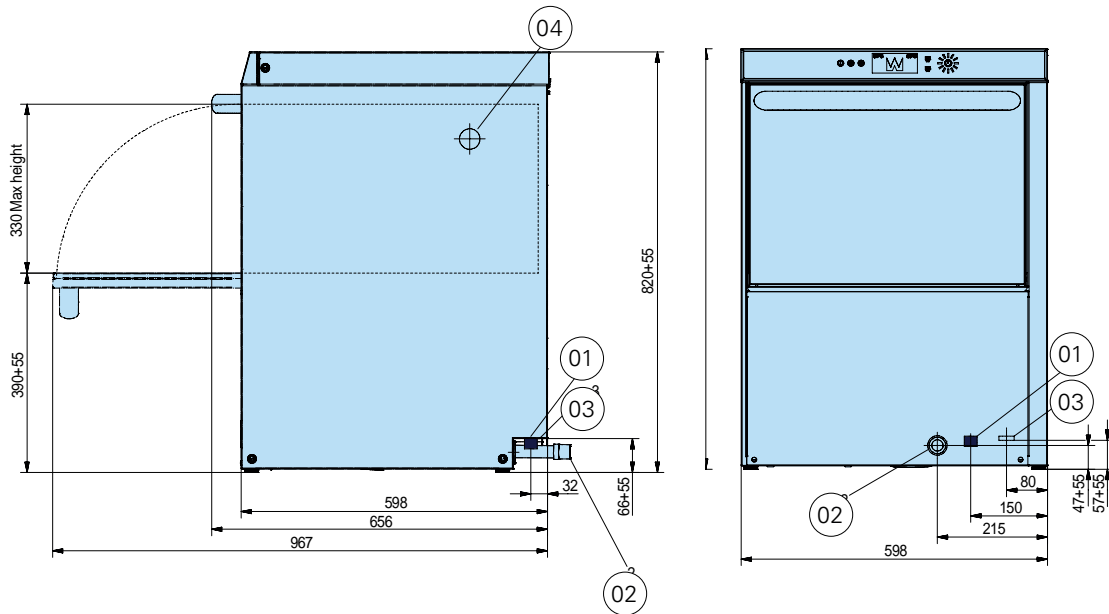

- 01. Water connection, external thread, R3/4"
- 02. Drain connection, PP pipe, Ø 22mm, length 2m
- 03. Electrical connection cable, length 2m
- 04. Non-return valve

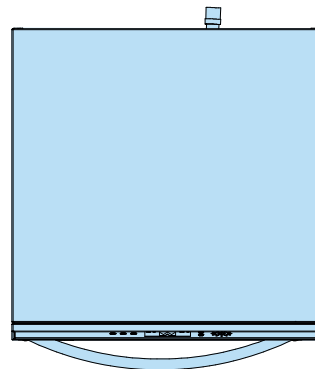
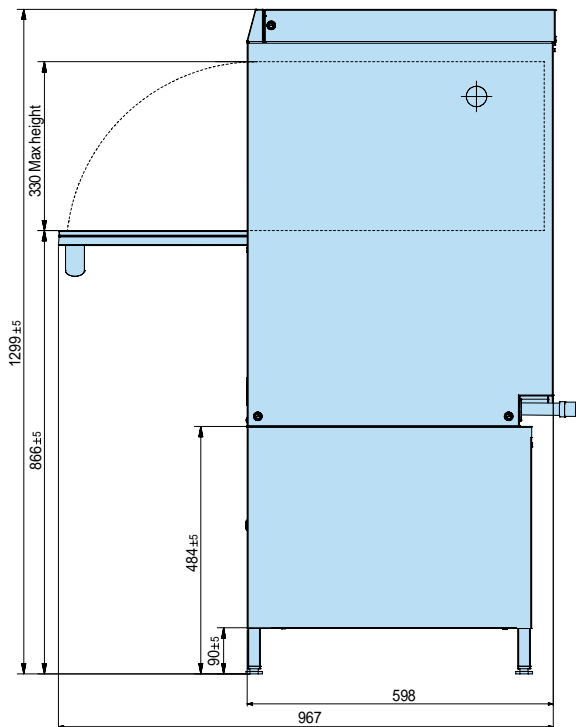

Wexiödisk

The Hood Type Concept



The new green Hood Type Concept saves more than just water...

Wexiödisk introduces an innovative and environmentally friendly solution for your dishwashing operation. Today most people focus on final rinse water consumption, not taking into consideration the huge amount of both fresh water consumed by manual pre washing and energy going into the drain every day.

Greener than ever! The pre-rinse machine PRM, condensing unit and state of the art heat exchanger are three concrete examples, which contributes to less impact on the environment. Complementary to the already well-known features of Wexiödisk hood type machines such as automatic hood lift with Auto-Start and reliability among others makes this concept unique.

PRM GREEN

“Not only does the PRM give 20 times better result than traditional overhead spray units, it also reduces the running cost by totally eliminating manual pre-rinsing”

Forget the extra manual labor involved and the additional use, or rather waste, of clean water with the PRM Green. No longer will you need an overhead spray unit to pre-rinse soiled dishware. By combining the optional automatic hood with Auto-start you simply push your dish rack into the pre-rinse unit. The hood will close and begin the cycle. After 30 seconds and 200 liters of recycled pre-rinse water the hood opens automatically and the rack can be moved into the main dishwasher. And, for versatility, if your soil load is light, the PRM can simply be by-passed. It does not operate if a rack is not detected in the chamber.

PRM GREEN CASE STUDY

Assuming you wash 150 racks per day, then each year:

- *you save around 200,000 litres of water*
- *you save 8000 kWh energy when using warm or hot water*
- *you save the environment from 4100 kg CO₂*
- *you save 85 hours of labour*
- *Spare your staff from 55000 repetitive manual pre-rinsing movements.*
- *you use less detergent*
- *your work environment is improved with less water splashing*
- *you achieve a higher capacity out of a single tank machine*
- *reduce the need of water changes during the day*



Water saving *for real*

The PRM Green washes for 30 seconds with 200 liters of hot recycled detergent water, both from above as well as underneath, which is impossible to achieve manually. There is significant water saving by using overflow water from the dishwasher in the pre-rinse unit. Not only does the PRM give 20 times better result than traditional overhead spray units, it also reduces the running cost by totally eliminating manual pre-rinsing. In this way operators can focus on sorting and arranging dirty dishes more efficiently.

Other benefits

By using the PRM the total contact time is extended. This increases the total capacity for the hood type machine since shorter washing programs can be used. The working environment is improved by replacing the repetitive manual pre-rinsing movement that can lead to occupational injuries. Additionally, your working environment is improved by less water splashing.

Heat recovery system GREEN

Our environmental solutions for the WD-6 and WD-7 reduce the impact on the environment and lower your running costs significantly. Using the heat exchanger heat is recovered from the waste water energy, transferred back by heating the incoming cold water. Even greater savings can be achieved in combination with the steam condensing unit.

We have used heat recovery steam condensers on large dishwashers with efficient result for many years. The "green" condensing unit gives a significantly improved working environment and at the same time saves energy. At the end of the cycle, when the hood is lifted slightly, an inbuilt extraction fan removes excess steam from the machine. This hot moist air is passed through a condenser, pre-heating incoming cold water used in the final rinse. At the same time cool air is blown in the dish room for a better climate.

CUSTOMER BENEFITS

Heat exchanger

- *State of the art solution with minimum loss to the drain.*
- *Saves approximately 34% energy or 0.11 kWh per basket.*
- *no need for hot water connection*

Steam condensing unit

- *improves the room temperature and working environment*
- *reduces the need for external ventilation and ideal for areas with poor external extraction.*
- *saves approximately 9% of energy or in combination with heat exchanger 0.13 kWh per rack*
- *Improves the drying result and easy to clean*

The heat exchanger cannot be used if the hood type machine is connected to a PRM.

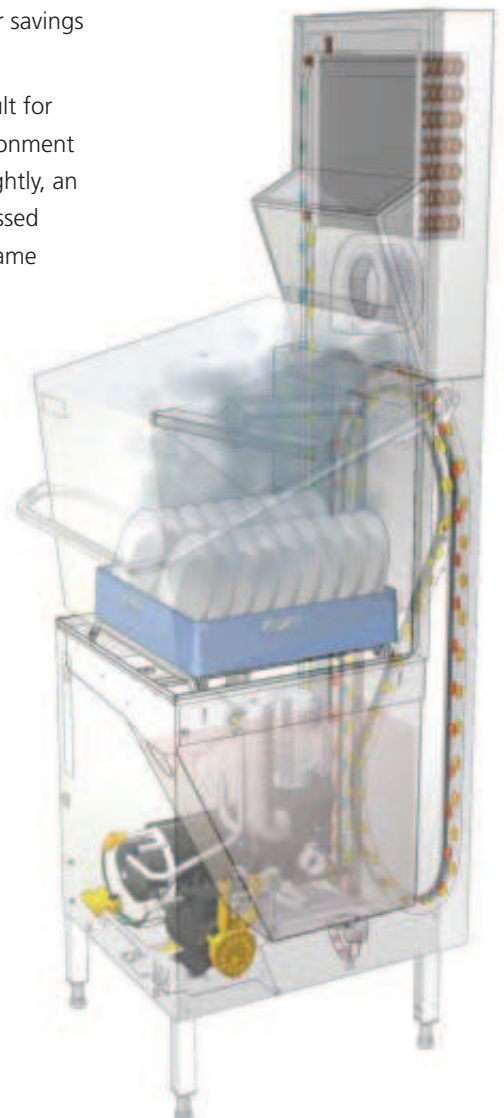

Technical data WD-PRM6 / WD-PRM7

Technical data	WD-PRM6	WD-PRM7
Article number	204-006	204-007
Wash pump (kW)	0,9	0,9
Tank volume (litres)	45	45
Weight, machine in operation (kg)	130	150
Degree of protection (IP)	45	45
Capacity and operation data	WD-PRM6	WD-PRM7
Total time pre-rinse (min)	0,5	0,5
Capacity, max (baskets/h)	120	120
Sound level* (dB(A))	64	64
Connection, machine	WD-PRM6	WD-PRM7
Total connected power (kW)	0,9	0,9
Main fuse 400V 3N~ (A)**	10	10
Max.conn.area 400V 3N~ (L1-L3,N,PE) Cu (mm ²)***	2,5	2,5
Connection water, drain and ventilation	WD-PRM6	WD-PRM7
Drain connection, PP pipe (ø mm)	50	50
Water capacity cold water hood lift, pressure (kPa)****	300	300
Water capacity cold water hood lift, flow (l/min)****	2	2
Floor drain, capacity (litres/sec)	3	3
Ventilation, machine (m ³ /h)	200	200
Size and weight for transportation	WD-PRM6	WD-PRM7
Size ***** LxWxH (mm)	765x710x1560	765x805x1650
Weight ***** (kg)	100	105
Extra equipment	WD-PRM6	WD-PRM7
Connection kit between PRM and WD-6/WD-7, connection plate L= 140 mm. (Not for connection to the front plate.)	204,0660	204,0660
Connection kit between PRM and WD-6/WD-7, connection plate L= 300 mm. (For straight and corner installation.)	204,0665	204,0665
Connection kit with cabinet for chemicals, between PRM and WD-6/WD-7, connection plate L= 300 mm. (Not for connection to the front plate.)	204,0667	204,0667

* Measured 1 metre from the machine

** Other voltages on request

*** Cabel 2m H07RN-F included

**** Option. If pressure / flow is lower the machine should be equipped with a booster pump.

***** Packaging included

The total amount of saved water, energy and labour depends on local conditions.

Dimensional drawings Condensing unit / Heat exchanger

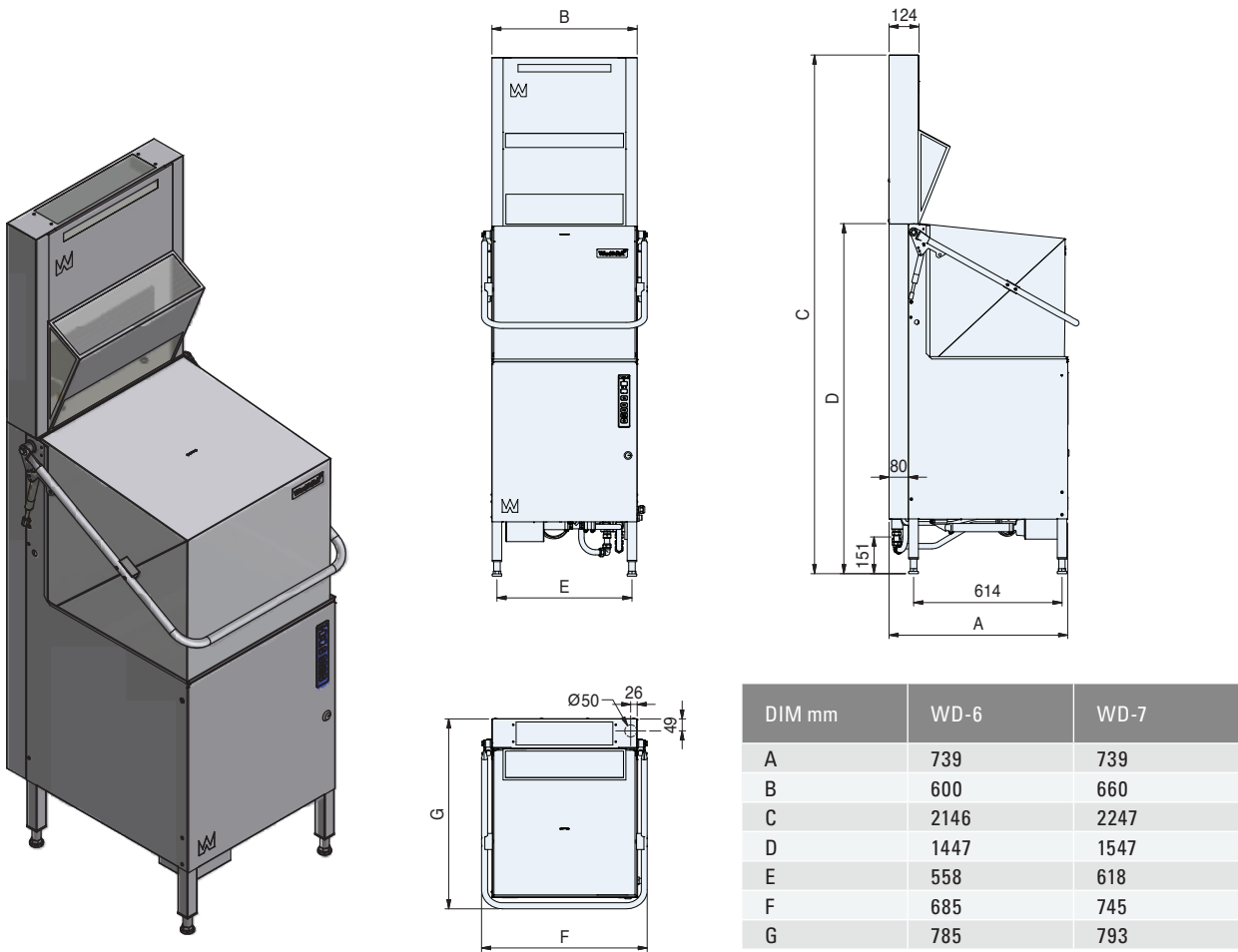

Technical data Condensing unit

Technical data	WD-6	WD-7
Article number	203-0640	203-0740
Fan, heat recovery (kW)	0,13	0,13
Weight accessory (kg)*	26	28

Technical data Heat exchanger

Technical data	WD-6	WD-7
Article number	203-0650	203-0750
Pump (kW)	0,17	0,17
Weight accessory (kg)*	25	26

* Packaging included

The total amount of saved energy depends on local conditions.

Layout WD-6 / WD-7 in combination with
WD-PRM6 / WD-PRM7

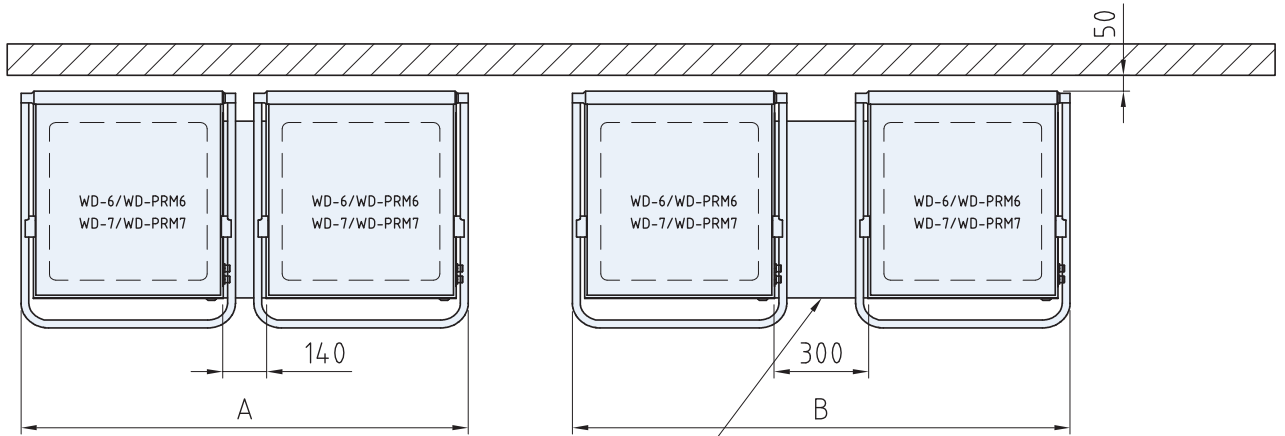

With or without cabinet

DIM mm	WD-6	WD-7
A	1418	1538
B	1578	1698
C	1594	1654

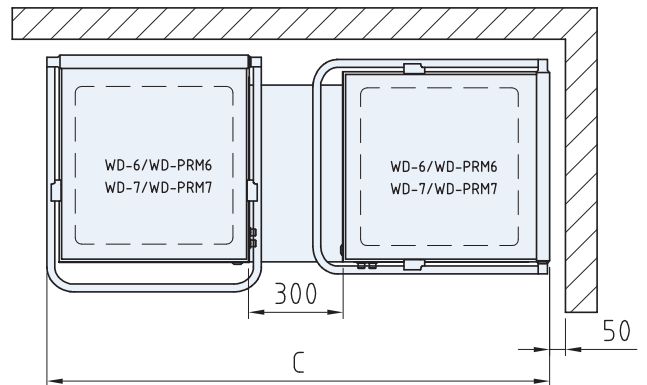

BECAUSE WE DO CARE

Telephone: +46 470 77 12 00
Fax: +46 470 237 52
Address: Mårdvägen 4
SE-352 45 Växjö
Sweden
E-mail: wexiodisk@wexiodisk.com

Wexiödisk 

www.wexiodisk.com



WD-6

HOOD TYPE DISHWASHER

FEATURES

- Robust and reliable design in stainless steel with components that guarantee a durable and reliable operation for many years
- The machine has an energy saving heat and sound insulating double-skinned hood.
- A good working environment with the unique hood concept
- High levels of hygiene with an automatic cleaning programme and guaranteed rinse temperature by thermal stop system
- Self-drained wash pump
- Large deep tank to protect against foaming
- Easy servicing - the machine is serviced from the front
- Hygiene control – control system with integrated HACCP
- Excellent wash results – with selfdraining washing arms
- Powerful washing pressure with anti-blocking nozzles
- Individual adjustable wash- and rinse times as well as temperatures for each programme
- Inbuilt dosing pump for fine dosage of rinse aid

OPTIONS

- Automatic hood
- Autostart for automatic hood
- 230V/1/50Hz
- 230V/3/50Hz
- Marine version
- Detergent pump for liquid detergent
- Panel on left side
- Lockable cabinet for chemicals (not in comb. with break tank or panel on left side)
- Booster heater for cold water connection.
- Drain pump
- Break tank with booster pump (to be used when no external resuction protection is mounted)
- Booster pump connected with WD-PRM6 equipped with automatic hood (In combination with break tank)
- ECO-FLOW condensing unit with heat recovery by the exhausted steam. (cold water connection is required)
- Heat exchanger with heat recovery by the drain water. Not in combination with PRM. (cold water connection is required)
- WEB Tool - For external HACCP documentation



EXTRA EQUIPMENT

- Steam hood with suction connection
- Shelf for chemical storage
- Sideboard (560 x 560 mm)

TECHNICAL DATA	WD-6
Wash pump (kW)	0.9
Booster heater (kW)	9/12*
Heater tank (kW)	1.8
Tank volume (litres)	50
Weight, machine in operation (kg)	160
Degree of protection (IP)	45

* 12 kW booster heater is optional.

CAPACITY AND OPERATION DATA	WD-6
Total time/wash program 1 (min)	1.2**
Total time/wash program 2 (min)	1.7**
Total time/wash program 3 (min)	3.2**
Capacity, max (baskets/h)	50
Water consumption rinse/program (litres)	2.5-4***
Energy consumption (kWh of connected power)	70-90%
Sound level* (dB(A))	61

* Measured 1 metre from the machine.

** Factory setting. The wash time is adjustable.

*** Applies under ideal conditions. The water consumption depends on local conditions. An exact adjustment is made during installation.

CONNECTION, MACHINE	WD-6
Total connected power (kW)	9.9/12.9*
Main fuse 400V 3N~ (A)**	16/20*
Max connection area 400V 3N~(L1-L3, N, PE) Cu (mm2)***	2.5

* 12 kW booster heater is optional.

** Other voltages on request.

*** Cabel 2.5m H07RN-F included.

Wexiödisk 

CONNECTION WATER, DRAIN AND VENTILATION	WD-6
Water quality, hardness (°dH)	2-7
Hot water connection 55-70°C (external thread)	R 1/2"
Cold water connection 5 - 12 °C* (external thread)	R 1/2"
Drain connection, PP pipe (ø mm)	50
Water capacity, pressure (kPa)	180**
Water capacity, flow (litres/min)	18
Water capacity hood lift, pressure (kPa)	180**
Floor drain, capacity (litres/sec)	3
Heat load to the room (total, sensible, latent) (kW)	2.3 / 1.7 / 0.6

* If colder water than 55° C a 12 kW booster heater is recommended.
 ** If pressure / flow is lower the machine should be equipped with a break tank.

SIZE AND WEIGHT FOR TRANSPORTATION	WD-6
Size LxWxH (mm) *	765x710x1560
Weight (kg) *	115

* Packaging included.

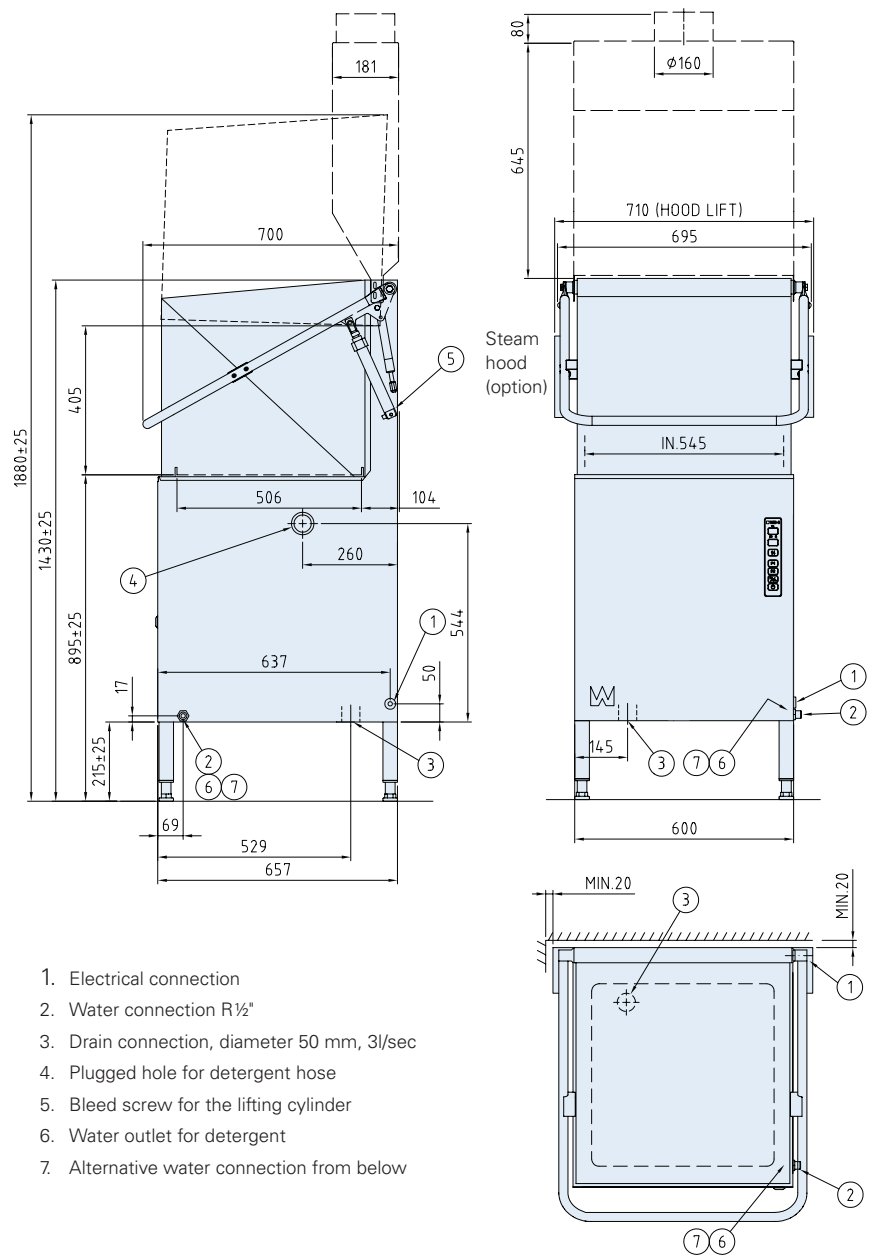

WD-6 with **ECO-FLOW** condensing unit and heat exchanger

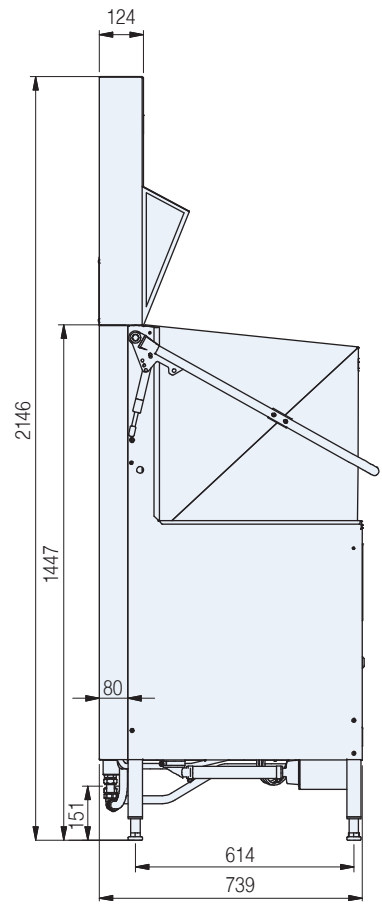

WD-6C

HOOD TYPE DISHWASHER

FEATURES

- Robust and reliable design in stainless steel with components that guarantee a durable and reliable operation for many years
- The machine has an energy saving heat and sound insulating double-skinned hood.
- A good working environment with the unique hood concept
- Self-drained wash pump
- Large deep tank to protect against foaming
- Wash pump intake with strainer
- Easy servicing - the machine is serviced from the front
- Excellent wash results – with selfdraining washing arms
- Powerful washing pressure with anti-blocking nozzles
- Dosing pump for fine dosage of rinse aid

OPTIONS

- 230V/3/50Hz
- Detergent dispenser for liquid detergent
- Drain pump

EXTRA EQUIPMENT

- Connection pipe with non-return valve and vacuum valve
- Steam hood with suction connection
- Shelf for chemical storage
- Sideboard (560 x 560 mm)



TECHNICAL DATA	WD-6C
Wash pump (kW)	0.9
Booster heater (kW)	9
Heater tank (kW)	1.8
Tank volume (litres)	50
Weight, machine in operation (kg)	160
Degree of protection (IP)	45

CAPACITY AND OPERATION DATA	WD-6C
Total time/wash program 1 (min)	1.5
Capacity, max (baskets/h)	35
Water consumption rinse/program (litres)	4
Energy consumption (kWh of connected power)	70-90%
Sound level* (dB(A))	61

* Measured 1 metre from the machine.

CONNECTION, MACHINE	WD-6C
Total connected power (kW)	9.9
Main fuse 400V 3N~ (A) *	16
Max connection area 400V 3N~ (L1-L3, N, PE) Cu (mm2)**	2.5

* Other voltages on request.

** Cabel 2.5m H07RN-F included.

CONNECTION WATER, DRAIN AND VENTILATION	WD-6C
Water quality, hardness (°dH)	2-7
Hot water connection 55-70°C (external thread)	R ½"
Drain connection, PP pipe (ø mm)	50
Water capacity, pressure (kPa)	180**
Water capacity, flow (litres/min)	18
Floor drain, capacity (litres/sec)	3
Heat load to the room (total, sensible, latent) (kW)	2.3 / 1.7 / 0.6

** If pressure / flow is lower the machine should be equipped with a break tank.

SIZE AND WEIGHT FOR TRANSPORTATION	WD-6C
Size LxWxH (mm) *	765x710x1560
Weight (kg) *	115

* Packaging included.

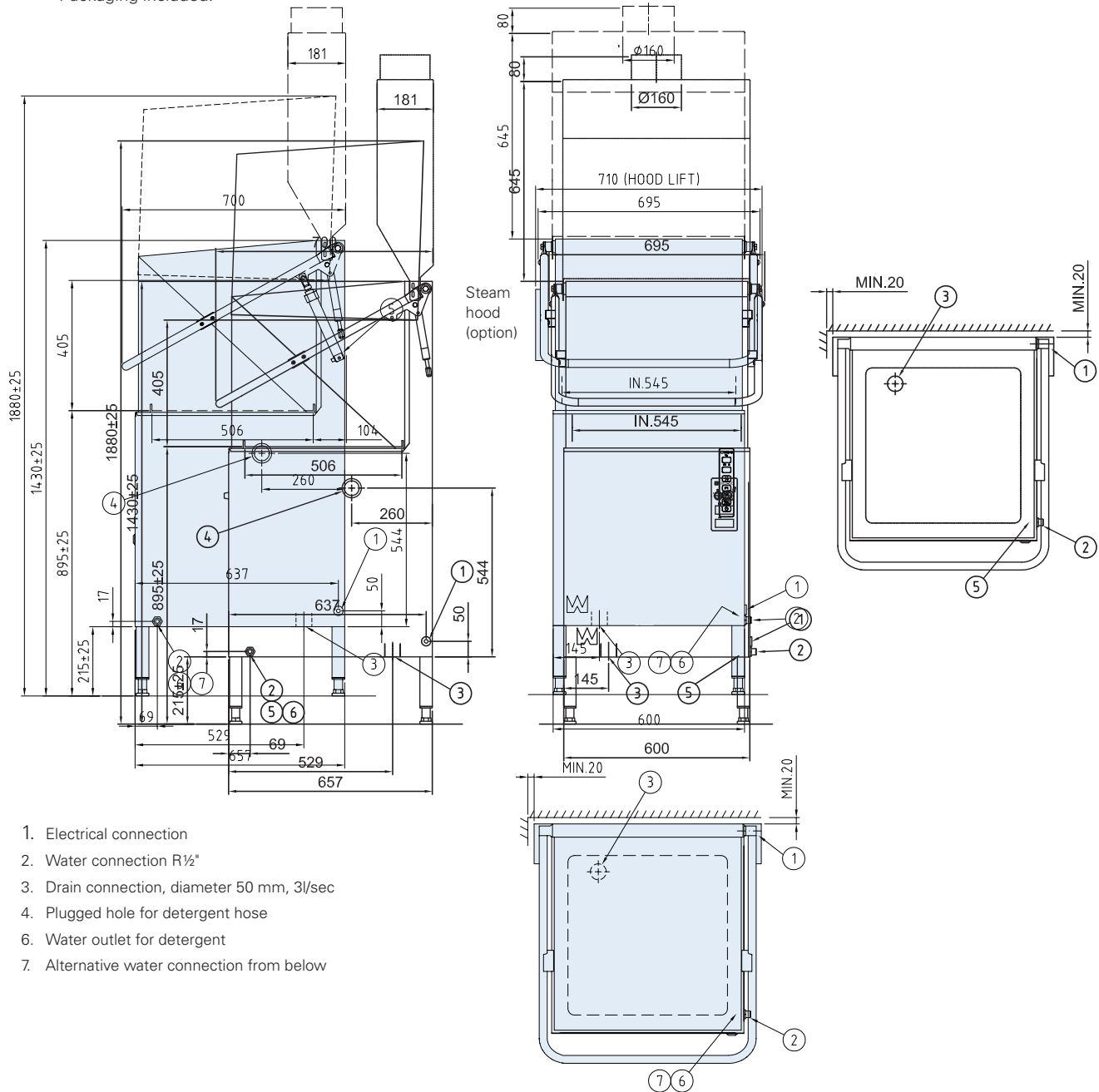

1. Electrical connection
2. Water connection R½"
3. Drain connection, diameter 50 mm, 3l/sec
4. Plugged hole for detergent hose
6. Water outlet for detergent
7. Alternative water connection from below

We reserve the right to change technical data.

Wexiödisk



WD-7

HOOD TYPE DISHWASHER

FEATURES

- Unique and flexible washing system. The machines water pressure can be reset quickly and easily between normal and heavily soiled settings
- Robust and reliable design in stainless steel with components that guarantee a durable and reliable operation for many years
- The machine has an energy saving heat and sound insulating double-skinned hood
- A good working environment with the unique hood concept
- High levels of hygiene with an automatic cleaning programme and guaranteed rinse temperature by thermal stop system
- Self-drained wash pump
- Large deep tank to protect against foaming
- Easy servicing - the machine is serviced from the front
- Hygiene control – control system with integrated HACCP
- Excellent wash results – with selfdraining washing arms
- Powerful washing pressure with anti-blocking nozzles
- Individual adjustable wash- and rinse times as well as temperatures for each programme
- Inbuilt dosing pump for fine dosage of rinse aid

OPTIONS

- Automatic hood
- Autostart for automatic hood
- 230V/1/50Hz
- 230V/3/50Hz
- Marine version
- Detergent pump for liquid detergent
- Panel on left side
- Lockable cabinet for chemicals (not in comb. with break tank or panel on left side)
- Booster heater for cold water connection
- Drain pump
- Break tank with booster pump (to be used when no external resuction protection is mounted)
- Booster pump connected with WD-PRM7 equipped with automatic hood (In combination with break tank)
- ECO-FLOW condensing unit with heat recovery by the exhausted steam. (cold water connection is required)
- Heat exchanger with heat recovery by the drain water. Not in combination with PRM. (cold water connection is required)



- WEB Tool - For external HACCP documentation

EXTRA EQUIPMENT

- Connection pipe with non-return valve and vacuum valve
- Steam hood with suction connection
- Shelf for chemical storage
- Sideboard (560 x 560 mm)
- Rack for 8 pcs baking plates
- Special rack for containers

TECHNICAL DATA	WD-7
Wash pump (kW)	1,1
Booster heater (kW)	9/12*
Tank heater (kW)	1,8
Tank volume (litres)	50
Weight, machine in operation (kg)	170
Enclosure class (IP)	45

* 12 kW booster heater is optional.

CAPACITY AND OPERATING DATA	WD-7
Total washing time P1 (min)	1,2**
Total washing time P2 (min)	1,7**
Total washing time P3 (min)	3,2**
Max. capacity, baskets/hour (no.)	50
Water consumption rinsing/programme (litres)	2,5-4***
Energy consumption (% of connected power)	70-90%
Sound level (dB(A))*	63/65

* Measured 1 metre from the side of the machine.

** Factory setting. The washing time can be adjusted.

*** Applies under ideal conditions. The water consumption depends on local conditions. An exact adjustment is made during installation.

CONNECTION, MACHINE	WD-7
Total connected power (kW)	10,1/13,1*
Main fuse 400V 3N~ (A) **	16/20*
Max. connection area 400-415V 3N~ (L1-L3,N,PE) Cu (mm2) ***	2,5

* With 12 kW booster heater (optional).

** Other voltage on request.

*** Cable 3 m H07RN-F is included.

Wexiödisk

WATER, DRAIN AND VENTILATION CONNECTIONS	WD-7
Water quality, hardness (°dH)	2 - 7
Water connection 5-70°C (external thread)*	R ½"
Drain connection, PP pipe (ø mm.)	50
Water capacity, min/max pressure (kPa)	180**
Water capacity, flow (litres/min)	18
Water capacity hood lift, pressure (kPa)	300**
Floor drain, capacity (litres/sec)	3
Heat load to the room (total, sensible, latent) (kW)	2,3/1,7/0,6

* If colder water than 55°C a 12 kW booster heater is recommended.

** If pressure/flow is lower the machine should be equipped with a break tank.

SIZE AND WEIGHT FOR TRANSPORTATION	WD-7
Size, LxWxH (mm.) *	765x805x1650
Weight (kg) *	125

* Packaging included

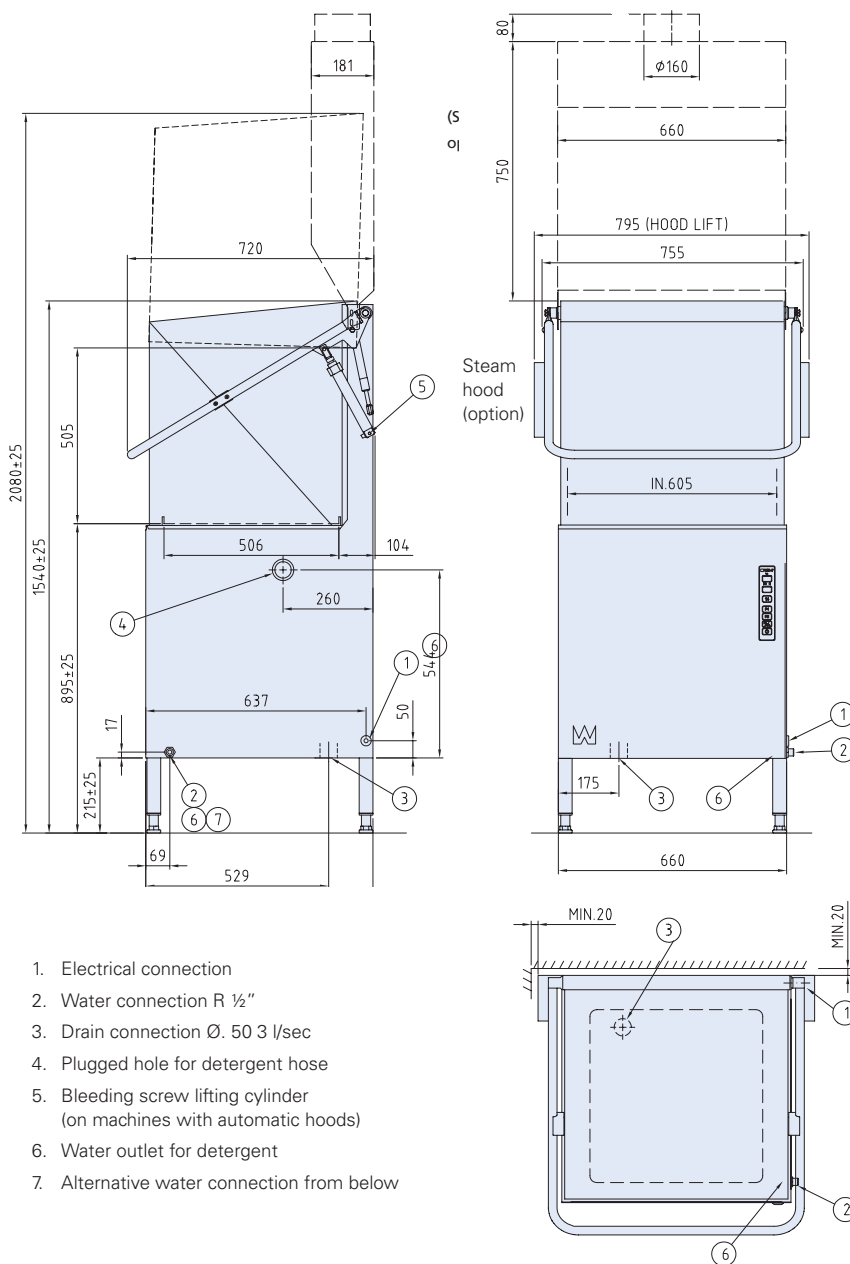

1. Electrical connection
2. Water connection R ½"
3. Drain connection Ø. 50 3 l/sec
4. Plugged hole for detergent hose
5. Bleeding screw lifting cylinder (on machines with automatic hoods)
6. Water outlet for detergent
7. Alternative water connection from below

We reserve the right to change technical data.

WD-7 with ECO-FLOW condensing unit and heat exchanger

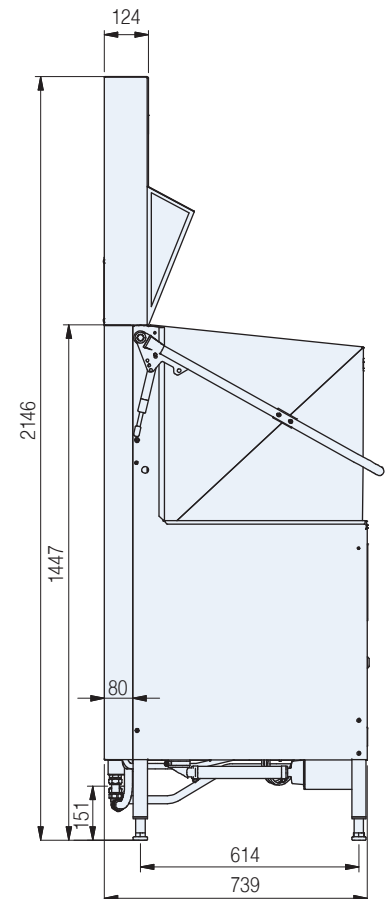

Wexiödisk

WD-7 DUPLUS

HOOD TYPE DISHWASHER

FEATURES

- Double final rinse with DUPLUS technology – Improved rinsing results using less fresh water
- High efficiency with low operating costs – DUPLUS technology reduces the consumption of fresh water, chemicals and electricity
- Particularly large cost savings – if osmosis water has to be used
- Unique and flexible washing system. The machines water pressure can be reset quickly and easily between normal and heavily soiled settings
- Robust and reliable design in stainless steel with components that guarantee a durable and reliable operation for many years
- The machine has an energy saving heat and sound insulating double-skinned hood
- A good working environment with the unique hood concept
- High levels of hygiene with an automatic cleaning programme and guaranteed rinse temperature by thermal stop system
- Self-drained wash pump
- Large deep tank to protect against foaming
- Easy servicing - the machine is serviced from the front
- Hygiene control – control system with integrated HACCP
- Excellent wash results – with selfdraining washing arms
- Powerful washing pressure with anti-blocking nozzles
- Individual adjustable wash- and rinse times as well as temperatures for each programme
- Inbuilt dosing pump for fine dosage of rinse aid
- Break tank with booster pump



OPTIONS

- Automatic hood
- Autostart for automatic hood
- 230V/3/50Hz
- Marine version
- Detergent pump for liquid detergent
- Panel on left side
- Drain pump
- Booster pump connected with WD-PRM7 equipped with automatic hood (In combination with break tank)
- ECO-FLOW condensing unit with heat recovery by the exhausted steam. (cold water connection is required)
- WEB Tool - For external HACCP documentation

EXTRA EQUIPMENT

- Steam hood with suction connection
- Shelf for chemical storage
- Sideboard (560 x 560 mm)

TECHNICAL DATA	WD-7 DUPLUS
Wash pump (kW)	1.1
Pump, recirculated rinse (kW)	0.67
Pump, final rinse (kW)	0.67
Booster heater (kW)	9
Tank heater (kW)	5.4
Tank volume, chemical wash tank (liter)	45
Tank volume, recirculated rinse (liter)	5.5
Weight, machine in operation (kg)	195
Enclosure class (IP)	45

CAPACITY AND OPERATING DATA	WD-7 DUPLUS
Total washing time P1 (min) *	1.2
Total washing time P2 (min) *	1.8
Total washing time P3 (min) *	3.3
Max. capacity, baskets/hour (no.)	50
Water consumption rinsing/programme (liter) **	1.0 - 1.5
Energy consumption (% of connected power)	30 - 50%
Sound level (dB(A))***	63

* Factory setting. The washing time can be adjusted.

** In combination with WD-PRM7 the water consumption can be lowered further.

*** Measured 1 metre from the side of the machine.

CONNECTION, MACHINE	WD-7 DUPLUS
Total connected power (kW)	10.1
Main fuse 400 3N~ (A) *	16
Max. connection area 400V 3N~ (L1-L3,N,PE) Cu (mm ²) **	2.5

* Other voltage on request.

** Cable 3 m H07RN-F is included.

Wexiödisk

WATER, DRAIN AND VENTILATION CONNECTIONS	WD-7 DUPLUS
Water quality, hardness (°dH)	2 - 7
Water connection 5-70°C (external thread)*	R ½"
Drain connection, PP pipe (ø mm.)	50
Water capacity, pressure (kPa)	20
Water capacity, flow (litres/min)	5
Floor drain, capacity (litres/sec)	3
Heat load to the room (total, sensible, latent) (kW)	1.7 / 1.2 / 0.5

* When using cold water <55°C the filling time is longer.

SIZE AND WEIGHT FOR TRANSPORTATION	WD-7 DUPLUS
Size, LxWxH (mm.)*	765x805x1650
Weight (kg)*	160

* Packaging included

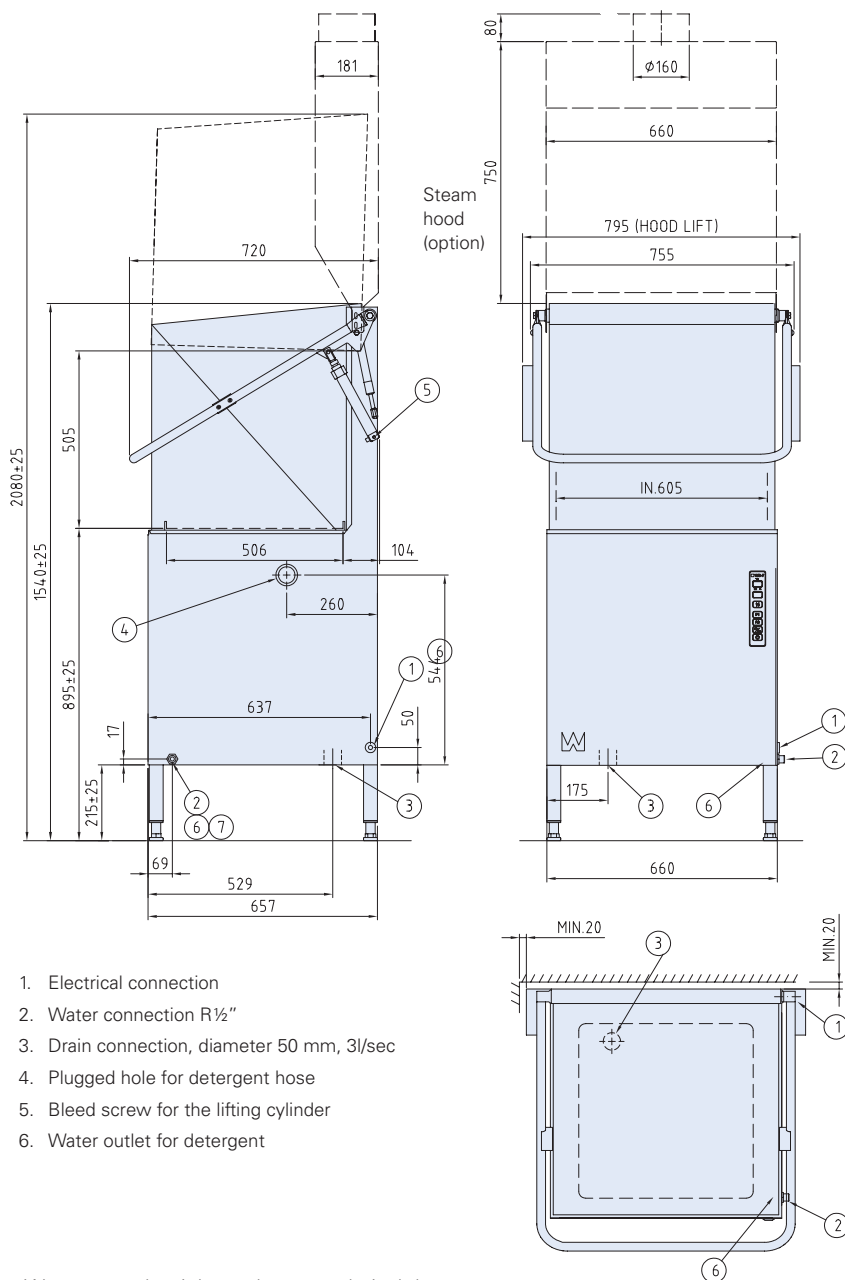

1. Electrical connection
2. Water connection R ½"
3. Drain connection, diameter 50 mm, 3l/sec
4. Plugged hole for detergent hose
5. Bleed screw for the lifting cylinder
6. Water outlet for detergent

We reserve the right to change technical data.

WD-7 Duplus with **ECO-FLOW** condensing unit and heat exchanger

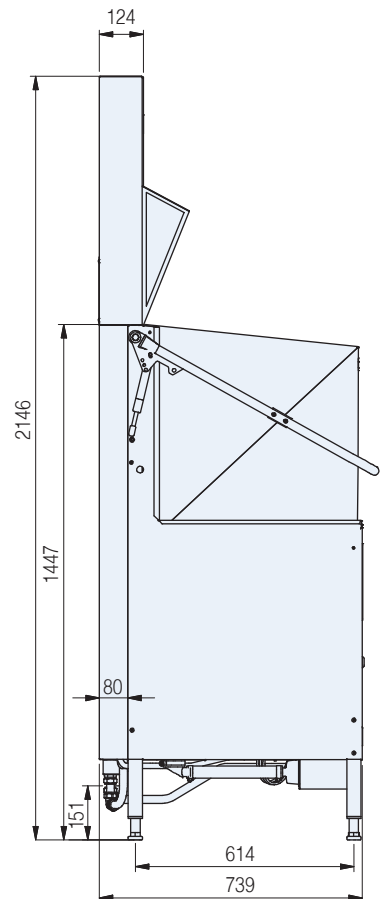

Wexiödisk

WD-12

COMBI-DISHWASHER

FEATURES

- Flexible combi-dishwasher with large dishwashing area
- The machine has adjustable washing pressure for normal and heavily soiled loads
- Powerful and effective – extraordinary washing results with dual pumps and rinsing system
- Robust and reliable design in stainless steel with components that guarantee a durable and reliable operation for many years
- The machine has an energy saving heat and sound insulating double-skinned hood.
- A good working environment with the unique hood concept
- Automatic hood
- High levels of hygiene with an automatic cleaning programme and guaranteed rinse temperature by thermal stop system
- Self-drained wash pump
- Large deep tank to protect against foaming
- Easy servicing - the machine is serviced from the front
- Hygiene control – control system with integrated HACCP
- Excellent wash results – with selfdraining washing arms
- Powerful washing pressure with anti-blocking nozzles



- Individual adjustable wash- and rinse times as well as temperatures for each programme
- Dosing pump for fine dosage of rinse aid
- Break tank with booster pump

OPTIONS

- 230V/3/50Hz
- Marine version
- Steam heated design, pressure 150-250kPa
- Drain pump
- Exhaust channel 200 x 100 mm
- ECO-FLOW condensing unit with heat recovery by the exhausted steam. (cold water connection is required)
- Additional booster heater for cold water connection
- Foldable shelf
- Connection power restriction
- Stainless couplings in the final rinse
- Panel on left side
- Connected to WD-PRM7
- WEB Tool - For external HACCP documentation

EXTRA EQUIPMENT

- Stainless steel basket 1040 x 500 mm

TECHNICAL DATA	WD-12
Washing pump (kW)	2x2.35
Booster heater (kW)	12
Booster heater (machine with cold water connection) (kW)*	2x12
Booster heater (condensing unit) kW*	15
Tank heater (kW)	9
Booster pump (kW)	0.67
Drain pump (kW)*	0.17
Tank volume (liter)	120
Weight, machine in operation (kg)	480
Enclosure class (IP)	55

* Option

CAPACITY AND OPERATING DATA	WD-12
Total washing time P1 (min) *	1.2
Total washing time P2 (min) *	3.2
Total washing time P3 (min) *	5.2
Max. capacity, baskets/hour (no.)	100
Water consumption rinsing/programme (liter) **	6 - 8
Noise level (dB(A))***	67

* Factory setting. The washing time can be adjusted.

** Applies under ideal conditions. The water consumption depends on local conditions. Fine adjustments can be made during installation.

*** Measured 1 metre from the side of the machine.

CONNECTION, MACHINE	WD-12
Total connected power (kW)	16.7/28.7***
Main fuse 400-415V 3N~ (A) *	35/50***
Max. connection area 400-415V 3N~ (L1-L3,N,PE) Cu (mm ²) **	16

* Other voltage on request.

** Cable 3 m H07RN-F is included.

*** Option.

■ Pot dishwasher with granules

WD-90GR HC

WD-90GR Flex



Wexiödisk 

www.wexiodisk.com

Mexico: a
his.

Our history – washing up the right way!

Wexiödisk started up in 1972

Wexiödisk is a Swedish company founded in 1972 which ever since it opened for business has focused on offering the institutional catering sector the absolute best in dishwashers. The extraordinarily high quality and new innovations soon meant successful sales results.

Quality

Our ambition for all our customers to be satisfied has been our ethos right from the very beginning. So we have focused on being able to provide reliable machines with low operating costs and a good working environment rather than a low purchase price, i.e. an early focus on Life Cycle Cost. Excellent cleaning results have always been seen as a matter of course.

Partners

We have selected our partners for the distribution, sales and service of our products with great care. We are in close contact with them, provide product support and training and ensure that we meet the customer's expectations together. Today Wexiödisk is the market leader in Scandinavia with a distribution network covering not only Europe but also, for example, Japan and Australia. In recent years Wexiödisk has also won several prestigious contracts within flight catering, which is a customer group with extremely high requirements.

Products

We will continue to invest significantly in product development in order to maintain and develop value to customers through a technologically advanced and competitive range of products. To assist us we have well-trained staff and hi-tech facilities. A complete production line, from plate-working to trial runs and equipped with automatic workshop machinery and robots, ensures top quality and availability.

Thinking about the environment

Dishwashers consume large amounts of energy, water and chemicals. So in recent years, Wexiödisk has concentrated more on the environmental side of things, which has led to the development of several new and unique products. ICS+ and DUPLUS are the names of two patented principles that provide an exceptionally reduced environmental impact and considerably lower operating costs.

Everyday life

Wexiödisk is based in Växjö in the south of Sweden. We have a working space of approx. 11,000 m² at our disposal and we have about 175 people working for us.

Our ambition

– Every new installation must result in a good reference!

Pot dishwashers, WD90GR, with granules for restaurants and institutional kitchens

Excellent wash results with granule technology

Wexiödisk's pot dishwashers with plastic granules have a high capacity and clean effectively, giving high levels of hygiene at very low operating costs.

Washing with granules reduces the need for normal preliminary tasks such as soaking and scrubbing. Items are washed with a mixture of water, plastic granules and detergent. Burnt-on food particles are removed quickly and effectively without soaking. Only loose food particles need to be scraped off before washing. A number of unique programme options, including a spin cycle, enable the items to be dried quickly to ensure maximum hygiene.

Low operating costs

The machine's unique spin cycle, combined with the rotation of items during the wash and final rinse cycles, produces excellent washing results and reduces the quantity of rinsing water required. Operating costs are minimized and drying results are considerably improved.

Effective washing and high capacity

The patented dual pump system has two washing tanks: one for water mixed with granules and one for water without any granules. With the dual pump system a reliable granule separation is achieved.

Maximum control of hygiene with HACCP

The built-in HACCP quality system involves a number of critical control points for hygiene. HACCP is a preventive system which ensures that hygiene requirements are met during the washing process. Critical points, such as temperature and water flow, are easily followed and secured by the control system.

Service-friendly

WD-90GR is designed with easy servicing in mind. Most components are easily accessible and service can normally be carried out from the front of the machine.

The position of the electrical cabinet at a convenient working height gives a clear overview of components.

Great flexibility – simple handling

The machine's six washing programmes with variable washing times make them ideal for a wide variety of items. Programmes with or without plastic granules allow both heavily soiled items and fragile plastic objects to be washed. Programmes without a spin cycle make it possible for items which cannot be secured adequately in the cassette.

Washing process

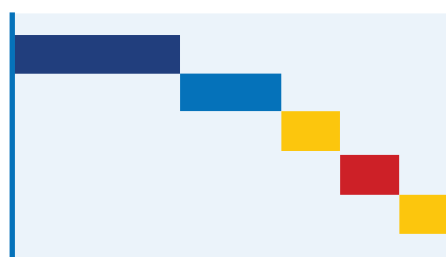

- *Washing with granules*
- *Washing without granules*
- *Spin cycle*
- *Final rinse*

■ **Washing with granules:** During the first stage, the items undergo a powerful treatment: a high pressure wash with a mixture of plastic granules, water and detergent.

■ **Washing without granules:** The items are washed with a mixture of water and detergent. During the chemical washing phase, the granules are rinsed off the items and down into the granule tank.

■ **Spin cycle:** After the washing without granules the spin cycle starts. The remaining water and granules are removed from the ware by the centrifugal power.

■ **Final rinse:** The items are given a final rinse with fresh water heated to 85°C via the booster heater, after which the final spin starts. The spin cycle removes the water from the items and enables fast drying for maximum hygiene.

A fantastic new day
– everyday!



■ WD-90GR Flex

Flexible

- **Excellent washing results and fast drying** with centrifuging spin cycle
- **Unique rectangular cassette** holds items of various shapes and sizes
- **High capacity** for washing small containers
- **Wide range of accessories** for variable items
- **8 x ½-containers per wash program**
-



– a compact dishwasher for restaurants and small institutional kitchens

The WD-90GR Flex dishwasher and peripherals and accessories make up a washing system which has been developed for restaurants and small institutional kitchens. The machine washes using a mixture of water, plastic granules and detergent, reducing the need for normal preliminary tasks such as soaking and scrubbing.

The washing cassette and accessories have been developed for various types of items such as pots, grills with GN dimensions and small mixing bowls. The machine offers high capacity when washing ½-containers and smaller containers with GN dimensions. The cassette holds four 1/1 containers or eight ½ containers. Cassette accessories are used for the simple washing of pots, grill pans, small containers and other food preparation accessories used by restaurants and institutional kitchens.

The washing system can be combined with other types of cassettes, increasing flexibility and capacity for different types of containers and heavily soiled loads.

The items are handled on the door of the machine to minimise granule spillage on the floor. The door can easily be lowered towards the floor to facilitate internal cleaning and the handling of components in the dishwashing area of the machine.

The WD-90GR Flex is a compact dishwasher. Used together with the sorting bench and its rinsing unit, it ensures the efficient flow of dishware items. The rinsing unit can be used both for rinsing dishware before washing and for cleaning the machine and dishwashing room.



*Table trolley, part. no. 3-7262
for transporting cassettes.*



*Sorting bench, part. no. 3-7270 for emptying
waste food and accumulating soiled items.*



*Holder for accessories, part. no.
3-7257. Fits on to the left- or
right-hand side of the machine.*

A selection of accessories for WD-90 GR Flex

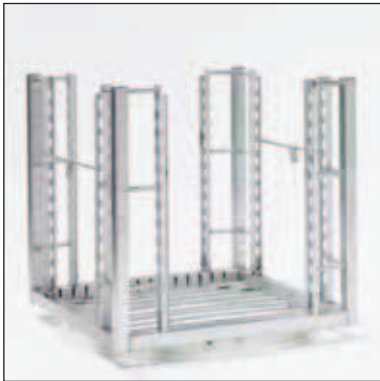

Square shaped cassette, part. no. 3-7276
Included in the delivery.



Side holder, part. no. 3-7354
3 pcs included in the delivery.



Lid holder, part. no. 3-7280
3 pcs included in the delivery.



Flexible insert, part. no. 3-7281
Used together with side holder.
Included in the delivery.



Utensil holder, part. no. 3-7277

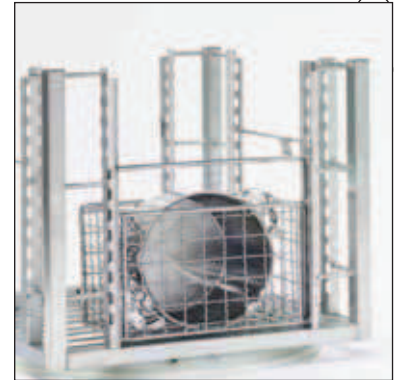

Wire basket, part. no. 3-7278

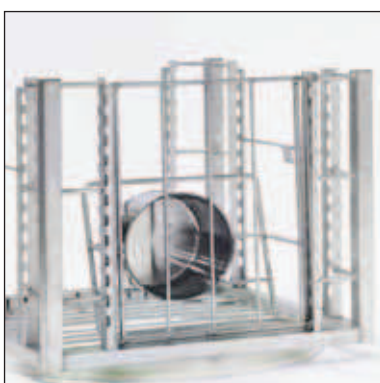

Holder, part. no. 3-7279
For small pots and bowls.



Allround holder, part. no. 3-7273
For pots with handles and ABC-
containers.



Holder for 1/3, 1/6, 1/9 containers,
part. no. 3-7282

The following accessories are included as standard:

Cassette	Part. no. 3-7276	1 pc
Lid holder	Part. no. 3-7280	3 pcs
Side holder	Part. no. 3-7354	3 pcs
Flexible insert	Part. no. 3-7281	1 pc



■ WD-90GR HC

High capacity

- **Excellent washing results and fast drying** with centrifuging spin cycle
- **Unique hexagonal cassette** with high capacity for washing containers, holds six ½ or 1/1 containers
- **High capacity** for washing GN containers
- **Wide range of accessories** for various items
- **Accessories** for washing 65 and 40 mm-deep 2/1 containers and baking trays 600x400 mm
- **Hinged door** enables for easy cleaning
- **Six wash programs with HACCP function**



– an effective dishwasher for institutional kitchens that wash containers

The WD-90GR and peripherals together with accessories make up a washing system which is ideal for small institutional kitchens with frequent loads of containers to be washed. The machine washes using a mixture of water, plastic granules and detergent, reducing the need for normal preliminary tasks such as soaking and scrubbing.

The machine's unique hexagonal cassette gives a high capacity for washing 1/1 and ½ containers. With a single insert, the cassette's dimensions allow two 2/1 containers, 65 and 40 mm deep and baking trays measuring 600x400 mm, both flat and those with a 20 mm lip, to be washed. Grills measuring 600x400 mm can also be washed.

The washing system can be combined with other types of cassettes, increasing flexibility and capacity for different types of containers and heavily soiled loads.

The WD-90GR HC is a compact machine. Used together with the sorting bench and its rinsing unit, it ensures the efficient flow of dishware items. The rinsing unit can be used both for rinsing dishware before washing and for cleaning the machine and dishwashing room.



*Table trolley, part. no. 3-7262,
for transporting cassettes.*



*Sorting bench, part. no. 3-7270 for emptying
waste food and accumulating soiled items.*



*Holder for accessories, part. no. 3-7257.
Fits to the left- or right-hand side of the
machine.*

A selection of accessories for WD-90GR HC

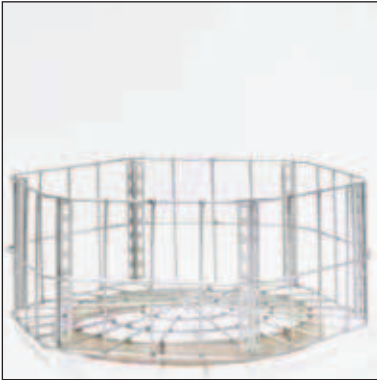

Hexagonal cassette, part. no. 3-7285
Included in the delivery.



Pot holder, part.no. 3-7255
For large pots. Included in the delivery.

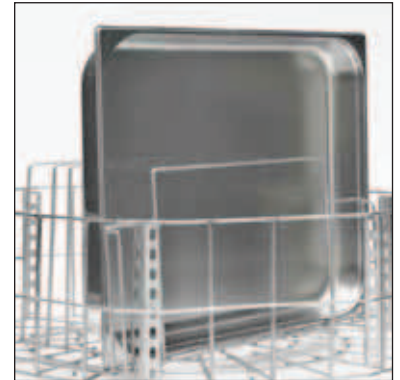

Grid, part. no. 3-7284
For 2/1 containers, grids, baking plates.
Included in the delivery.

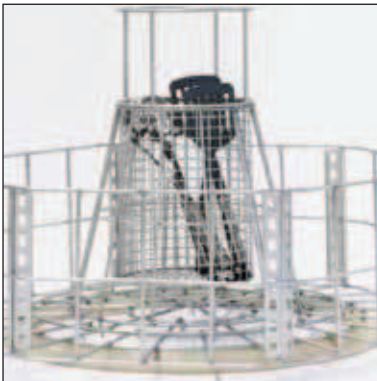

Utensil holder, part. no. 3-7251
For hexagonal cassette and round
basket.

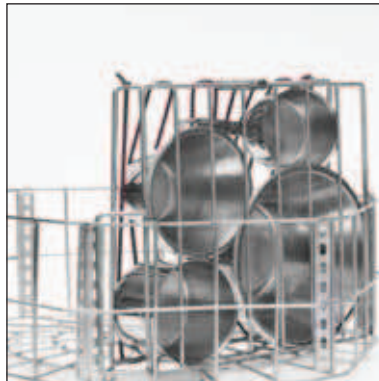

Flexible insert, part. no. 3-7283
Rubber rope holder for bowls and pots.



Pot holder for small pots, part. no. 3-7254



Pot holder, part. no. 3-7268
For frying plates and pots.



ABC- and lid holder, part. no. 3-7253



Basket for ABC containers,
part. no. 3-7259

The following accessories are included as standard:

Hexagonal cassette	Part. no. 3-7285	1 pc
Pot holder	Part. no. 3-7255	1 pc
Grid for 2/1 container	Part. no. 3-7284	1 pc

Part numbers - Extra equipment

Machine model		Part. no.
WD-90GR Flex	Pot dishwasher with standard equipment	3-7204
WD-90GR HC	Pot dishwasher with standard equipment	3-7206
Extra equipment WD-90GR Flex / WD-90GR HC		
Booster pump 230/400V		3-7235
Steam heating 50-250kPa 400V 3N~ 50Hz		3-7238Å
Connection for power monitor		3-7239
Connection for Sicotronic power monitor		3-7239S
Stainless steel connections		3-7240
Rinsing unit for sorting bench		3-7390
Grill cover for 50x50 dishwashing basket		3-7365
Booster pump 230/400V		3-7335
Air gap		3-7333
Steam heating 50-250kPa 400V 3N~ 50Hz		3-7338Å
Connection for power monitor		3-7339
Connection for power monitor Sicotronic		3-7339S
Infeed bench front-fed		3-7337
Cassette for standard 50x50 dishwashing basket		3-7364
Grill cover for 50x50 dishwashing basket		3-7365
Extension bench, infeed		3-7371
Connection track, special length		3-7375
Rinsing unit for infeed bench		3-7390
Infeed and outfeed track, length 2000 mm		3-7381

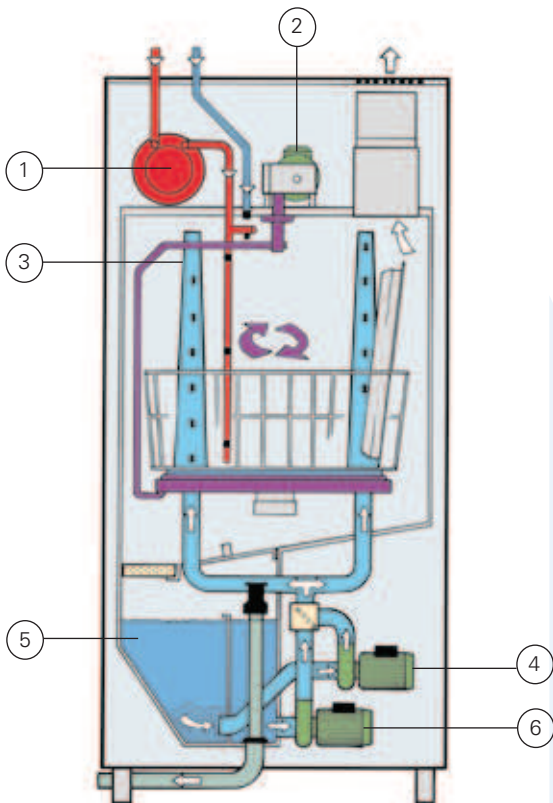

Diagram of a pot washing machine

1. *Booster heater*
2. *Cassette drive motor*
3. *Wash arms*
4. *Granule pump*
5. *Washing tank with granules*
6. *Washing pump*

Technical data

Technical data	WD-90GR Flex	WD-90GR HC
Granule pump (kW)	2.2	2.2
Rinse pump (kW)	1.5	1.5
Motor for the round table (kW)	0.18	0.18
Door drive motors (kW)	-	-
Booster heater (kW)	9	9
Heater tank (kW)	9	9
Tank volume (litres)	100	100
Weight, machine in operation (kg)	430	430
Granule volume (litres)	5	5
Degree of protection (IP)	55	55

Capacity and operation data	WD-90GR Flex	WD-90GR HC
Total time/wash program 1** (min)	5	5
Total time/wash program 2** (min)	8	8
Total time/wash program 3** (min)	10.3	10.3
Total time/wash program 4** (min)	2.3	2.3
Total time/wash program 5** (min)	3.8	3.8
Total time/wash program 6** (min)	6.8	6.8
Capacity, max (1/1 containers/program)****	4	6
Capacity / h, Pr 1 (1/1-containers) incl. handling *****(pc)	45	68
Capacity / h, Pr 1 (1/2-containers) incl. handling *****(pc)	90	68
Cold water consumption rinse/program (litres) *****	3.5 - 5	3.5 - 5
Water consumption cooling/program (litres) *****	0 - 1.5	0 - 1.5
Energy consumption (kWh of connected power)	70-90%	70-90%
Steam consumption *** (kg/h)	15	15
Sound level* (dB(A))	68	68
Max. surface temp. at room temp. 20°C (°C)	30	30

* Measured 1 metre from the machine

** Factory setting. The wash time is adjustable

*** Steam heated machine

**** Max. capacity depending on the depth of the containers.

***** Applies under ideal conditions and program using spinning.

The water consumption depends on local conditions. An exact adjustment is made during installation.

Connection, electrically heated machine	WD-90GR Flex	WD-90GR HC
Total connected power (kW)	11.3	11.3
Main fuse 400V 3N~ (A)*	20	20
Max.conn.area 400V 3N~ (L1-L3,N,PE) Cu (mm ²)	6	6

* Other voltages on request

Connection, steam heated machine 50-250 kPa	WD-90GR Flex	WD-90GR HC
Total conn.power (kW)	2.4	2.4
Main fuse 400V 3N~(A)*	16	16
Max.conn.area 400V 3N~ (L1-L3, N, PE) Cu (mm ²)	6	6
Steam connection (internal thread)	R ½"	R ½"
Connection condense water (internal thread)	R ½"	R ½"

* Other voltages on request

Size and weight for transportation	WD-90GR Flex	WD-90GR HC
Size * LxWxH (mm)	1060x900x1950	1060x900x1950
Weight * (kg)	340	340

* Packaging included

Connection water, drain and ventilation	WD-90GR Flex	WD-90GR HC
Water quality, hardness (°dH)	2 - 7	2 - 7
Cold water connection 5-12°C (internal thread)	R ½"	R ½"
Hot water connection 55-70°C (internal thread)	R ½"	R ½"
Drain connection, PP pipe (ø mm)	50	50
Water capacity warm water, pressure (kPa)	250	250
Water capacity warm water, flow (litres/min)	15	15
Water capacity cold water cooling, min/max pressure (kPa)	100/600	100/600
Floor drain, capacity (litres/sec)	3	3
Ventilation of the machine (m³/h)	600	600

■ Dimensional drawings

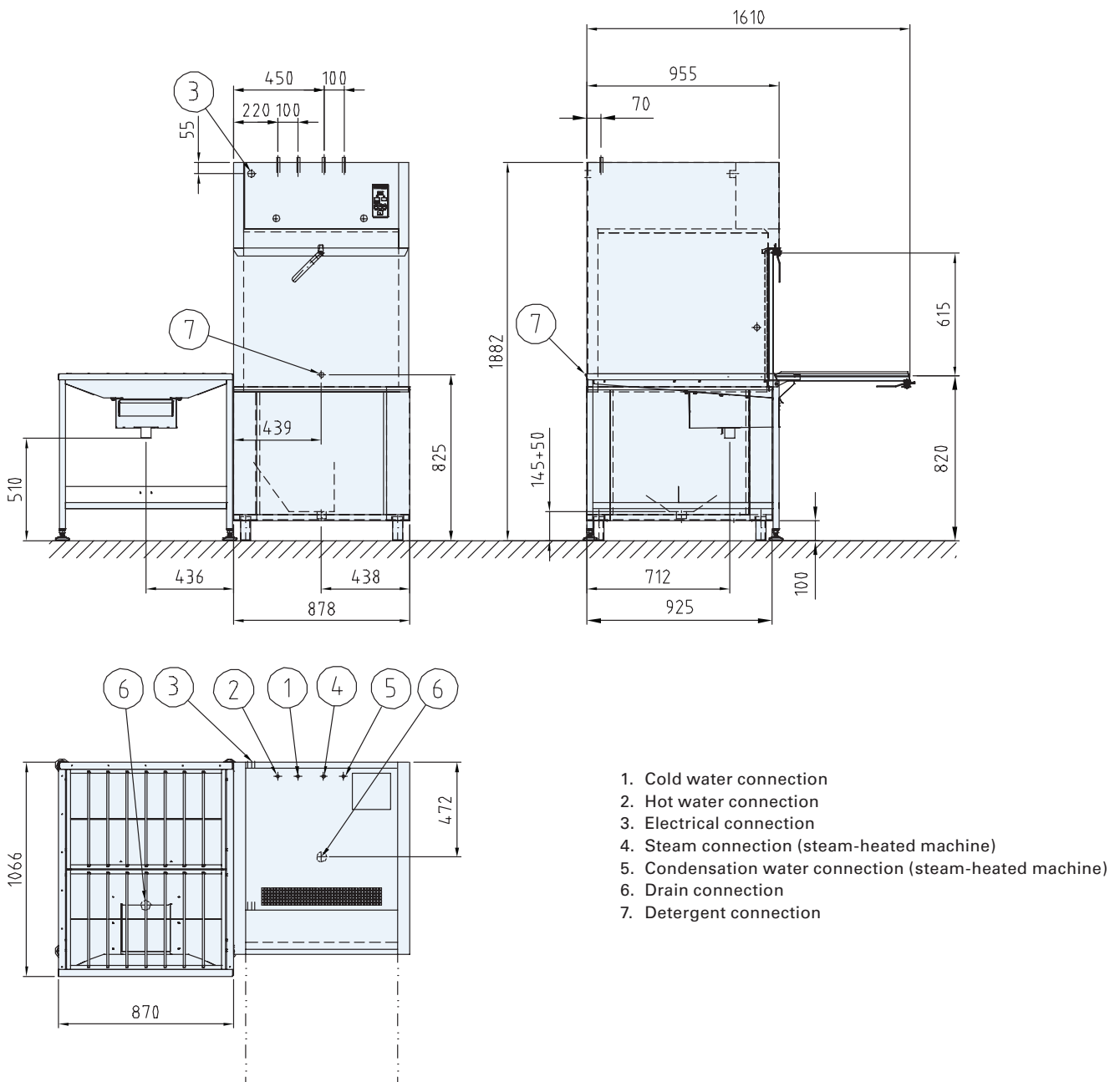



Telephone: +46 470 77 12 00

Fax: +46 470 237 52

Address: Mårdvägen 4
SE-352 45 Växjö
SWEDEN

E-mail: wexiodisk@wexiodisk.com

Wexiödisk 

www.wexiodisk.com

■ Pot dishwasher with granules

WD-90GR HC

WD-90GR Flex



Wexiödisk 

www.wexiodisk.com

Mexico: a
his.

Our history – washing up the right way!

Wexiödisk started up in 1972

Wexiödisk is a Swedish company founded in 1972 which ever since it opened for business has focused on offering the institutional catering sector the absolute best in dishwashers. The extraordinarily high quality and new innovations soon meant successful sales results.

Quality

Our ambition for all our customers to be satisfied has been our ethos right from the very beginning. So we have focused on being able to provide reliable machines with low operating costs and a good working environment rather than a low purchase price, i.e. an early focus on Life Cycle Cost. Excellent cleaning results have always been seen as a matter of course.

Partners

We have selected our partners for the distribution, sales and service of our products with great care. We are in close contact with them, provide product support and training and ensure that we meet the customer's expectations together. Today Wexiödisk is the market leader in Scandinavia with a distribution network covering not only Europe but also, for example, Japan and Australia. In recent years Wexiödisk has also won several prestigious contracts within flight catering, which is a customer group with extremely high requirements.

Products

We will continue to invest significantly in product development in order to maintain and develop value to customers through a technologically advanced and competitive range of products. To assist us we have well-trained staff and hi-tech facilities. A complete production line, from plate-working to trial runs and equipped with automatic workshop machinery and robots, ensures top quality and availability.

Thinking about the environment

Dishwashers consume large amounts of energy, water and chemicals. So in recent years, Wexiödisk has concentrated more on the environmental side of things, which has led to the development of several new and unique products. ICS+ and DUPLUS are the names of two patented principles that provide an exceptionally reduced environmental impact and considerably lower operating costs.

Everyday life

Wexiödisk is based in Växjö in the south of Sweden. We have a working space of approx. 11,000 m² at our disposal and we have about 175 people working for us.

Our ambition

– Every new installation must result in a good reference!

Pot dishwashers, WD90GR, with granules for restaurants and institutional kitchens

Excellent wash results with granule technology

Wexiödisk's pot dishwashers with plastic granules have a high capacity and clean effectively, giving high levels of hygiene at very low operating costs.

Washing with granules reduces the need for normal preliminary tasks such as soaking and scrubbing. Items are washed with a mixture of water, plastic granules and detergent. Burnt-on food particles are removed quickly and effectively without soaking. Only loose food particles need to be scraped off before washing. A number of unique programme options, including a spin cycle, enable the items to be dried quickly to ensure maximum hygiene.

Low operating costs

The machine's unique spin cycle, combined with the rotation of items during the wash and final rinse cycles, produces excellent washing results and reduces the quantity of rinsing water required. Operating costs are minimized and drying results are considerably improved.

Effective washing and high capacity

The patented dual pump system has two washing tanks: one for water mixed with granules and one for water without any granules. With the dual pump system a reliable granule separation is achieved.

Maximum control of hygiene with HACCP

The built-in HACCP quality system involves a number of critical control points for hygiene. HACCP is a preventive system which ensures that hygiene requirements are met during the washing process. Critical points, such as temperature and water flow, are easily followed and secured by the control system.

Service-friendly

WD-90GR is designed with easy servicing in mind. Most components are easily accessible and service can normally be carried out from the front of the machine.

The position of the electrical cabinet at a convenient working height gives a clear overview of components.

Great flexibility – simple handling

The machine's six washing programmes with variable washing times make them ideal for a wide variety of items. Programmes with or without plastic granules allow both heavily soiled items and fragile plastic objects to be washed. Programmes without a spin cycle make it possible for items which cannot be secured adequately in the cassette.

Washing process

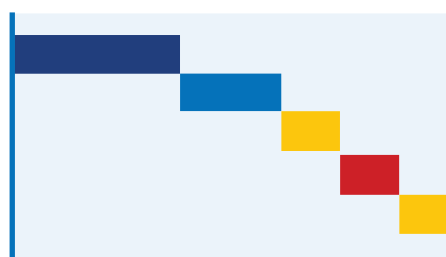

- *Washing with granules*
- *Washing without granules*
- *Spin cycle*
- *Final rinse*

■ **Washing with granules:** During the first stage, the items undergo a powerful treatment: a high pressure wash with a mixture of plastic granules, water and detergent.

■ **Washing without granules:** The items are washed with a mixture of water and detergent. During the chemical washing phase, the granules are rinsed off the items and down into the granule tank.

■ **Spin cycle:** After the washing without granules the spin cycle starts. The remaining water and granules are removed from the ware by the centrifugal power.

■ **Final rinse:** The items are given a final rinse with fresh water heated to 85°C via the booster heater, after which the final spin starts. The spin cycle removes the water from the items and enables fast drying for maximum hygiene.

A fantastic new day
– everyday!



■ WD-90GR Flex

Flexible

- **Excellent washing results and fast drying** with centrifuging spin cycle
- **Unique rectangular cassette** holds items of various shapes and sizes
- **High capacity** for washing small containers
- **Wide range of accessories** for variable items
- **8 x ½-containers per wash program**
-



– a compact dishwasher for restaurants and small institutional kitchens

The WD-90GR Flex dishwasher and peripherals and accessories make up a washing system which has been developed for restaurants and small institutional kitchens. The machine washes using a mixture of water, plastic granules and detergent, reducing the need for normal preliminary tasks such as soaking and scrubbing.

The washing cassette and accessories have been developed for various types of items such as pots, grills with GN dimensions and small mixing bowls. The machine offers high capacity when washing ½-containers and smaller containers with GN dimensions. The cassette holds four 1/1 containers or eight ½ containers. Cassette accessories are used for the simple washing of pots, grill pans, small containers and other food preparation accessories used by restaurants and institutional kitchens.

The washing system can be combined with other types of cassettes, increasing flexibility and capacity for different types of containers and heavily soiled loads.

The items are handled on the door of the machine to minimise granule spillage on the floor. The door can easily be lowered towards the floor to facilitate internal cleaning and the handling of components in the dishwashing area of the machine.

The WD-90GR Flex is a compact dishwasher. Used together with the sorting bench and its rinsing unit, it ensures the efficient flow of dishware items. The rinsing unit can be used both for rinsing dishware before washing and for cleaning the machine and dishwashing room.



*Table trolley, part. no. 3-7262
for transporting cassettes.*



*Sorting bench, part. no. 3-7270 for emptying
waste food and accumulating soiled items.*



*Holder for accessories, part. no.
3-7257. Fits on to the left- or
right-hand side of the machine.*

A selection of accessories for WD-90 GR Flex

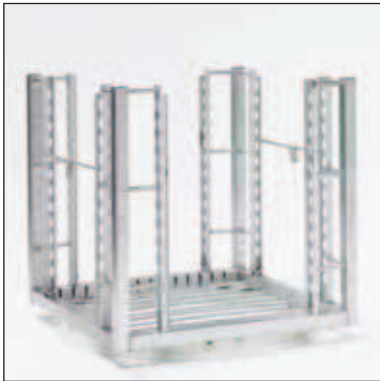

Square shaped cassette, part. no. 3-7276
Included in the delivery.



Side holder, part. no. 3-7354
3 pcs included in the delivery.



Lid holder, part. no. 3-7280
3 pcs included in the delivery.



Flexible insert, part. no. 3-7281
Used together with side holder.
Included in the delivery.



Utensil holder, part. no. 3-7277

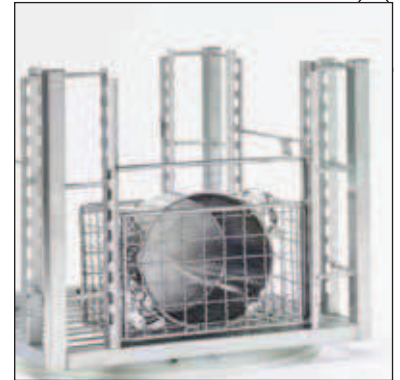

Wire basket, part. no. 3-7278

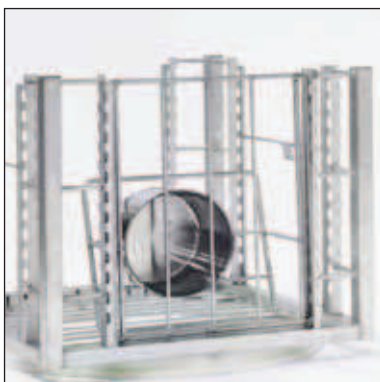

Holder, part. no. 3-7279
For small pots and bowls.



Allround holder, part. no. 3-7273
For pots with handles and ABC-
containers.



Holder for 1/3, 1/6, 1/9 containers,
part. no. 3-7282

The following accessories are included as standard:

Cassette	Part. no. 3-7276	1 pc
Lid holder	Part. no. 3-7280	3 pcs
Side holder	Part. no. 3-7354	3 pcs
Flexible insert	Part. no. 3-7281	1 pc



■ WD-90GR HC

High capacity

- **Excellent washing results and fast drying** with centrifuging spin cycle
- **Unique hexagonal cassette** with high capacity for washing containers, holds six ½ or 1/1 containers
- **High capacity** for washing GN containers
- **Wide range of accessories** for various items
- **Accessories** for washing 65 and 40 mm-deep 2/1 containers and baking trays 600x400 mm
- **Hinged door** enables for easy cleaning
- **Six wash programs with HACCP function**



– an effective dishwasher for institutional kitchens that wash containers

The WD-90GR and peripherals together with accessories make up a washing system which is ideal for small institutional kitchens with frequent loads of containers to be washed. The machine washes using a mixture of water, plastic granules and detergent, reducing the need for normal preliminary tasks such as soaking and scrubbing.

The machine's unique hexagonal cassette gives a high capacity for washing 1/1 and 1/2 containers. With a single insert, the cassette's dimensions allow two 2/1 containers, 65 and 40 mm deep and baking trays measuring 600x400 mm, both flat and those with a 20 mm lip, to be washed. Grills measuring 600x400 mm can also be washed.

The washing system can be combined with other types of cassettes, increasing flexibility and capacity for different types of containers and heavily soiled loads.

The WD-90GR HC is a compact machine. Used together with the sorting bench and its rinsing unit, it ensures the efficient flow of dishware items. The rinsing unit can be used both for rinsing dishware before washing and for cleaning the machine and dishwashing room.



*Table trolley, part. no. 3-7262,
for transporting cassettes.*



*Sorting bench, part. no. 3-7270 for emptying
waste food and accumulating soiled items.*



*Holder for accessories, part. no. 3-7257.
Fits to the left- or right-hand side of the
machine.*

A selection of accessories for WD-90GR HC

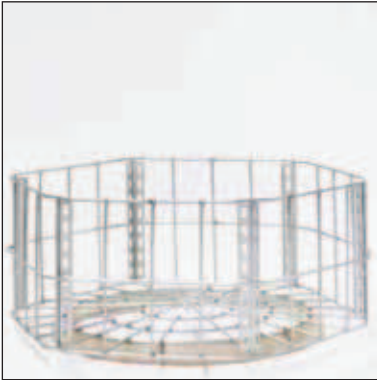

Hexagonal cassette, part. no. 3-7285
Included in the delivery.



Pot holder, part. no. 3-7255
For large pots. Included in the delivery.

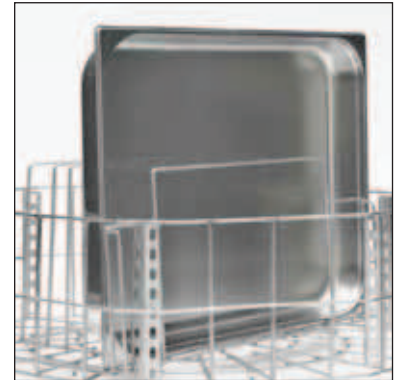

Grid, part. no. 3-7284
For 2/1 containers, grids, baking plates.
Included in the delivery.

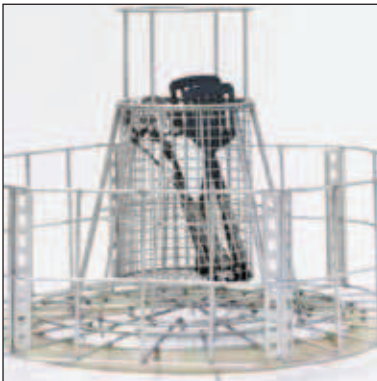

Utensil holder, part. no. 3-7251
For hexagonal cassette and round
basket.

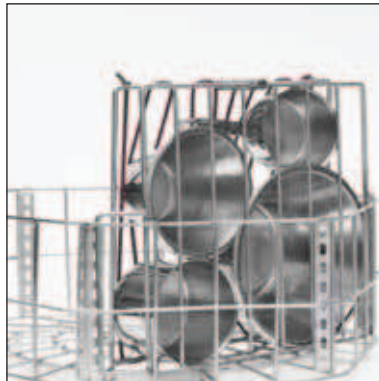

Flexible insert, part. no. 3-7283
Rubber rope holder for bowls and pots.



Pot holder for small pots, part. no. 3-7254



Pot holder, part. no. 3-7268
For frying plates and pots.



ABC- and lid holder, part. no. 3-7253



Basket for ABC containers,
part. no. 3-7259

The following accessories are included as standard:

Hexagonal cassette	Part. no. 3-7285	1 pc
Pot holder	Part. no. 3-7255	1 pc
Grid for 2/1 container	Part. no. 3-7284	1 pc

Part numbers - Extra equipment

Machine model		Part. no.
WD-90GR Flex	Pot dishwasher with standard equipment	3-7204
WD-90GR HC	Pot dishwasher with standard equipment	3-7206
Extra equipment WD-90GR Flex / WD-90GR HC		
Booster pump 230/400V		3-7235
Steam heating 50-250kPa 400V 3N~ 50Hz		3-7238Å
Connection for power monitor		3-7239
Connection for Sicotronic power monitor		3-7239S
Stainless steel connections		3-7240
Rinsing unit for sorting bench		3-7390
Grill cover for 50x50 dishwashing basket		3-7365
Booster pump 230/400V		3-7335
Air gap		3-7333
Steam heating 50-250kPa 400V 3N~ 50Hz		3-7338Å
Connection for power monitor		3-7339
Connection for power monitor Sicotronic		3-7339S
Infeed bench front-fed		3-7337
Cassette for standard 50x50 dishwashing basket		3-7364
Grill cover for 50x50 dishwashing basket		3-7365
Extension bench, infeed		3-7371
Connection track, special length		3-7375
Rinsing unit for infeed bench		3-7390
Infeed and outfeed track, length 2000 mm		3-7381

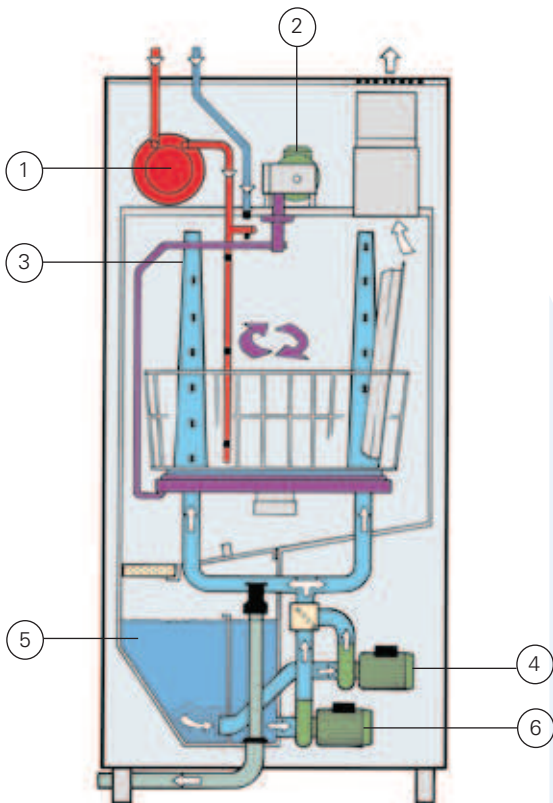

Diagram of a pot washing machine

1. *Booster heater*
2. *Cassette drive motor*
3. *Wash arms*
4. *Granule pump*
5. *Washing tank with granules*
6. *Washing pump*

Technical data

Technical data	WD-90GR Flex	WD-90GR HC
Granule pump (kW)	2.2	2.2
Rinse pump (kW)	1.5	1.5
Motor for the round table (kW)	0.18	0.18
Door drive motors (kW)	-	-
Booster heater (kW)	9	9
Heater tank (kW)	9	9
Tank volume (litres)	100	100
Weight, machine in operation (kg)	430	430
Granule volume (litres)	5	5
Degree of protection (IP)	55	55

Capacity and operation data	WD-90GR Flex	WD-90GR HC
Total time/wash program 1** (min)	5	5
Total time/wash program 2** (min)	8	8
Total time/wash program 3** (min)	10.3	10.3
Total time/wash program 4** (min)	2.3	2.3
Total time/wash program 5** (min)	3.8	3.8
Total time/wash program 6** (min)	6.8	6.8
Capacity, max (1/1 containers/program)****	4	6
Capacity / h, Pr 1 (1/1-containers) incl. handling ****(pc)	45	68
Capacity / h, Pr 1 (1/2-containers) incl. handling ****(pc)	90	68
Cold water consumption rinse/program (litres) *****	3.5 - 5	3.5 - 5
Water consumption cooling/program (litres) *****	0 - 1.5	0 - 1.5
Energy consumption (kWh of connected power)	70-90%	70-90%
Steam consumption *** (kg/h)	15	15
Sound level* (dB(A))	68	68
Max. surface temp. at room temp. 20°C (°C)	30	30

* Measured 1 metre from the machine

** Factory setting. The wash time is adjustable

*** Steam heated machine

**** Max. capacity depending on the depth of the containers.

***** Applies under ideal conditions and program using spinning.

The water consumption depends on local conditions. An exact adjustment is made during installation.

Connection, electrically heated machine	WD-90GR Flex	WD-90GR HC
Total connected power (kW)	11.3	11.3
Main fuse 400V 3N~ (A)*	20	20
Max.conn.area 400V 3N~ (L1-L3,N,PE) Cu (mm ²)	6	6

* Other voltages on request

Connection, steam heated machine 50-250 kPa	WD-90GR Flex	WD-90GR HC
Total conn.power (kW)	2.4	2.4
Main fuse 400V 3N~(A)*	16	16
Max.conn.area 400V 3N~ (L1-L3, N, PE) Cu (mm ²)	6	6
Steam connection (internal thread)	R ½"	R ½"
Connection condense water (internal thread)	R ½"	R ½"

* Other voltages on request

Size and weight for transportation	WD-90GR Flex	WD-90GR HC
Size * LxWxH (mm)	1060x900x1950	1060x900x1950
Weight * (kg)	340	340

* Packaging included

Connection water, drain and ventilation	WD-90GR Flex	WD-90GR HC
Water quality, hardness (°dH)	2 - 7	2 - 7
Cold water connection 5-12°C (internal thread)	R ½"	R ½"
Hot water connection 55-70°C (internal thread)	R ½"	R ½"
Drain connection, PP pipe (ø mm)	50	50
Water capacity warm water, pressure (kPa)	250	250
Water capacity warm water, flow (litres/min)	15	15
Water capacity cold water cooling, min/max pressure (kPa)	100/600	100/600
Floor drain, capacity (litres/sec)	3	3
Ventilation of the machine (m³/h)	600	600

■ Dimensional drawings

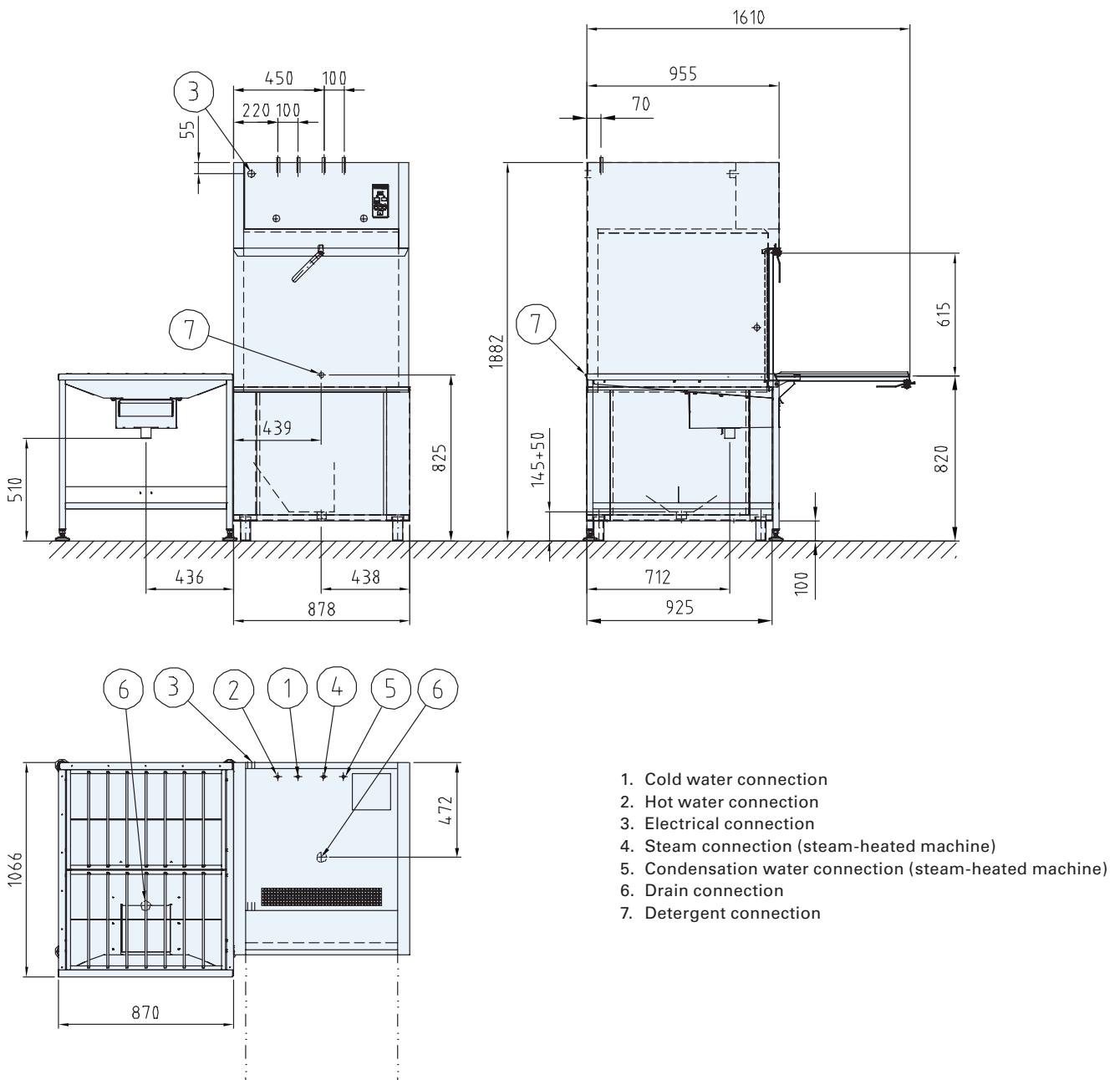



Telephone: +46 470 77 12 00

Fax: +46 470 237 52

Address: Mårdvägen 4
SE-352 45 Växjö
SWEDEN

E-mail: wexiodisk@wexiodisk.com

Wexiödisk 

www.wexiodisk.com

WD-90 DUO

POTWASHER



Wexiödisk 

POTWASHER

WD-90 DUO

> **Efficient and user-friendly**

– less manual handling.

> **No strenuous prewash**

– granules scrub away the food residue in the machine.

> **High capacity in small areas**

– the unique DUO-system washes everything from large pots to small glasses.

> **Fast drying**

– efficient and energy-saving centrifugal spin cycle.

> **Easy to use**

– user-friendly panel with nine programmes.

> **Easy to serve**

– all service is managed from the front or side.

> **Robust and durable**

– made from stainless steel and high quality components.

> **Easy to clean**

– improves hygiene.

> **HACCP documentation**

– a system that simplifies self checking.

> **Ergonomic features**

– automatic hood lift means less strain and a better working environment.

> **Energy efficient heat recovery**

– the condensing unit removes and recycles the heat from the previous wash (optional).



Wexiödisk 



EFFICIENT AND USER-FRIENDLY

WD-90 DUO is an innovative potwasher that saves the environment and operator, as well as energy and money. Granules replace the strenuous prewash and the fast wash cycles with efficient drying ensure a hygienic and energy-efficient wash from beginning to end. And obviously, with sparkling clean result. The size, the high capacity and the ability to wash everything in the same machine makes WD-90 DUO perfect for smaller to medium restaurants with a flexible flow of dishware.



PRODUCT BENEFITS



NO STRENUOUS PREWASH

The small plastic granules reduce the need for time-consuming soaking and strenuous scrubbing. Faster cleaning and more environmentally friendly than manual pre-washing – and with significantly lower operating costs.

ROBUST AND DURABLE

WD-90 DUO is designed to withstand daily use in large-scale catering establishments. Stainless steel and high quality components ensure an extra long service life.

HIGH CAPACITY IN SMALL AREAS

The unique DUO-system makes it easy to switch from washing pots, pans and canteens to glass and china. Two functions in the same machine save both space and time.



EASY TO USE

Nine different programs in a user-friendly panel. Three for pot wash with granules, three for pot wash with water only and three for glass and china. It's easy to see and choose the right kind of dishes to be washed.

EASY TO CLEAN

The wash arms are easy to remove for cleaning. This ensures high levels of hygiene.

ERGONOMY AND WORKING ENVIRONMENT

The automatic hood reduces the risk of shoulder or arm strain injuries. At the end of the wash cycle the hood is raised a few centimetres in order to release the hot steam, before it opens to its highest position. The hood is lowered with an easy operating button.

ENERGY EFFICIENT HEAT RECOVERY

Save even more energy and enjoy a significantly improved working environment with the condensing unit (optional). It removes excess steam from the previous wash and recycles the heat for the next. At the same time cold air is blown into the dish room, which gives a better climate and reduces the need for ventilation significantly.

FAST DRYING

The efficient and unique centrifugal function dries the dishes in a very short time and saves energy as well. The function also runs between the wash and rinse cycles, which means that even less water is being used to produce sparkling clean dishes.

HACCP DOCUMENTATION

The integrated document tool WEB Tool ensures automatic reporting of environmental and hygiene data in accordance with HACCP. As an option you can also get detailed reports about the operation, which gives you more control over costs.



INSTALLATION OPTIONS

WD-90 DUO has a flexible design to suit as many types of kitchens as possible. Also where space is restricted. It can therefore be installed in a variety of ways, depending on the conditions of your kitchen.

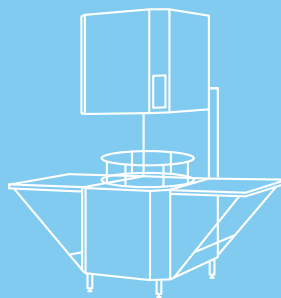

STRAIGHT INSTALLATION

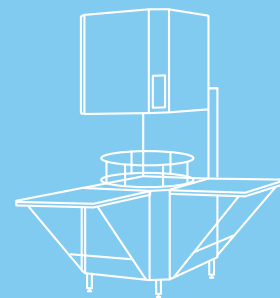

CORNER INSTALLATION

INNOVATION WITH ATTENTION TO EVERY **DETAIL**

Nature is a fantastic source of inspiration, packed with functional details of such quality – just like a dishwasher from Wexiödisk.

The sea eagle [*Haliaeetus albicilla*] is Northern Europe's biggest bird of prey, with a wingspan of nearly 2.5 metres. Each wing weighs just over a kilo, but per gram it is stronger than an aircraft wing.



Wexiödisk^W



TECHNICAL DATA

TECHNICAL DATA	WD-90 DUO
Granule wash pump (kW)	2.2
Wash pump pot wash (kW)	1.5
Wash pump (kW)	0.74
Booster heater (kW)	9 / 12*
Heater tank (kW)	9
Tank volume (litres)	90
Rinse/booster pump (kW)	0.67
Heat recovery fan (kW)	0.129
Motor rotating table (kW)	0.55
Recommended granule amount (litres)	5
Weight machine in operation with condensing unit (kg)	455
Weight machine in operation without condensing unit (kg)	430
Degree of protection (IP)	55

CAPACITY AND OPERATION DATA	WD-90 DUO
Capacity max number GN 1/1-canteens per wash / Capacity max number GN 1/1-canteens per hour	6 + 1 / 191
Capacity normal wash for glass and china, max number of baskets per hour	46
Normal wash for glass and china	
Programme 1 (min)	1.3
Programme 2 (min)	1.8
Programme 3 (min)	3.3
Heavily soiled wash with granules	
Programme 1 (min)	2.2
Programme 2 (min)	4.2
Programme 3 (min)	6.2
Heavily soiled wash without granules	
Programme 4 (min)	2.2
Programme 5 (min)	4.0
Programme 6 (min)	6.2
Programme for collecting the granules (min)	5.4
Water consumption/rinse (litres/programme)	4 - 6
Water consumption/cooling (litres/programme)	0 - 1.5
Sound level, LpA, dB(A)	70
Max. surface temp. at room temp. 20 degrees C	35

CONNECTION, MACHINE	WD-90 DUO
Total connected power	11.7 / 14.7*
Main fuse (400-415V, 3~ 50 Hz) (A)	20 / 25*
Max. connection area (400-415V, 3~ 50 Hz) (mm ²)	6

CONNECTION, WATER, DRAIN AND VENTILATION	WD-90 DUO
Hot water (50-70 °C) external thread	1/2"
Cold water (5-12 °C) external thread	1/2"
Drain PP-pipe (mm)	Ø 50
Water pressure, max (kPa)	600
Water pressure, min (kPa)	50
Water capacity flow (litres/min)	5
Floor drain (litres/sec)	3
Heat load to the room WD-90 DUO standard (total, sensible, latent) (kW)	1.5 / 1.0 / 0.5
Heat load to the room WD-90 DUO with condensing unit (total, sensible, latent) (kW)	1.2 / 0.7 / 0.5

SIZE AND WEIGHT FOR TRANSPORTATION	WD-90 DUO
Size L x W x H (mm)	1140 x 960 x 1950
Weight machine incl. packaging (kg)	340
Weight machine + condensing unit incl. packaging (kg)	415

* Applies for WD-90 DUO with the optional condensing unit



EXTRA EQUIPMENT



CIRCULAR POT WASH BASKET

Capacity 6+1 GN 1/1 65 mm.
The basket is adapted to accommodate canteens of various sizes.
Product no 209.7450

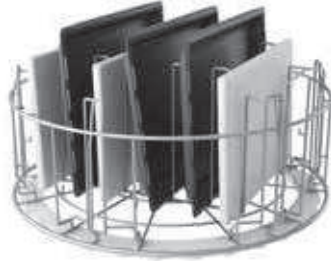

HOLDER

For 2/1 containers, grids and baking plates.
Product no 209.7484



FLEXIBLE INSERT

Product no 209.7481

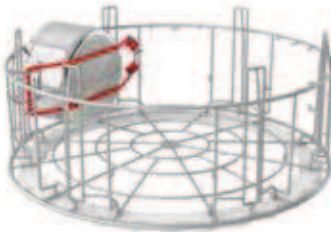

RUBBER STRAP

Product no 209.7272



SUPPORT FOR POTS AND PANS

Product no 209.7252



GRANULES 10 KG

Product no 209.7260



FOLDING TABLE RIGHT

Product no 209.7452 (right)

FOLDING TABLE LEFT

Product no 209.7453 (left)

FOLDING TABLE FRONT

Product no 209.7451 (front)

CUTLERY AND UTENSIL HOLDER

Product no 209.7251



TROLLEY

Product no 209.7462

SCRAPER

Product no 209.7261



SORTING BENCH

Product no 209.7270



DIMENSIONAL DRAWINGS

WD-90 DUO standard

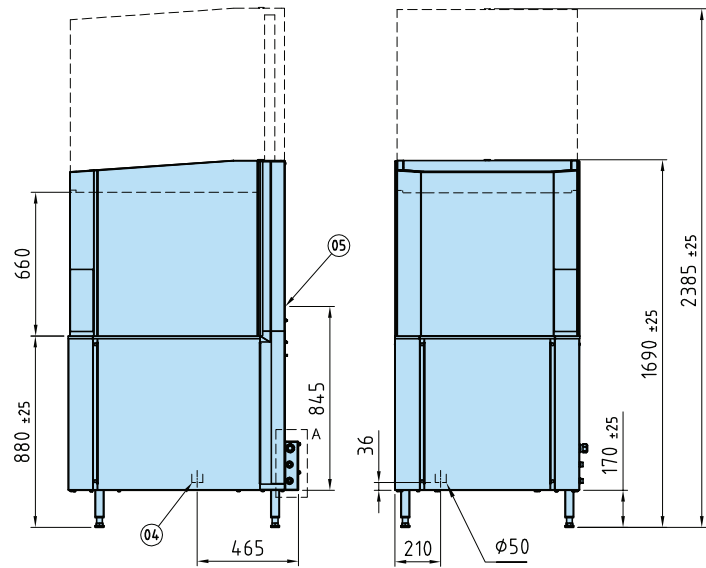
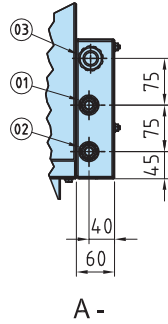
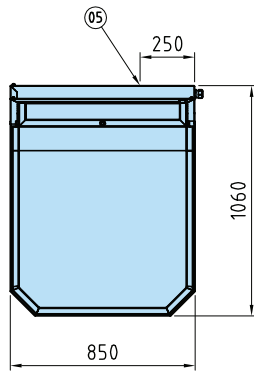

WD-90 DUO with condensing unit

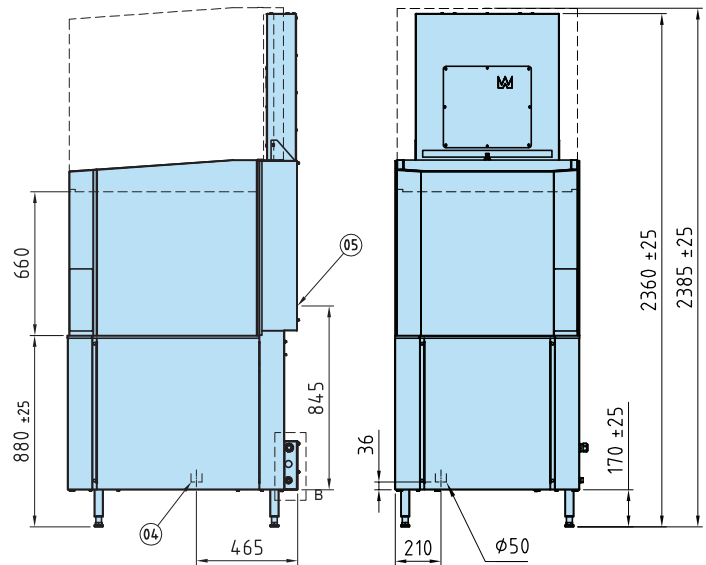
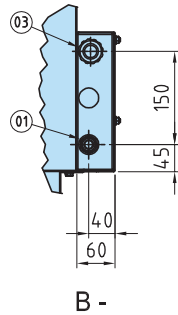
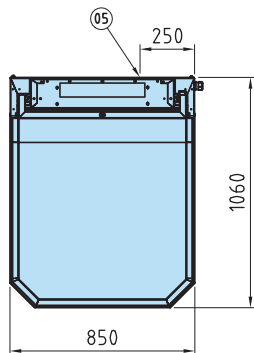

- 01. Cold water connection
- 02. Hot water connection
- 03. Electrical connection
- 04. Drain
- 05. Detergent connection
- 06. Sink connection

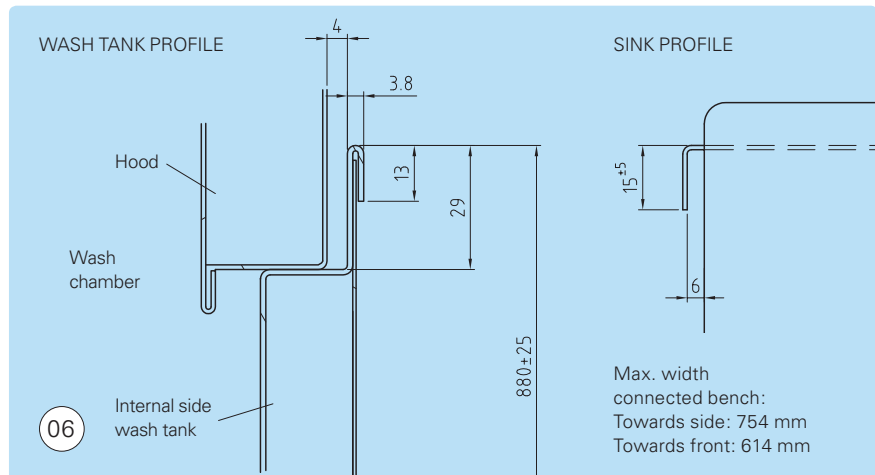

Wexiödisk – professional pride in every detail

Wexiödisk is a Swedish company based in Växjö. Since the beginning of 1972 our ambition has been to create the best and most user-friendly dishwashing solution in the world. With experience, knowledge and customer benefit as our catch words, we strive to make every day in your kitchen efficient and manageable.

But not at any price. The environment has always been, and will always be, at the heart of what we do at Wexiödisk. We are aware of the fact that the potwasher uses the most energy, water and chemicals in the kitchen. We therefore have an ambition for every newly developed machine to use less than the previous.

Our professional pride has so far resulted in a series of patented innovations and a leading position in everything to do with cleaning dishes in a professional kitchen.

We are also aware of how important the potwasher is for an efficient kitchen. Every day, all year round. Our partners who distribute, sell and service our products worldwide are therefore chosen with great care. Each installation should be a good reference. We therefore expect our partners to share our ambitions, be readily available and cost effective.



Wexiödisk^W



Wexiödisk

TELEPHONE: +46 470 77 12 00 FAX: +46 470 237 52
ADDRESS: Mårdvägen 4 SE-352 45 Växjö SWEDEN
E-MAIL: wexiodisk@wexiodisk.com WEBB: www.wexiodisk.com

■ Pot dishwasher with granules WD-100GR



Wexiödisk 

www.wexiodisk.com

■ Our history – clean dishes



Wexiödisk was founded in 1972

The three founder members, with their experience of producing and developing catering equipment, saw the means of offering a range of dishwashers within the reach of distributors outside large established organisations. Thanks to knowledge, foresight and also the desire to be able to offer some really good products, a range of quality machines was created. The extraordinarily high quality and new innovations soon led to successful sales results, even outside Sweden.

Our quality

Our ambition for all our customers to be satisfied has been our ethos right from the very beginning. So we focus on being able to provide safe machines with low operating costs as well as a good working environment rather than on a low purchase price. In other words, an early focus on Life Cycle Cost. Excellent dishwashing results are a given.

Our partners

We have carefully chosen our partners who distribute, sell and service our products. Together, through close dialogue, a good product support system and training, we fulfil our customers' expectations. Today Wexiödisk is the leading supplier in Scandinavia, with a distribution network not only in Europe but also in Japan and Australia, amongst other countries. In recent years Wexiödisk has also won prestigious contracts in the inflight catering sector, a customer group with very high demands.

Our products

We will continue to focus on product development, in order to maintain and improve customer satisfaction by having a competitive and technically advanced product range. To make this a reality, we use the latest technology together with skilled and competent employees. A complete production process, from raw materials to final product testing, equipped with automated machines and robots ensures quality and accessibility.

Our environmental focus

Dishwashers use large amounts of energy, water and chemicals. As a result, in the last few years Wexiödisk has focused even more on the environmental aspect of its products, something which has led to the development of new unique products. ICS+ and DUPLUS are two of the new patented techniques that reduce the environmental impact. This is also reflected in the considerably lower operating costs.

Everyday facts

Wexiödisk is situated in Växjö in the south of Sweden. The plant is about 11,000 m². Wexiödisk employs about 175 people.

Our ambition

Every new installation must result in a good reference!

Wexiödisk 



■ An ergonomic granule dishwasher for kitchens with frequent heavily soiled items

- The best wash results with granule technology
- Great flexibility with 6 programmes
- Unique through-feed machine
- Heat recovery system
- Low operating costs
- Effective washing and high capacity
- HACCP
- Service-friendly



Excellent wash results with granule technology

Wexiödisk's pot dishwashers with plastic granules have a high capacity and clean effectively, giving high levels of hygiene at very low operating costs.

Washing with granules reduces the need for normal preliminary tasks such as soaking and scrubbing. Items are washed with a mixture of water, plastic granules and detergent. Burnt-on food particles are removed quickly and effectively without soaking. Only loose food particles need to be scraped off before washing. A number of unique programme options, including a spin cycle, enable the items to be dried quickly to ensure maximum hygiene.



Fast and effective washing with plastic granules without soaking. Plastic granules part. no. 3-7260. Cleaning scraper part. no. 3-7261.

Unique through loading machine

Together with the loading bench and trolley, the through loading machine forms a system for a simple separation of clean and dirty items. The washing system for through loading includes two cassettes. While the first cassette is being washed the second is prepared. This reduces the time taken to swap the cassettes and increases the effective washing time. This type of washing system, in combination with correct loading of the cassette, increases capacity and creates an efficient and ergonomic flow of dishware in the dishwashing room.

Heat recovery system

The machine is equipped with a heat recovery system, which preheats the cold water used for the final rinse. The system reduces the energy costs considerably. The heat recovery unit also condenses steam during the wash and thus minimizes the heat and humidity in the dishroom. Due to the efficient spinning cycle, only 6 litres of fresh water is used per washing programme.

Low operating costs

The machine's unique spin cycle, combined with the rotation of items during the wash and final rinse cycles, produces excellent washing results and reduces the quantity of rinsing water required. Operating costs are minimized and drying results are considerably improved.

Effective washing and high capacity

The patented dual pump system has two washing tanks: one for water mixed with granules and one for water without any granules. With the dual pump system a reliable granule separation is achieved.

Maximum control of hygiene with HACCP

The built-in HACCP quality system involves a number of critical control points for hygiene. HACCP is a preventive system which ensures that hygiene requirements are met during the washing process. Critical points, such as temperature and water flow, are easily followed and secured by the control system.

Service-friendly

WD-100GR is designed with easy servicing in mind. Most components are easily accessible and service can normally be carried out from the front of the machine.

The position of the electrical cabinet at a convenient working height gives a clear overview of components.

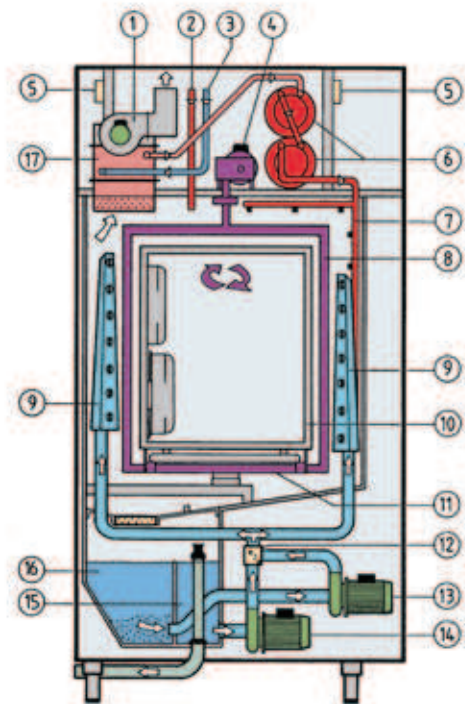

1. Condensing fan
2. Hot water
3. Cold water
4. Rotating table motor
5. Door safety switch
6. Booster heater
7. Final rinsing arm
8. Drive frame
9. Wash arms, 4 pcs
10. Cartridge
11. Rotating table
12. Granule valve
13. Granule washing pump, 2 pcs
14. Washing pump
15. Wash tank
16. Wash tank with granules
17. Heat recovery unit



The WD-100GR is fitted with a text panel to display all information in plain text.

The control panel displays important information such as programme selected, remaining washing time, temperature, alarm, number of washing cycles, etc.

The control panel is also used to test functions in connection with maintenance and servicing.

Great flexibility – simple handling

The machine's six washing programmes with variable washing times make them ideal for a wide variety of items. Programmes with or without plastic granules allow both heavily soiled items and fragile plastic objects to be washed. Programmes without a spin cycle make it possible for items which cannot be secured adequately in the cassette to be washed.

■ **Washing with granules:** During the first stage, the items undergo a powerful treatment: a high pressure wash with a mixture of plastic granules, water and detergent.

■ **Washing without granules:** The items are washed with a mixture of water and detergent. During the chemical washing phase, the granules are rinsed off the items and down into the granule tank.

■ **Spin cycle:** The washing pump stops and the spin cycle starts. The remaining water and granules are removed in the spin cycle and the rotating table returns to normal speed.

■ **Final rinse:** The items are given a final rinse with fresh water heated to 85°C via the booster heater, after which the final spin starts. The spin cycle removes the water from the items and enables fast drying for maximum hygiene.

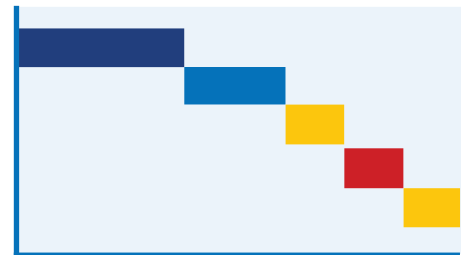

- *Washing with granules*
- *Washing without granules*
- *Spin cycle*
- *Final rinse*



Accessories for WD-100GR

– a selection for different types of dishware



Washing cassette. Part. no. 3-7340
Included in the delivery.



Lid holder. Part. no. 3-7341
Included in the delivery.



Side holder. Part. no. 3-7354
Included in the delivery.

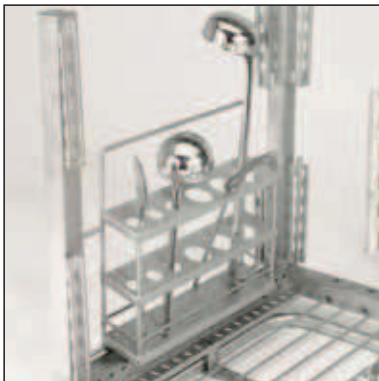

Utensil holder. Part. no. 3-7353
For utensils max 650 mm high.



Wire basket
Part. no. 3-7357



Holder for 1/3-, 1/6- and 1/9-containers
Part. no. 3-7366



ABC container holder.
Part. no. 3-7356

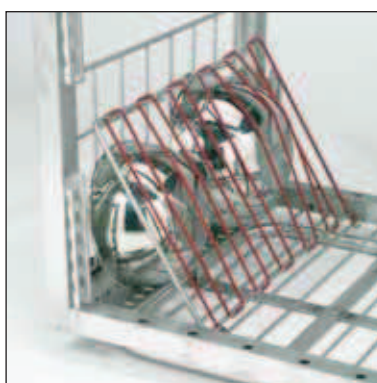

Flexible insert. Part. no. 3-7351
Used together with side holder.

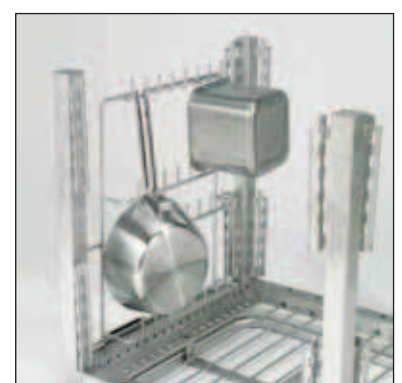

Allround holder
Part. no. 3-7350

The following peripherals and accessories are included as standard (through-loading machine)

Loading table	Part. no. 3-7370	1 pc
Trolley for transportation	Part. no. 3-7362	1 pc
Washing cassette	Part. no. 3-7340	2 pcs
Lid holder	Part. no. 3-7341	6 pcs
Side holder	Part. no. 3-7354	4 pcs
Short guide	Part. no. 3-7343	6 pcs
Long guide	Part. no. 3-7342	2 pcs

The following peripherals and accessories are included as standard (front-loading machine)

Trolley for transportation	Part. no. 3-7362	1 pc
Washing cassette	Part. no. 3-7340	1 pc
Lid holder	Part. no. 3-7341	3 pcs
Side holder	Part. no. 3-7354	4 pcs
Short guide	Part. no. 3-7343	3 pcs
Long guide	Part. no. 3-7342	1 pc

Technical data

Technical data	WD-100GR
Granule pump (kW)	2x2.2
Rinsing pump (kW)	2.2
Motor for the round table (kW)	0.37
Door drive motors (kW)	2x0.09
Booster heater (kW)	9
Heater tank (kW)	12
Condensing fan (kW)	0.12
Condensing fan, capacity (m ³ /h)	300
Heat recovery unit, cooling area (m ²)	11
Tank volume (litres)	145
Weight, machine in operation (kg)	685
Granule volume (litres)	10
Degree of protection (IP)	55

Capacity and operation data	WD-100GR
Total time/washing programme 1** (min) Pr: washing with granules, with spin	5
Total time/washing programme 2** (min) Pr: washing with granules, with spin	8
Total time/washing programme 3** (min) Pr: washing with granules, with spin (can be excluded)	10.3
Total time/washing programme 4** (min) Pr: washing without granules, with spin	2.3
Total time/washing programme 5** (min) Pr: washing without granules, with spin	3.8
Total time/washing programme 6** (min) Pr: washing without granules, with spin (can be excluded)	6.8
Capacity, max (1/1 containers/programme)****	8
Capacity / h, Pr 1 (1/1-containers) incl. handling **** (pc)	90
Capacity / h, Pr 1 (1/2-containers) incl. handling **** (pc)	181
Cold water consumption rinse/programme (litres)*****	4-6
Energy consumption (kWh of connected power)	70-90%
Steam consumption *** (kg/h)	30
Sound level* (dB(A))	70
Max. surface temp. at room temp. 20°C (°C)	35

* Measured 1 metre from the machine

**

Factory setting. The washing time is adjustable.

*** Steam heated machine

Max. capacity depending on the depth of the containers.

***** Applies under ideal conditions and program using spinning.

The water consumption depends on local conditions. An exact adjustment is made during installation.

Connection, electrically heated machine	WD-100GR
Total connected power (kW)	21
Main fuse 400V 3N~ (A)*	35
Max.conn.area 400V 3N~ (L1-L3,N,PE) Cu (mm ²)	35

Connection, steam heated machine 50-250 kPa	WD-100GR
Total conn.power (kW)	4.8
Main fuse 400V 3N~ (A)*	16
Max.conn.area 400V 3N~ (L1-L3, N, PE) Cu (mm ²)	16
Steam connection (internal thread)	R 1"
Connection condensation water (internal thread)	R ½"

* Other voltages on request

Connection water, drain and ventilation	WD-100GR
Water quality, hardness (°dH)	2-7
Cold water connection 5-12°C (internal thread)	R ½"
Hot water conn. 55-70°C (internal thread)	R ½"
Drain connection, PP pipe (ø mm)	50
Water capacity hot water, pressure (kPa)	-
Water capacity hot water, flow (litres/min)	-
Water capacity cold water cooling, min/max pressure (kPa)	-
Water capacity cold water, pressure (kPa)	200
Water capacity cold water, flow (litres/min)	18
Water capacity hot water, min/max pressure (kPa)	100/600
Floor drain, capacity (litres/sec)	3
Ventilation of the machine (m ³ /h)	900

Size and weight for transportation	WD-100GR
Size (packaging included) LxWxH (mm)	1220x1320x2300
Weight (packaging included) (kg)	555

Extra equipment

Machine model		Part. no.
WD-100GR	Through-loaded pot dishwasher, Right/Left	3-7301H
WD-100GR	Through-loaded pot dishwasher, Left/Right	3-7301V
WD-100GR	Front-loaded pot dishwasher	3-7301F
Extra equipment WD-100GR Through-loaded and front-loaded		
Booster pump 230/400V		3-7335
230V/3/50Hz		3-7332
Washing cassette for standard 500 x 500 dishwashing baskets		3-7364
Grid for standard basket 500x 500 mm		3-7365
Extension worktop		3-7371
Holder for lids		3-7341
Flexible insert		3-7351
Holder for GN 1/3, 1/6, 1/9		3-7366
Holder for GN 2/8		3-7368
Holder for pots, bowls, pans		3-7352
All-round holder		3-7350
Utensil holder		3-7353
Side holder		3-7354
Holder for canteen with handles		3-7356
Wire basket for small utensils		3-7357
Short runner		3-7343
Long runner		3-7342
Wall rack for runners		3-7358
Wall rack for lid holder		3-7359
Cutlery holder		3-7367
Wall rack for accessories		3-7360
Connection for external power restriction		3-7339
Connection for external power restriction Sicotronic		3-7339S
External power indication		3-7345
Operating panel right hand side		3-7321
Steam heated design, pressure 50-250 kPa		3-7338Å
Jet spray with 8-metre hose reel		3-7390
Connection line special length		3-7375
Granules 10 kg		3-7260



Trolley for transporting cassettes, part. no. 3-7362.



Loading bench, part. no. 3-7370 with rinsing unit, part. no 3-7390.

Wexiödisk

■ Dimensional drawings

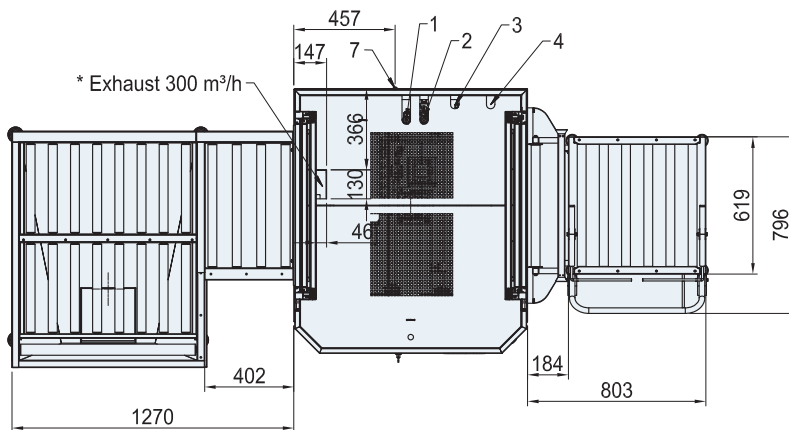
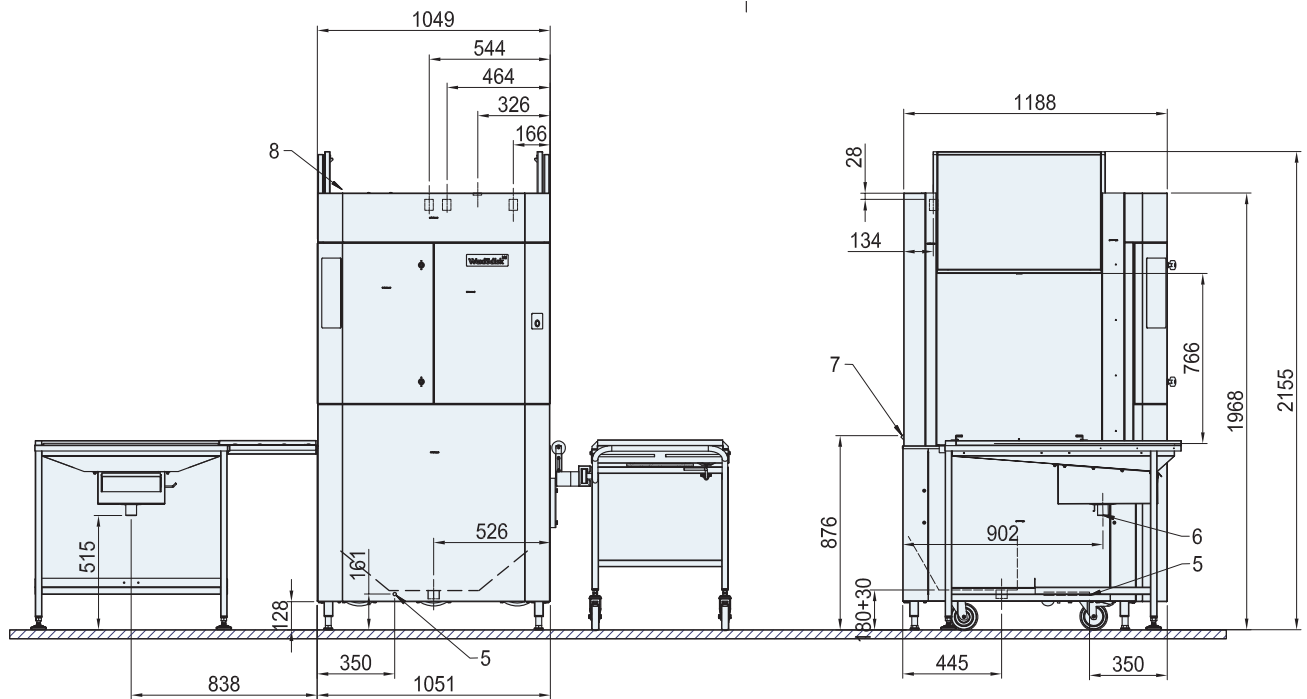

1. Cold water connection 5-12°C, 250-500 kPa, R 3/4" internal thread
2. Hot water connection 55-70°C, 250-500 kPa, R 3/4" internal thread
3. Electrical connection, electrical heated 400V 3N 21kW 35A, steam heated 400V 3N 4,8kW 16A
4. Steam connection 50-250 kPa R1" internal thread, 30 kg/h (steam-heated machine)
5. Condensate water connection 90-95", R1/2" internal thread (steam-heated machine)
6. Drain connection 50 mm
7. Connection for detergent hose
8. General ventilation requirements 900m³/h *10sec at the beginning of the wash cycle and 50 sec starting 10 sec after the final rinse starts.





Telephone: +46 470 77 12 00

Fax: +46 470 237 52

Address: Mårdvägen 4
SE-352 45 Växjö
SWEDEN

E-mail: wexiodisk@wexiodisk.com

Wexiödisk 

www.wexiodisk.com

Lavavajillas de carro

■ WD-18 CW



Wexiödisk 

www.wexiodisk.com



Nuestra historia: ¡lavar a fondo!

Wexiödisk, desde 1972

La empresa sueca Wexiödisk fue fundada en 1972 y, desde sus comienzos, ha centrado sus esfuerzos en ofrecer las mejores lavadoras al sector de cocinas industriales. El excelente nivel de calidad y las innovaciones han generado rápidamente éxitos de ventas, incluso fuera de Suecia.

Calidad

Desde el comienzo, nuestra ambición siempre ha sido lograr que todos nuestros clientes estén satisfechos. Por eso, hemos centrado nuestros esfuerzos en ofrecer seguridad de funcionamiento, costes de funcionamiento reducidos y un buen entorno laboral en lugar de un precio de compra bajo, o sea un enfoque temprano en el coste del ciclo de vida (Life Cycle Cost). Proporcionar un resultado de lavado excelente ha sido siempre algo indiscutible.

Socios

Nuestros socios, que distribuyen, venden y realizan el mantenimiento de nuestros productos, han sido seleccionados minuciosamente. Tenemos un diálogo cercano, les ofrecemos soporte de productos y formación, y juntos nos aseguramos de cumplir con las expectativas del cliente. En la actualidad, Wexiödisk es líder del mercado escandinavo con una red de distribuidores en Europa, pero también en Japón y Australia, entre otros. En los últimos años, Wexiödisk ha obtenido proyectos prestigiosos en el sector de servicios de comidas de aviones, que es una clientela sumamente exigente.

Productos

Seguiremos apostando fuerte al desarrollo de productos para conservar y desarrollar los valores del cliente a través de una gama de productos competitiva y técnicamente avanzada. Para ello, contamos con personal bien formado y herramientas técnicas modernas. Una producción completa, desde el maquinado de la chapa hasta el funcionamiento de prueba, equipada con máquinas de taller automáticas y robots, garantiza un alto grado de calidad y disponibilidad.

Consideración medioambiental

Los lavavajillas son máquinas que consumen grandes cantidades de energía, agua y productos químicos. Por esa razón, Wexiödisk se concentra desde hace algunos años cada vez más en el aspecto ambiental, lo que ha llevado al desarrollo de varios productos nuevos y exclusivos. ICS+ y DUPLUS se denominan algunos principios patentados que ofrecen una reducción extraordinaria del impacto ambiental y costes de funcionamiento considerablemente más bajos.

La empresa

Wexiödisk está situada en Växjö, en el sur de Suecia. Contamos con una superficie edificada de aproximadamente 11.000 m². Allí trabajan alrededor de 175 personas.

Nuestro objetivo

¡Que cada instalación se convierta en una buena referencia!

Ahora, lavar la vajilla es un auténtico placer



WD-18CW Lavavajillas de carro

El lavavajillas de carro WD-18CW ha sido diseñado para responder a los elevados requisitos industriales de clientes en el sector de cocinas de aviones.

Los requisitos de máxima higiene, gran capacidad y, al mismo tiempo, costes de funcionamiento reducidos impedían el uso de la tecnología tradicional. El resultado fue una máquina que también es sumamente adecuada para lavar la mayoría de los carros y otros artículos que se utilizan en las cocinas industriales.

En la actualidad, el lavavajillas WD-18CW se utiliza en cocinas de aviones, pero también en hospitales y cocinas centrales de todo el mundo.

■ Gran capacidad

30 – 40 ciclos de lavado/hora.

■ Operación sencilla

Una persona puede operar fácilmente la máquina.

■ Mejor entorno laboral

Bajo nivel acústico y mejor ergonomía.

■ Flexible

Lava muchos tipos de carros y vajilla diferentes.

■ Costes de funcionamiento reducidos

Consumo mínimo de energía y agua.
Sólo 6 litros de agua por ciclo y secado sin calor.

■ Resultados de lavado y secado excelentes

Exclusiva tecnología de lavado con artículos que giran y secado con centrifugado

■ Máquinas adaptadas al cliente

También ofrecemos adaptaciones especiales para clientes con vajilla especial.



Gran capacidad

El lavavajillas de carro WD-18CW tiene gran capacidad y puede realizar hasta 30-40 ciclos de lavado/hora. Existen tres programas de lavado diferentes y un programa normal dura solamente alrededor de 95 segundos. La máquina es amplia y las dimensiones interiores del compartimiento de lavado son 1.070 x 1.030 mm, altura de 1850 mm, lo que significa que pueden lavarse simultáneamente varios carros según el tamaño.

Operación sencilla

Una persona puede operar fácilmente la máquina. Gracias a la apertura automática de las puertas, la alimentación de la máquina es sumamente sencilla. Con sólo oprimir un botón se inicia el programa de lavado y en el display de la máquina aparece el proceso de lavado.



Mejor entorno laboral

Considerando las condiciones de trabajo exigentes que suelen existir en una sala de lavado hemos centrado gran atención en mejorar el entorno laboral. Por ejemplo, no se suministra aire caliente al local de trabajo durante el proceso de secado, lo que confiere un mejor clima interior al tiempo que se reducen los requisitos de ventilación y aire acondicionado.

Además, la máquina tiene un nivel acústico muy bajo.

Si se compara con el lavado manual de carros, el lavavajillas WD-18CW confiere una mejor ergonomía, menor contacto con productos químicos y elimina los riesgos de accidentes dado que no hay necesidad de lavar y secar carros en el local de trabajo.

Flexible y compacto

El WD-18CW es apto para muchos tipos de vajilla y carros de diferentes marcas. Se puede lavar perfectamente artículos grandes, como carros de distribución de comida, carros de inserción, carros de dosificación, carros con estantes, carros de transporte y diferentes tipos de vajilla de lavado intenso. Véanse algunos ejemplos en la página siguiente. Asimismo, la máquina ocupa poco espacio, apenas 4,5 m² de superficie del suelo.

Costes de funcionamiento bajos - sólo 6 litros de agua por ciclo

A través de muchos años de trabajo de desarrollo, hemos logrado alcanzar el equilibrio entre la máxima prestación de la máquina y un mínimo impacto ambiental. El lavavajillas WD-18CW consume solamente 6 litros de agua limpia por ciclo de lavado. Por lo tanto, el consumo de electricidad y productos químicos es sumamente bajo. Puede compararse con el lavado manual de carros, la alternativa más común al lavavajillas de carros, que consume 20–50 litros de agua caliente por carro, más el detergente. Otro ahorro se obtiene utilizando el aire de ventilación de salida para calentar el agua fría de entrada.

Resultados de lavado y secado excelentes

Con una tecnología única se logran resultados de lavado y secado excelentes en muy poco tiempo. La combinación de brazos de lavado fijos con artículos que giran permite lavar las esquinas menos accesibles de los artículos.

El secado se realiza mediante un centrifugado eficaz y garantiza que no queden restos de agua en lugares escondidos, por ejemplo detrás de mangos, puertas, bisagras, etc. Durante el secado no se suministra calor. En cambio, los artículos se secan mediante una mayor velocidad de rotación. Además no se requiere ningún suministro adicional de aire caliente.

Máquinas adaptadas al cliente

Como estándar, la máquina se entrega con acondicionamiento interior para diferentes tipos de artículos. Probablemente, los artículos que entran en un círculo de 1.600 mm de diámetro pueden lavarse. También ofrecemos adaptaciones especiales para clientes con artículos de otras medidas.

Supervisión e información

El exclusivo sistema de supervisión WEB Tool está desarrollado para permitir una racionalización del lavado, reducir el impacto ambiental y minimizar los costes de funcionamiento. Con WEB Tool, el lavavajillas se conecta fácilmente a la red y al PC. Un navegador común, por ejemplo Internet Explorer, crea informes y se realiza una supervisión de la información HACCP (por sus siglas en inglés, Análisis de Peligros y Puntos de Control Críticos) del lavavajillas, los costes, el consumo de agua y electricidad, para cumplir los requisitos vigentes de HACCP. Esta función garantiza un resultado de lavado higiénicamente óptimo, lo que se documenta y almacena en la máquina y puede imprimirse si es necesario.

Diferentes modelos de carros

Ejemplos de diferentes tipos de carros y otros artículos que pueden lavarse. Tener en cuenta que los carros y otros tipos de artículos sobre ruedas no requieren bloquearse en su lugar. Gracias a la rotación son presionados firmemente contra el lado interior de la jaula giratoria. ¡Sólo hace falta deslizar los artículos en el interior de la máquina, cerrar la puerta e iniciar el lavado!

Carros de inserción



Carro con estantes



Carros de transporte de comidas



Peso máximo 250 kg.

Carros de transporte



Carros de transporte



Carro tipo mesa



Otros artículos

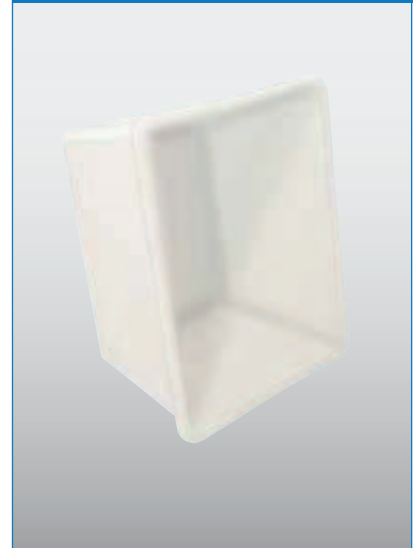

Datos técnicos

Datos técnicos	WD-18CW
Bomba de lavado (kW)	2,2
Bomba de retorno (kW)	1,2
Motor de mesa de rotación (kW)	0,55
Ventilador de condensación (kW)	1,1
Motor de accionamiento de cortinas (kW)	2x0,18
Calentador de paso continuo (kW)	12
Calentamiento del depósito (kW)	36
Recuperación de calor, superficie de refrigeración (m ²)	51
Ventilador de recuperación térmica, caudal (m ³ /hora)	1400
Capacidad del depósito (litros)	200
Peso, máquina funcionando (kg)	1450
Protección (IP)	55

Capacidad y datos de funcionamiento	WD-18CW
Tiempo de lav. total programa 1 (min.) *	1,2
Tiempo de lav. total programa 2 (min.) *	1,6
Tiempo de lav. total programa 3 (min.) *	2,0
Tiempo de lav. total programa 4 (min.) * Sin centrifugado	1,0
Tiempo de lav. total programa 5 (min.) * Sin centrifugado	1,4
Tiempo de lav. total programa 6 (min.) * Sin centrifugado	1,8
Capacidad, máx. (cestas / hora)	50
Tamaño máx. de la vajilla con equipamiento estándar (mm)	Al=1.850 A=1.070 L=1.030
Peso máx. de la vajilla con equipamiento estándar (kg)	250
Consumo de agua de aclarado/programa (litros)	6
Consumo de aire comprimido (litros/min.)	50
Consumo de energía (% de la potencia conectada)	70-90
Consumo de vapor (kg/h)**	90
Temperatura de la superficie con 20°C de temperatura ambiente (°C)	35
Nivel acústico (dB(A)) ***	65

* Ajuste de fábrica. El tiempo de lavado es regulable.

** En máquinas calentadas por vapor.

*** Medido 1 metro al costado de la máquina

Conexión, máquina calentada por electricidad	WD-18CW
Potencia de conexión total (kW)	52,5
Fusible principal 400V 3N~(A)*	80
Superficie de conexión máx. 400V 3N~ (L1-L3,N,PE) Cu (mm ²)	70
Conexión, máquina calentada por vapor 150-250 kPa**	
Potencia de conexión máx. (kW)	4,5
Fusible principal 400V 3N~(A)*	20
Superficie de conexión máx. 400V 3N~(L1-L3, N, PE) Cu (mm ²)	35
Conexión de vapor (rosca interior)	R1 1/4
Conexión de agua de condensación (rosca interior)	R3/4

* Otras tensiones de conexión bajo pedido.

** Otra presión bajo pedido.

Datos técnicos

Conexión de agua, desagüe y ventilación	WD-18CW
Calidad del agua, dureza (°dH)	2 - 7
Conexión de agua caliente 55 - 70 °C (rosca interior)	R3/4
Conexión de agua caliente 5-12 °C (rosca interior)	R3/4
Aire comprimido 600kPa (rosca interior)	R 1/2
Conexión de desagüe, conducto PP (ø mm)	50
Capacidad de agua fría, presión (kPa)	300
Capacidad de agua fría, caudal (l/min.)	30
Capacidad de agua caliente, presión mín./máx. (kPa)	100/600
Sumidero (litros/segundo)	3
Ventilación, máquina (m³/h)	2000

Tamaño y peso para el transporte, máquina dividida estándar**	WD-18CW
Tamaño de máquina completa *(LxAxAI (m))	2,6x2,0x2,75
Peso de máquina completa* (kg)	1350
Tamaño de parte 1*(LxAxAI (m)) **	2,6x2,0x2,25
Tamaño de parte 2*(LxAxAI (m)) **	1,9x2,05x0,8
Peso de parte 1* (kg) **	850
Peso de parte 2* (kg) **	580

* Incluyendo el embalaje.

** Suministro en 2 partes. En partes más pequeñas si es necesario.

Instalaciones alternativas

1. Una sola puerta / modelo con alimentación transversal

La máquina se suministra con una o dos puertas según la disposición actual.

La versión con una puerta se monta en espacios estrechos donde la alimentación de entrada y salida se realizan del mismo lado. Si la disposición permite que WD-18CW mantenga separados el lado limpio y el lado sucio, se colocan dos puertas, o sea una máquina de alimentación transversal.

2. Montaje en el suelo o montaje embutido

La máquina puede instalarse de dos maneras diferentes:

En posición vertical sobre el suelo existente, lo que no impone requisitos especiales al edificio.

En ese caso, la entrega incluye rampas.

Embutida en el suelo. En las instalaciones nuevas, se recomienda colocar la WD-18CW de manera embutida para que la alimentación de entrada y la alimentación de salida queden a la altura del suelo del edificio.

■ Dimensiones – montaje en el suelo

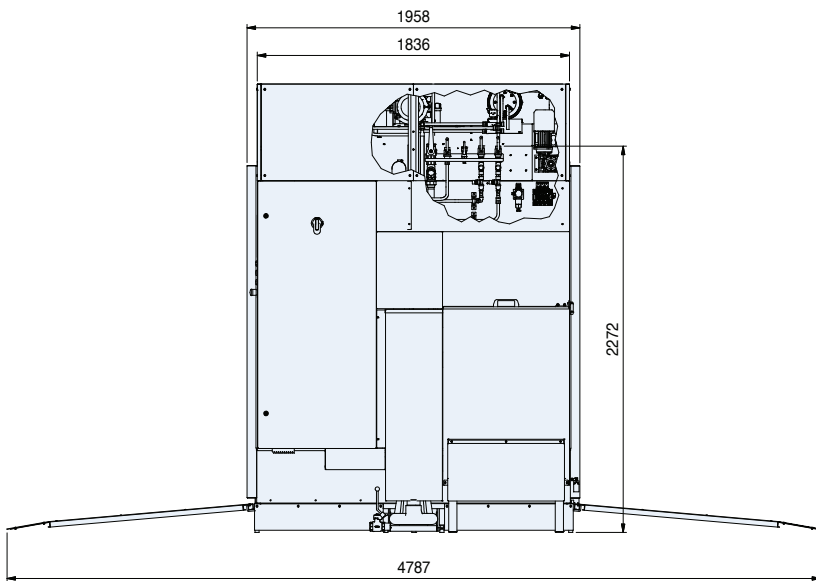

1. Agua caliente DN20, 30 l/min., 300 kPa
2. Agua fría DN20, 30 l/min., 300 kPa
3. Aire comprimido DN15, 600 kPa, 50 l/min.
4. Condensado DN20
5. Vapor DN32, 150-250 kPa, 90 kg/h
6. Conexión eléctrica 52,5 kW (calentamiento eléctrico)
4,5 kW (calentamiento por vapor)
7. Ventilación Ø160 mm, 1400 m³/h (60 s/programa)
8. Desagüe (200 l/min.)

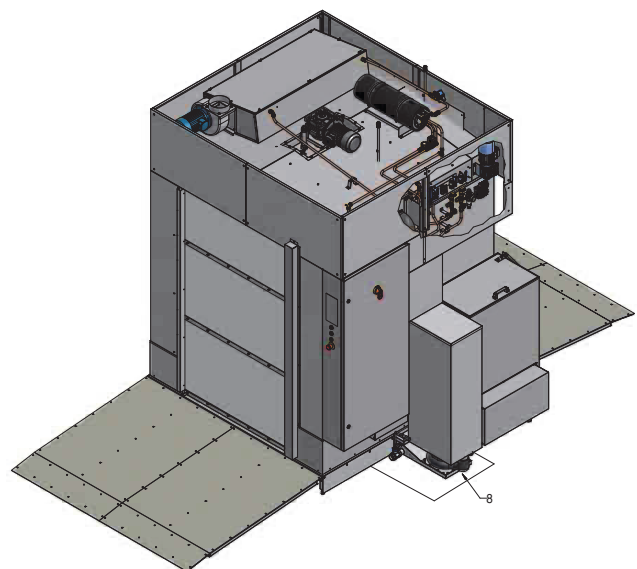
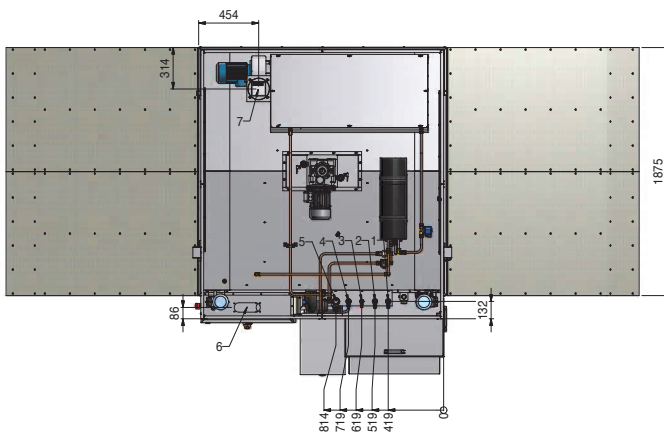
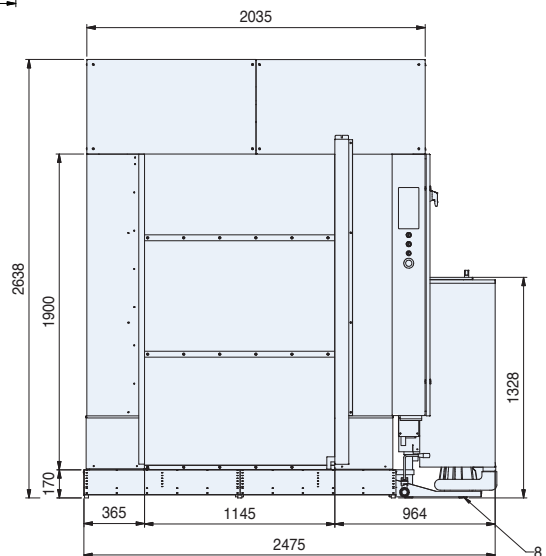

Dimensiones – montaje embutido

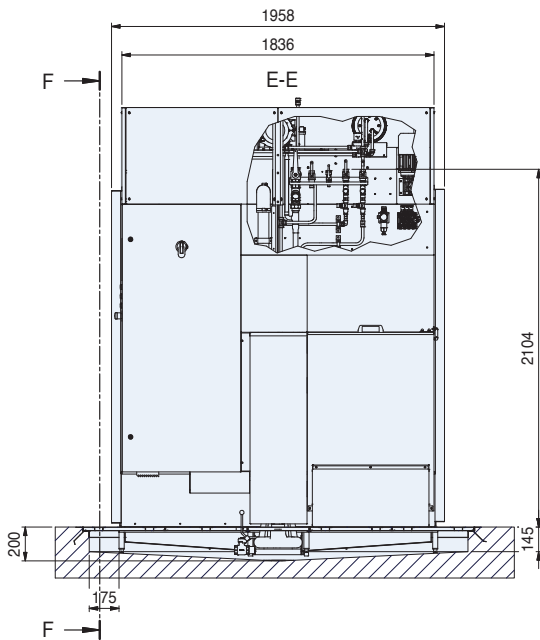

1. Agua caliente DN20, 30 l/min., 300 kPa
2. Agua fría DN20, 30 l/min., 300 kPa
3. Aire comprimido DN15, 600 kPa, 50 l/min.
4. Condensado DN20
5. Vapor DN32, 150-250 kPa, 90 kg/h
6. Conexión eléctrica 52,5 kW (calentamiento eléctrico)
4,5 kW (calentamiento por vapor)
7. Ventilación Ø160mm, 1400 m³/h(60 s/programa)
8. Desagüe (200 l/min.)

Para la instalación embutida en el suelo la entrega incluye un bastidor de embutido y tapaderas. Se requiere un foso en el suelo de 200 mm de profundidad.

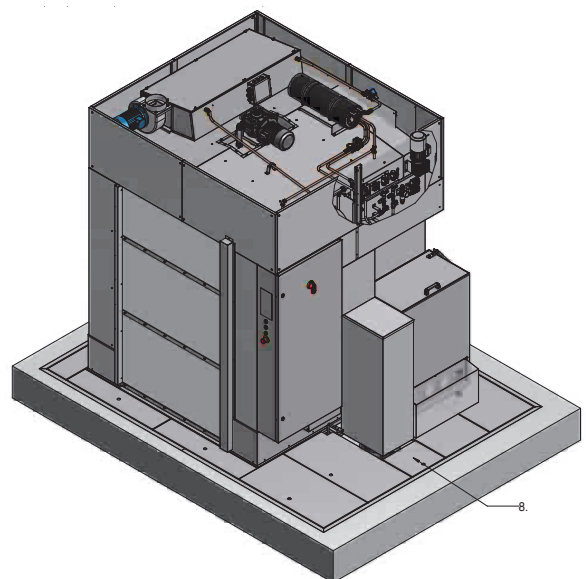
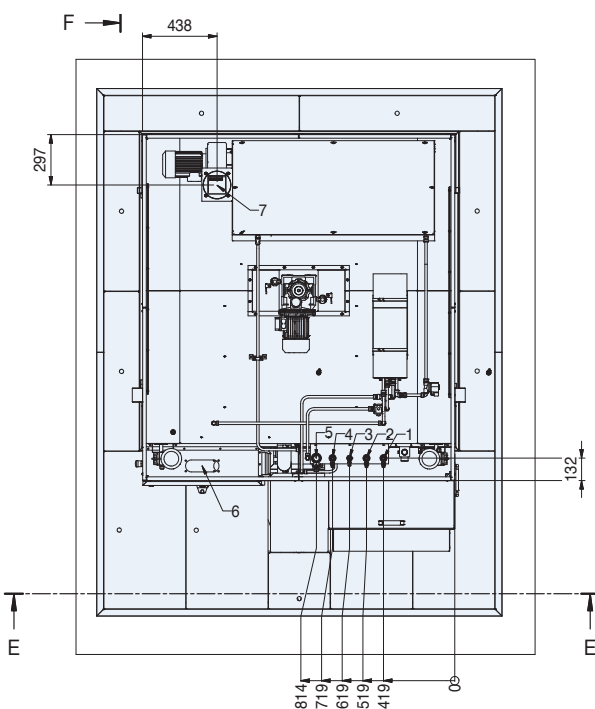
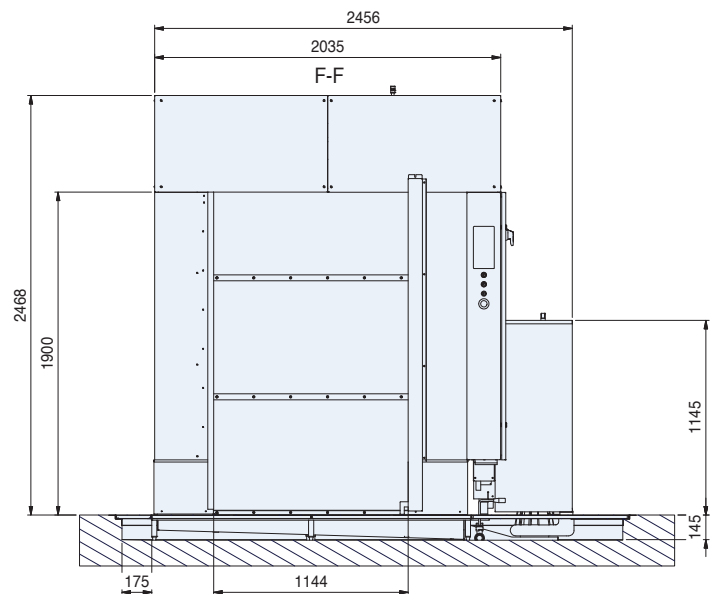

BECAUSE WE DO CARE

Teléfono: +46 470 77 12 00
Fax: +46 470 237 52
Dirección: Mårdvägen 4
SE-352 45 Växjö
SUECIA
E-mail: wexiodisk@wexiodisk.com

Wexiödisk 

www.wexiodisk.com

WD-151E/421E

RACK CONVEYOR DISHWASHER



Wexiödisk 

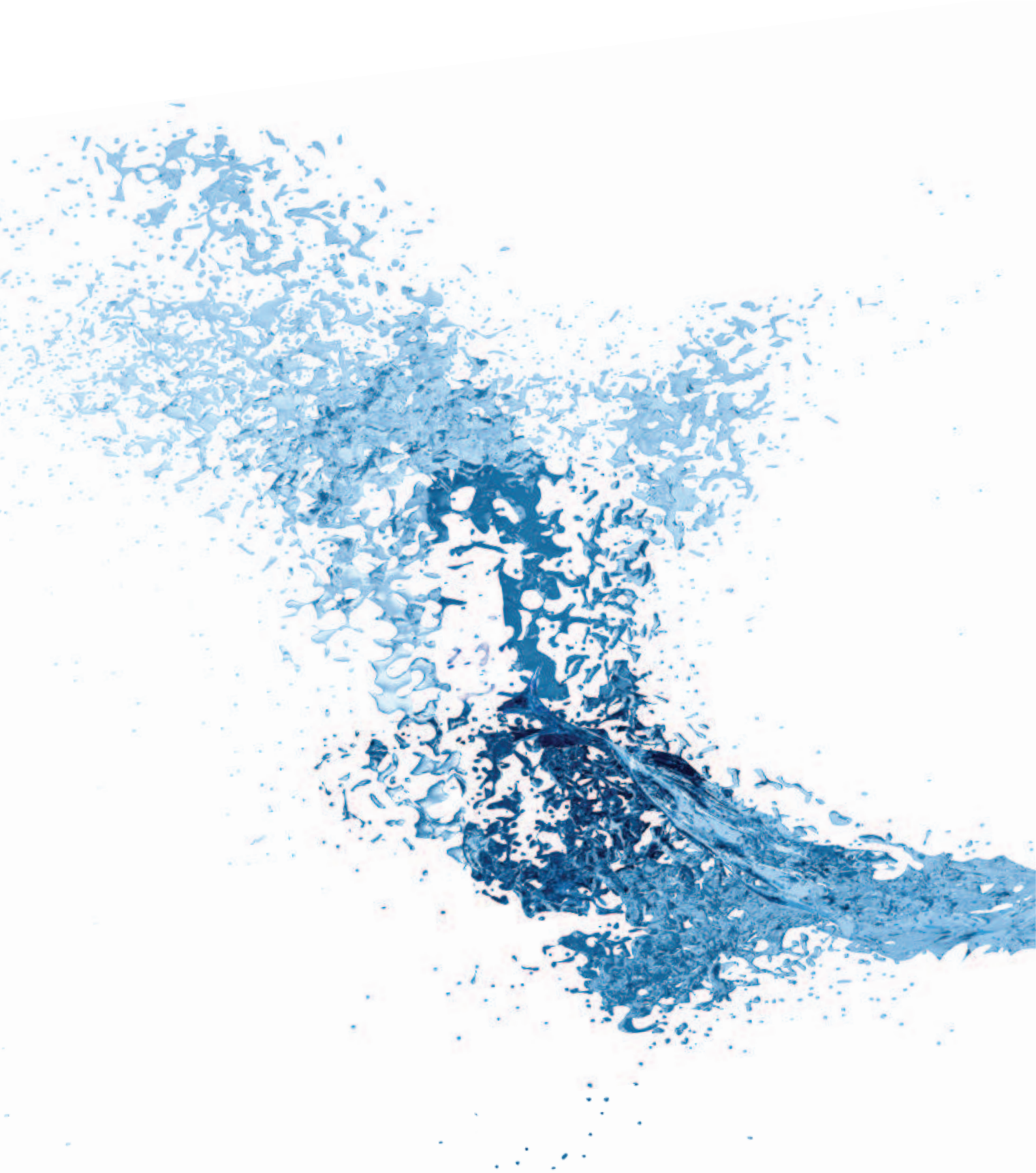

All installations must result in a good reference!

www.wexiodisk.com



One of the most efficient rack conveyor dishwashers on the market

USER-FRIENDLY

During the development of the machines, the emphasis is on ergonomics and ensuring a good working environment. Large, easily opened doors make the inside of the machine easy to access and the washing arms are straightforward to clean. The efficient filters in the washing zones are simple to remove for cleaning. Effective sound and heat isolation helps to provide a good working environment in the dishwashing room. The dishwasher's automatic start/stop function is controlled by the baskets fed into the machine.

FLEXIBLE WASH TIME

By selecting manual operation on the control panel the wash time for a specific basket can be prolonged as long as required. The basket remains in the chemical washing zone until the next basket enters the zone.

REDUCED USE OF RINSING WATER

The majority of rack conveyor dishwashers have at least two programmes or speeds, one slow and one fast. When operating at the slow speed, the dishwasher can use up to double the amount of energy, water and chemicals. Wexiödisk's rack conveyor dishwashers have a flexible feed rate and use only 1.8 litres of rinsing water per basket, regardless of whether or not the machine is operating at full capacity.

HIGH LEVELS OF HYGIENE WITH THE HACCP FUNCTION

Using the HACCP (Hazard Analysis Critical Control Point) system it is possible to designate a number of critical control points for monitoring from a hygiene perspective. The critical control points form part of the machine's control and alarm system for temperature and water flow, which can be displayed on the control panel.

COMPREHENSIVE RANGE OF ACCESSORIES

A selection of accessories is available for our rack conveyor dishwashers to meet every customer's needs.

These include:

Pre-wash zone

WD-PRM60/90 pre-wash machine

Different drying zone options

A web tool with HACCP documentation

Roller tables for the loading and unloading sides of the dishwasher



User-friendly

- Ergonomically designed to provide a good working environment

Low operating costs and a reduced environmental impact

- Low water and energy consumption. Only 1.8 litres of rinsing water per basket, regardless of whether or not the machine is operating at full capacity

Excellent wash results

- Long washing zones with powerful pumps

Monitoring system that provides information about the machine's various functions

- Control panel which displays all the necessary information in text form and stores information about consumption of energy and water

Long service life and easy servicing

- Made entirely of stainless steel, easy access for servicing



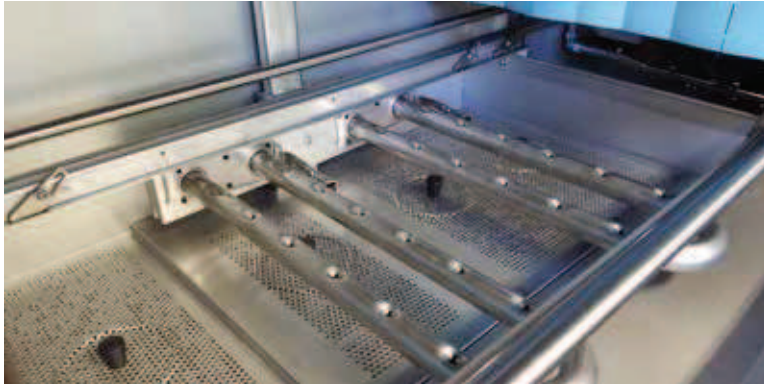

The water is sprayed from above and below, effectively covering the whole basket. The large washing compartment is easy to clean.



All the tanks can be emptied by pressing a lever. The bottom seals and level pipes are closed automatically when the machine is about to fill.

Outstanding performance with high quality components



Self-emptying pumps in the washing and rinsing zones improve hygiene levels.

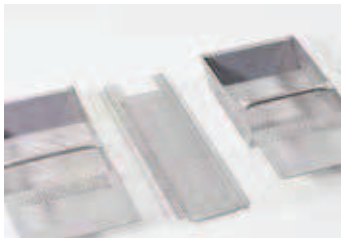

The dishwashers have large, efficient filters and filter baskets that are easy to access and can be emptied very easily.



The doors can be removed with one simple movement, which makes cleaning easier.



Identical washing arms. All the washing arms in the machine are the same and, therefore, they cannot be mixed up. The clip on the side makes it easy to remove each arm for cleaning.



The dishwasher's high ground clearance makes it easy to keep the floor clean. The drain pipe is located in the dishwasher's frame, which also helps with floor cleaning.



The most efficient heat recovery system on the market which is also easy to clean. Regular cleaning will ensure high levels of heat recovery now and in the future.



Detergent dispensing system. The dishwasher has the necessary fittings for a detergent and drying agent dispenser.

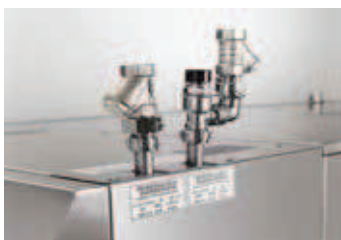

All the water connections are on top of the dishwasher, which means that it has a smooth back panel. Since all the servicing work can be done from the front, the machine can be positioned right up against a wall, which frees up vital space in the dishwashing room.



A double final rinse is standard on all machines, which keeps water consumption to a minimum.



The electrical system is easy to service. The electric cabinet is located at a comfortable working height and all the components are clearly labelled. The system is carefully designed with a logical layout.

"The flexible feed rate allows the operator to choose the contact time for each basket, depending on how soiled the dishes are. The direction of the jets of water constantly changes to produce perfect cleaning results"



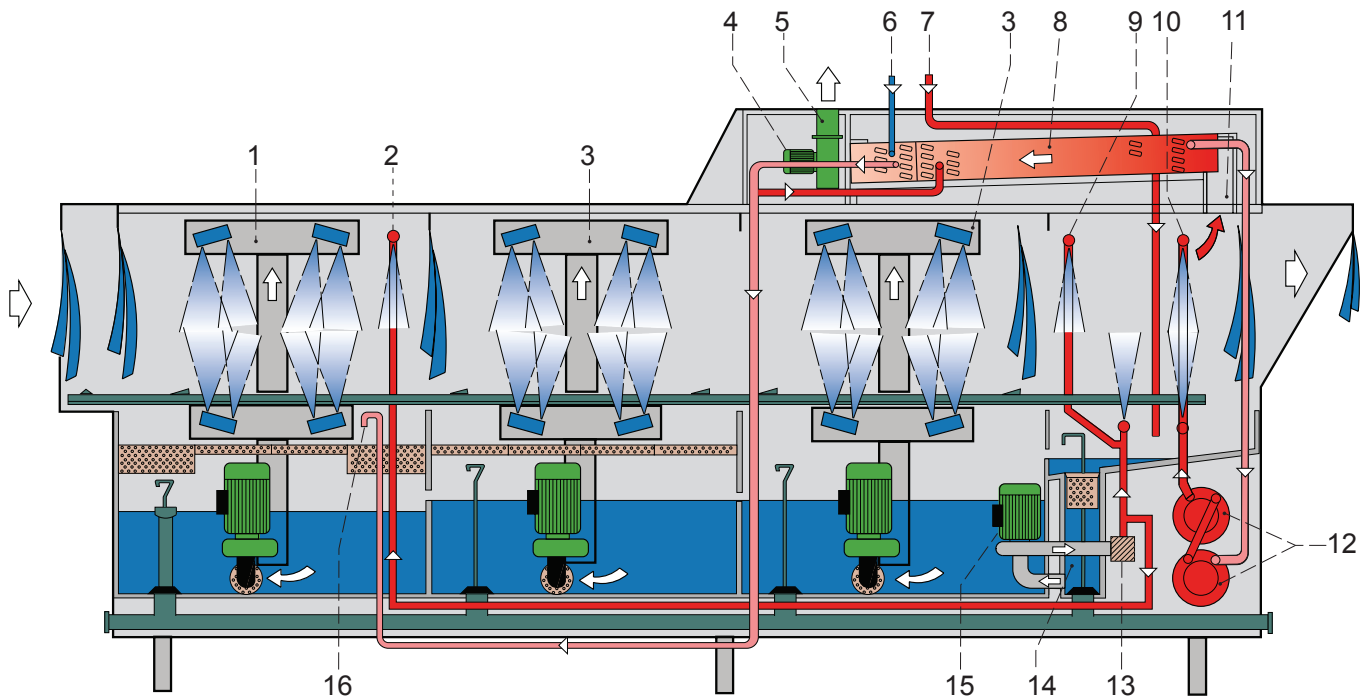

- | | | | |
|----------------------------------|---|--|---|
| 1. Wash ramp, pre-wash zone | 6. Cold water | 10. Final rinse ramp | 15. Pump for recirculating final rinse and intermediate rinse |
| 2. Intermediate rinse ramp | 7. Hot water | 11. Air intake to condensing battery | 16. Cold water for cooling pre-wash zone |
| 3. Wash ramp, chemical wash zone | 8. Condensing battery | 12. Booster heater | |
| 4. Condensing fan | 9. Rinse ramp for recirculating final rinse | 13. Filter for recirculating final rinse | |
| 5. Exhaust from condensing fan | | 14. Tank for recirculating final rinse | |

Get ahead with innovative functionality

PRE-WASH WITHOUT INTERMEDIATE RINSE 1

In the pre-wash, the dishes are sprayed with a weak solution of detergent and water at a temperature of 40°C. Surplus water from the final rinse and chemical wash is reused in this zone.

PRE-WASH WITH INTERMEDIATE RINSE 2

Pre-wash zone with intermediate rinse that rinses off the soiled washing water from the dishes before the baskets leave the zone. As a result, the water used in the chemical wash does not become as soiled. Therefore, the dishwasher can be operated for a longer period without changing the water in the chemical wash tank. This reduces the amount of water and detergent used.

CHEMICAL WASH 3

During the chemical wash, the dishes are washed with water at a temperature of 60°C. The water must be above 50°C to dissolve grease effectively and detergent works best at around 60°C.

DOUBLE FINAL RINSE 4

The double final rinse gives the best possible rinse results and also reduces the amount of water used in the final rinse. Dishes are first rinsed with recycled water and then with fresh water at a temperature of 85°C. Around 25% of the surplus water from the zone is reused in the chemical wash tank. The remaining 75% goes to the pre-wash (WD-211E) and to the intermediate rinse (WD-241E-421E).

INSULATION REDUCES NOISE LEVELS

Wexiödisk's rack conveyor dishwashers are made entirely of stainless steel. They come with heat and noise insulation as standard. The dishwashers are designed with double steel panels and to reduce noise levels even further, all the panels are fitted with noise insulating material.

HEAT RECOVERY SYSTEM

The hot, water-saturated air (11) produced by the machine is sucked through the condensing battery (8) where its energy is transferred to the incoming cold water (6). The cooled air is then blown out into the room (5). The incoming cold water is heated to around 50°C in the condensing battery. The water then flows through the two booster heaters (12) which raise its temperature to around 85°C. After this, it is used in the final rinse (10). The hot water from the final rinse (10) is collected in a tank (14). The pump (15) pumps some of the water to the recirculating final rinse (9) and some to the intermediate rinse (2).

RESULTS

Approximately up to 19kW of energy is recovered. The dishwasher does not need a ventilation connection.



DISHWASHER MODELS



WD-151E



WD-211E



WD-241E



WD-331E



Zone	Zone length in mm
WD-151E	
Loading hood	170
3 Chemical wash	900
4 Double final rinse	585
Total length	1655 *
WD-211E	
Loading hood	170
1 Pre-wash without intermediate rinse	600
3 Chemical wash	900
4 Double final rinse	585
Total length	2255 *
WD-241E	
Loading hood	170
2 Pre-wash with intermediate rinse	900
3 Chemical wash	900
4 Double final rinse	585
Total length	2555 *
WD-331E	
Loading hood	170
2 Pre-wash with intermediate rinse	900
3 Chemical wash	1800
4 Double final rinse	585
Total length	3455 *
WD-421E	
Loading hood	170
2 Pre-wash with intermediate rinse	900
3 Chemical wash	2700
4 Double final rinse	585
Total length	4355 *

* Installation dimensions at bench height. The steam hood over the unloading area adds a further 280 mm. (see the dimension drawing)



PRE-RINSE AND DRYING ZONES

PRE-RINSE ZONE

If a pre-rinse zone is connected to the dishwasher, no more manual washing of dishes is needed. The pre-rinse zone saves both water and effort. In the pre-rinse zone designed for use with the WD-151E, the dirty items are first sprayed with cold water from above and below and then with recirculated final rinse water from below. A pre-rinse zone that reuses the pre-wash water is available for the WD-211E-421E dishwashers. The filter drawer is pulled out from the front and can be emptied without stopping the dishwasher.

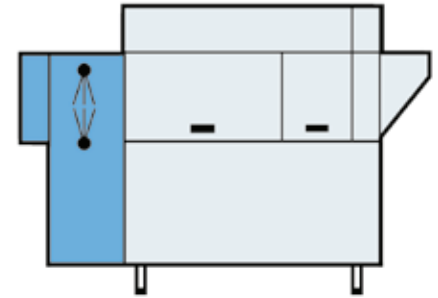

Pre-wash zone

PRE-RINSE ZONE WD-151E-421E	ZONE LENGTH MM
Loading direction R-L	400
Loading direction L-R	400

DRYING ZONES

Our dishwashers can be equipped with T60, T80, T60F or T90 drying zones. A powerful fan blows warm air over the washed items. The drying zones are primarily for use with items such as plastic trays which do not accumulate large amounts of heat. The distribution regulator on the fan targets the warm air effectively to keep energy costs low. Part of the energy is used by a condensing battery which heats up the incoming cold water. The T60, T80 and T60F have a heat output of 3 kW, while the figure for the T90 is 2x3 kW. The T80 is intended for use with dishwashers which have a motor-powered turn track.



Drying zone WD-T60



Drying zone hood WD-T80 for turn track



Drying zone WD-T90



Drying zone hood WD-T60F, free-standing

PART	POWER (KW)	MAIN FUSE 400V 3N~(A)	INSTALLED LENGTH (MM)
Drying zone WD-T60 + WD-151E	35,9	63	600 + 1655
Drying zone WD-T60 + WD-211E	43,4	80	600 + 2255
Drying zone WD-T60 + WD-241E	43,4	80	600 + 2555
Drying zone WD-T60 + WD-311E	50,9	80	600 + 3455
Drying zone WD-T60 + WD-421E	61,4	100	600 + 4355
Drying zone WD-T90 + WD-151E	39,2	63	900 + 1655
Drying zone WD-T90 + WD-211E	46,7	80	900 + 2255
Drying zone WD-T90 + WD-241E	46,7	80	900 + 2555
Drying zone WD-T90 + WD-311E	54,2	80	900 + 3455
Drying zone WD-T90 + WD-421E	64,7	100	900 + 4355
Drying zone hood WD-T80 for turn track + WD-151E	35,9	63	820 + 1655
Drying zone hood WD-T80 for turn track + WD-211E	43,4	80	820 + 2255
Drying zone hood WD-T80 for turn track + WD-241E	43,4	80	820 + 2555
Drying zone hood WD-T80 for turn track + WD-311E	50,9	80	820 + 3455
Drying zone hood WD-T80 for turn track + WD-421E	61,4	100	820 + 4355
Drying zone hood WD-T60F free-standing + WD-151E	35,9	63	600
Drying zone hood WD-T60F free-standing + WD-211E	43,4	80	600
Drying zone hood WD-T60F free-standing + WD-241E	43,4	80	600
Drying zone hood WD-T60F free-standing + WD-311E	50,9	80	600
Drying zone hood WD-T60F free-standing + WD-421E	61,4	100	600



ACCESSORIES

PRE-RINSE MODELS FOR DIFFERENT DISHWASHING ROOM LAYOUTS

A PRM-unit rinses and soaks soiled items and reduces the water consumption. It replaces the repetitive manual pre-rinsing movement that can lead to occupational injuries.

There are two versions of pre-rinse machines:

– PRM 60 for straight installation designed for bar feeding or chain conveyor. The bar fed PRM-60 can be used for manual feeding and together with Wexiödisk's corner loading unit.

– PRM 90 for corner installation with chain conveyor.

The PRM-models are easy to clean with removable doors and wash arms.

All service work is carried out from the front of the machine.



WD-C 90/180 90° or 180° motor-powered turn track

Motor-powered turn track made entirely from stainless steel. Frame made from 30x30 mm square stainless steel tubing with adjustable feet. Suitable for all 50x50 cm washing baskets. The baskets are loaded using a plastic drive chain. Equipped with an emergency stop. The turn track is connected to the machine's unloading side, either directly to the machine or to a straight section placed between the machine and the track. The turn track can also be placed on the loading side.



CORNER LOADING UNIT

The corner loading unit is ideal for loading dishwashers in smaller spaces. It is connected to the machine's feeder and does not require an extra motor. Corner loading units are available for both right and left-loading machines. The frame is made from stainless steel and fitted with adjustable feet. Standard length 630 mm. Special lengths 630 - 2785 mm.



WD-BF 90/180 90° or 180° bar-fed turn track

The turn track is made from stainless steel and fitted with plastic stopper hooks. It is driven by the machine's feeder via a feeder bar. No additional motor is needed. The frame is made from square tubing and fitted with adjustable plastic feet. The turn track is connected to the machine's unloading side, either directly to the machine or to a straight section placed between the machine and the track. Turn track length: 780 mm. Straight section length: 260 - 2750 mm.

ROLLER TABLE

The roller table is designed to be connected directly to a dishwasher or a turn track. The table is made entirely of stainless steel and has a frame made of sturdy square tubing. It has a sloping base and a drain connection which can be connected to the floor drain or the turn track. The baskets are moved on durable plastic rollers with robust bearings. The table is available in a fixed version or a pivoting version with locking castors. It can also be fitted with different types of shelves and, if necessary, a limit switch. For more information on lengths and designs, see the price list.





CONNECTION TO ROLLER TABLE OR BENCH

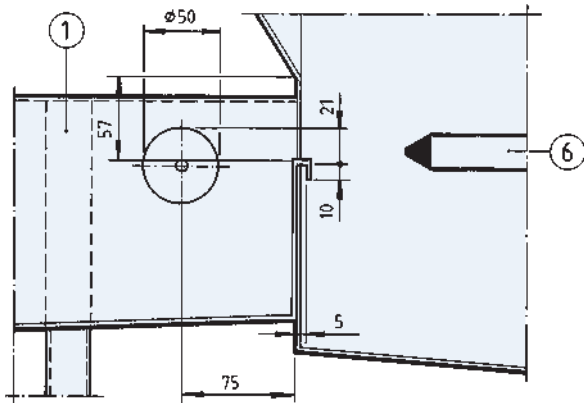
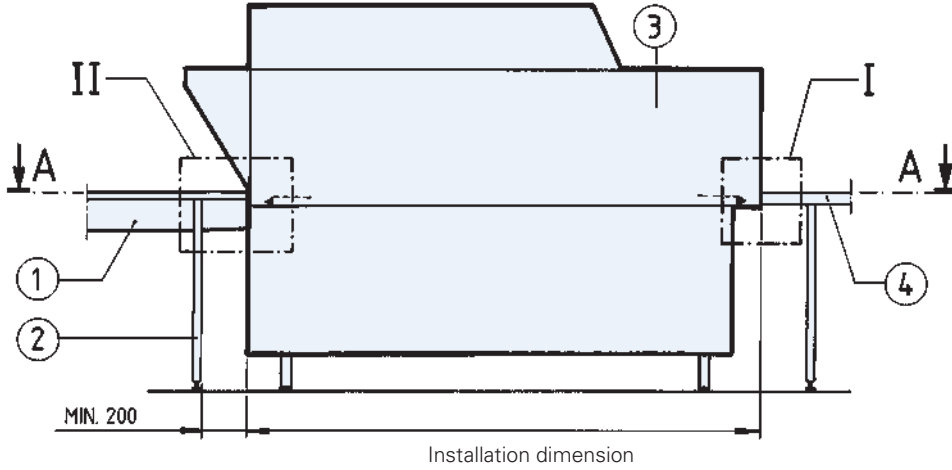

Connection to roller table (II)

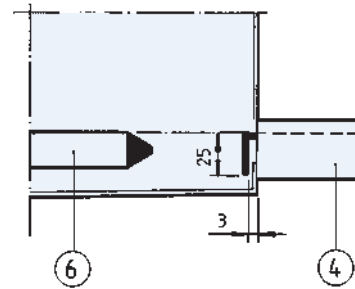

Connection to bench (I)

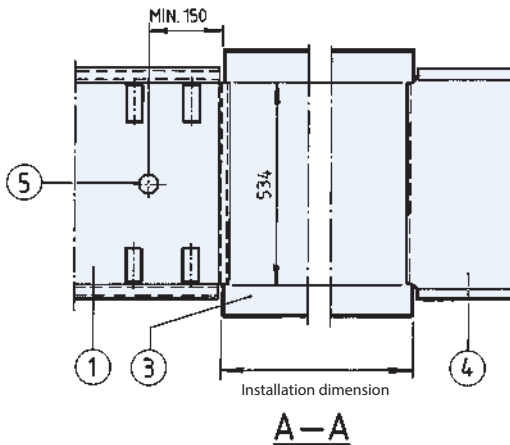

1. Roller table
2. Leg
3. Dishwasher
4. Bench
5. Drain
6. Loading cradle



DIMENSION DRAWINGS

Rack conveyor dishwasher

1. Electrical connection
2. Cold water connection/filter
3. Hot water connection/filter
4. Drain connection
5. Steam connection
6. Condensation connection
7. Floor drain
8. Exhaust steam, condensing unit
9. Alternative electrical connection
10. Alternative cold water connection
11. Alternative hot water connection
12. Alternative drain connection
13. Non-return valve
14. Vacuum valve
15. Water outlet for detergent dispenser
16. Main switch
17. Servicing area

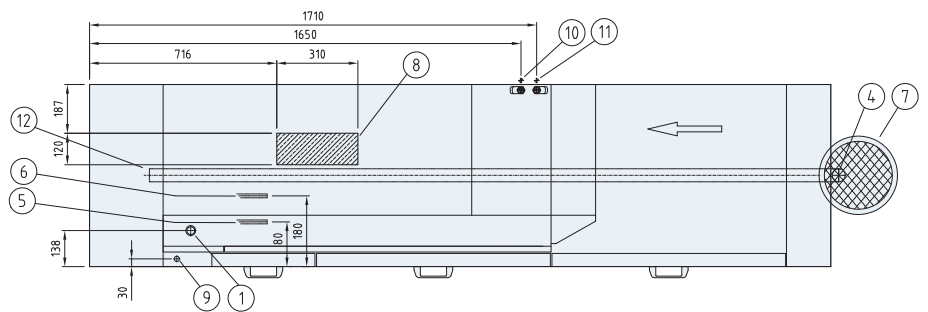
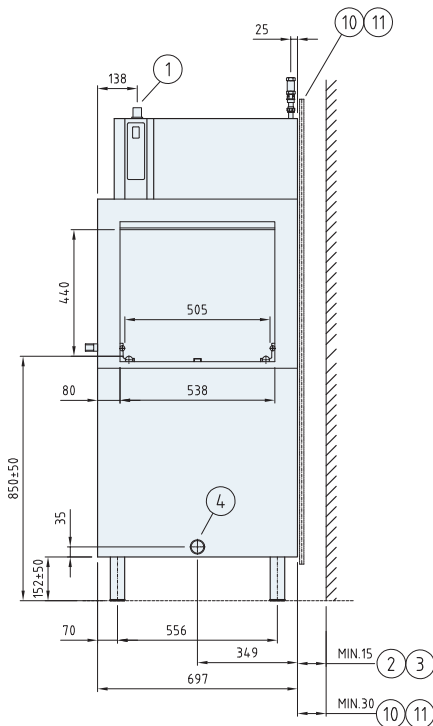
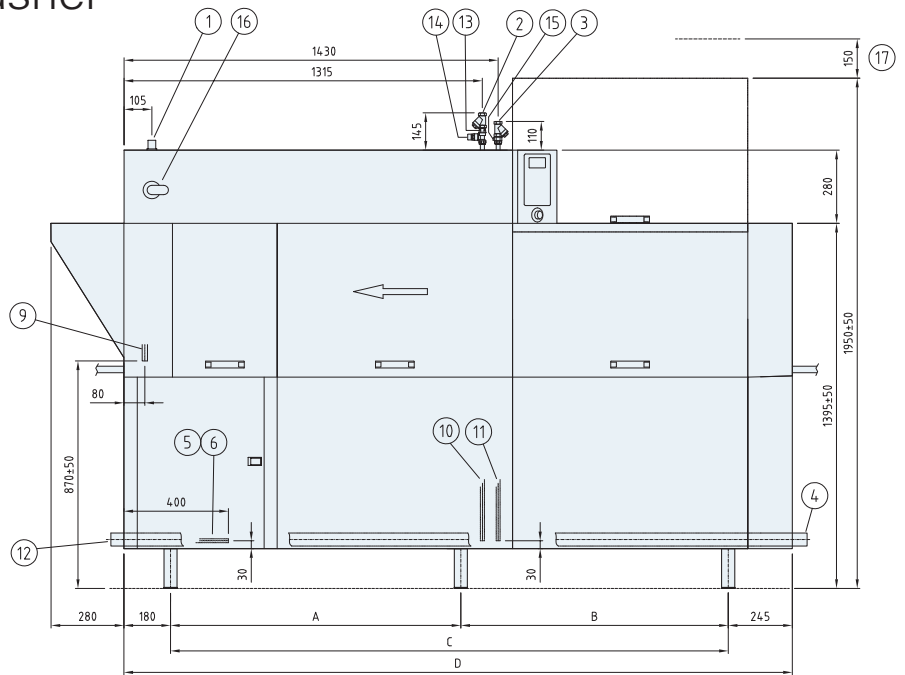

Dimension table

	WD-151E	WD-211E	WD-241E	WD-331E	WD-421E
A	--	--	--	1360	2260
B	--	--	--	1670	1670
C	1230	1830	2130	3030	3930
D*	1655	2255	2555	3455	4355

* Installation dimensions at bench height



TECHNICAL DATA FOR WD-151E/421E

CAPACITY AND OPERATING DATA	WD-151E	WD-211E	WD-241E	WD-331E	WD-421E
Capacity normal wash (baskets/h)	70-150*	100-200*	110-210*	150-230*	150-230*
Capacity according to DIN 10510 (baskets/h)	80	120	140	190	245
Cold water consumption, final rinse normal (litres/basket)	1.8	1.8	1.8	1.8	1.8
Energy consumption (% of connected power)	70-90%	70-90%	70-90%	70-90%	70-90%
Steam consumption** (kg/h)	50	60	60	70	75
Environmental temperature at 20°C room temperature (°C)	35	35	35	35	35
Sound level*** (dB(A))	68	68	68	68	68

* Maximum capacity 240 baskets/h.

** For steam-heated dishwasher

*** Measured 1 metre from the side of the machine

TECHNICAL DATA	WD-151E	WD-211E	WD-241E	WD-331E	WD-421E
Pump, pre-wash (kW)	-	1.5	1.5	1.5	1.5
Pump, chemical wash 1 (kW)	1.5	1.5	1.5	1.5	1.5
Pump, chemical wash 2 (kW)	-	-	-	1.5	1.5
Pump, chemical wash 3 (kW)	-	-	-	-	1.5
Pump, recirculating final rinse (kW)	0.11	0.11	0.11	0.11	0.11
Fan, heat recovery (kW)	0.12	0.12	0.12	0.12	0.12
Motor, feeder (kW)	0.12	0.12	0.12	0.12	0.12
Booster heater 1 (kW)	9	12	12	12	12
Booster heater 2 (kW)	9	12	12	12	12
Heater, chemical wash 1 (kW)	12	12	12	9	9
Heater, chemical wash 2 (kW)	-	-	-	9	9
Heater, chemical wash 3 (kW)	-	-	-	-	9
Heat recovery unit, cooling area (m ²)	25	25	25	25	25
Fan heat recovery, capacity (m ³ /h)	100	100	100	100	100
Tank volume, pre-wash tank (litres)	-	51	77	77	77
Tank volume, wash tank 1 (litres)	100	100	100	100	100
Tank volume, wash tank 2 (litres)	-	-	-	100	100
Tank volume, wash tank 3 (litres)	-	-	-	-	100
Tank volume, final rinse tank (litres)	6	6	6	6	6
Weight, dishwasher in operation (kg)	490	625	655	900	1020
Degree of protection (IP)	55	55	55	55	55

CONNECTION, ELECTRICALLY HEATED DISHWASHER	WD-151E	WD-211E	WD-241E	WD-331E	WD-421E
Total connected power (kW)	32.6	40.1	40.1	47.6	58.1
Main fuse 400V 3N~(A)*	50	63	63	80	100
Max. connection area 400V 3N~(L1-L3, N, PE) Cu (mm ²)	35	35	35	35	35

* Other voltages on request

CONNECTION, STEAM-HEATED DISHWASHER 150-250 kPa*	WD-151E	WD-211E	WD-241E	WD-331E	WD-421E
Total connected power (kW)	1.85	3.4	3.4	4.85	6.0
Main fuse 400V 3N~(A)	16	20	20	20	20
Max. connection area 400V 3N~(L1-L3, N, PE) Cu (mm ²)	25	25	25	25	25
Steam connection (internal thread)	R ¾"	R ¾"	R ¾"	R 1"	R 1"
Condensation connection (internal thread)	R ½"	R ½"	R ½"	R ½"	R ½"

* Other pressures on request.



TECHNICAL DATA FOR WD-151E/421E

CONNECTION, WATER, DRAIN AND VENTILATION	WD-151E	WD-211E	WD-241E	WD-331E	WD-421E
Water quality, hardness (°dH)	2-7	2-7	2-7	2-7	2-7
Hot water connection 50-70°C (internal thread)	R ½"	R ½"	R ½"	R ½"	R ½"
Cold water connection 5-12°C (internal thread)	R ½"	R ½"	R ½"	R ½"	R ½"
Drain connection, PP pipe (ø mm)	50	50	50	50	50
Water capacity, pressure (kPa)	250-600	250-600	250-600	250-600	250-600
Water capacity, flow (litres/min)	11	11	11	11	11
Floor drain, capacity (litres/sec)	3	3	3	3	3
Ventilation, dishwasher (m³/h)	1000	1200	1200	1400	1600

SIZE AND WEIGHT FOR TRANSPORT, STANDARD DISHWASHER*	WD-151E	WD-211E	WD-241E	WD-331E	WD-421E
Size** (LxWxH (m))	2.1x0.8x2.0	2.7x0.8x2.0	3.0x0.8x2.0	3.9x0.8x2.0	4.8x0.8x2.0
Weight** (kg)	400	510	550	680	790

* Normal delivery in 1 piece, If necessary the machine can be further dismantled

** Packaging included

ACCESSORIES	LENGTH MM	WIDTH MM	HEIGHT MM	CONNECTION
WD-C 90, motor-powered turn track 90° R-L	780	780	870 +/- 25 mm	230/400V, 3N~ 50Hz, 0.12kW
WD-C 90, motor-powered turn track 90° L-R	780	780	870 +/- 25 mm	230/400V, 3N~ 50Hz, 0.12kW
WD-C 180, motor-powered turn track 180° R-L	780	1320	870 +/- 25 mm	230/400V, 3N~ 50Hz, 0.12kW
WD-C 180, motor-powered turn track 180° L-R	780	1320	870 +/- 25 mm	230/400V, 3N~ 50Hz, 0.12kW



Wexiödisk

TELEPHONE: +46 470 77 1200 FAX: +46 470 237 52
ADDRESS: Mårdvägen 4 SE-352 45 Växjö SWEDEN
E-MAIL: wexiodisk@wexiodisk.com WEBB: www.wexiodisk.com

Rack conveyor dishwasher

■ WD ICS+ and PRM



Wexiödisk 

BECAUSE WE DO CARE



Every installation must result in a good reference!

www.wexiodisk.com

WD-ICS+

The new generation of rack conveyor dishwashers for medium size kitchens.



■ ICS+ Rack conveyor dishwasher – with savings of up to 70%!



The operating costs of the ICS+ dishwashers are lower than for any other rack conveyor dishwasher. All measurements taken in laboratories and in the field show that the patented ICS+ system is by far the most intelligent control system for dishwashers.

Wexiödisk ICS+ is a cost-effective investment when considering the operating cost and the entire service life. Apart from the excellent wash results, Wexiödisk's environmentally-friendly dishwasher uses up to two-thirds less detergent than standard rack conveyor dishwashers.

The Wexiödisk ICS+ system is already being used by hundreds of satisfied customers, among others Scandic Hotels, all over Sweden.



Wexiödisk's ICS+ rack conveyor dishwashers use the ingenious control system, ICS+ "Intelligent Control System".

The price in relation to service life – Life cycle cost!

Investing in a dishwasher is not just about its price, it's also a decision determined by the cost for the machine's entire service life. The price of the machine is a mere fraction of this cost.

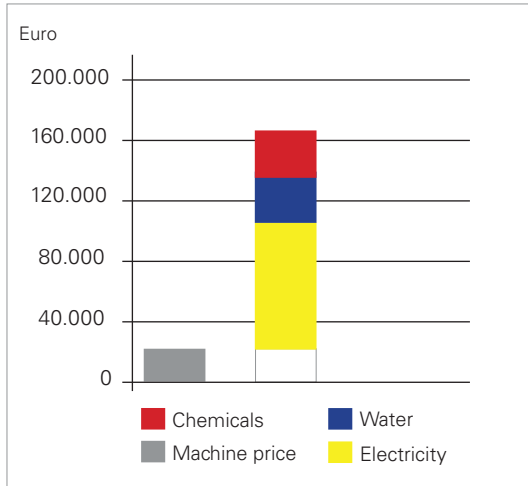

A rack conveyor dishwasher is an investment in which the purchase price makes up only 10-20%, while the operating costs constitute 80-90% of the total costs involved in the machine's service life.

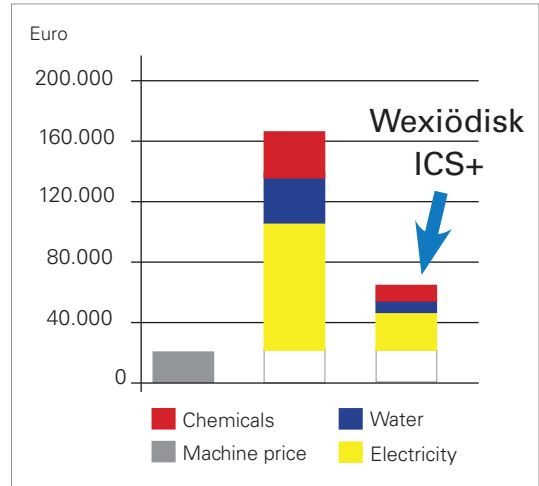

Wexiödisk ICS+ is taking the concept of operating costs to a new dimension. The operating costs of an ICS+ rack conveyor dishwasher are 30-70% lower than for other dishwashers.

Of all kitchen appliances, it is the dishwasher that has the greatest impact on the environment.

Electricity consumption

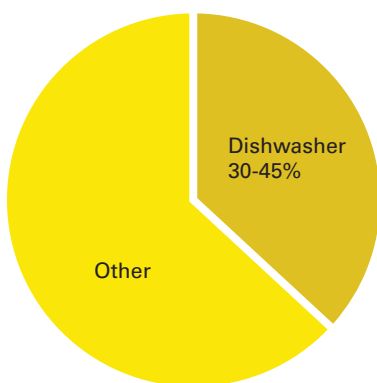

A standard rack conveyor dishwasher accounts for 30-45% of a kitchen's total electricity consumption.

Water consumption

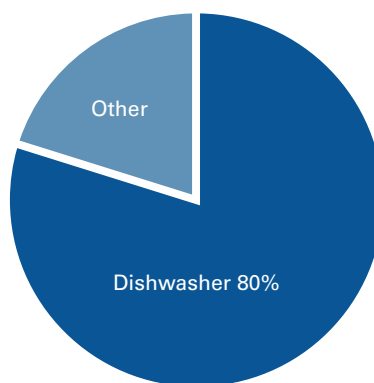

A standard rack conveyor dishwasher accounts for approx. 80% of a kitchen's total water consumption.

Chemical consumption

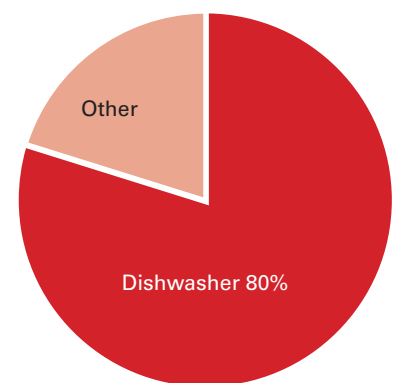

Almost every chemical is water-soluble. Since the dishwasher accounts for approx. 80% of the water consumption, it is also responsible for approx. 80% of a kitchen's total chemical consumption.



■ Wexiödisk ICS+ – our “Intelligent Control System”

- **No empty spaces washed**
 - Empty Space Elimination (ESE).
- **Optimised rinsing water consumption**
 - Constant Rinse Time (CRT) – from 1 litre of rinsing water per basket regardless of capacity.
- **Optimum use of rinsing water**
 - Double Transport System (DTS) with unique double feed.
- **Maximum hygiene – HACCP function**
 - Simple cleaning and good access.
- **Adjustable contact time**
 - Flexible washing programmes for variable items.
- **Double heat recovery**
 - With condensing battery and reuse of rinsing water.

No empty spaces washed – ESE

This unique control system eliminates the empty spaces normally found between the baskets while they are being washed. In a standard dishwasher this empty space can be anything up to 50% of the capacity, something which is not normally considered when specifying water consumption. ICS+ checks the basket feed using a photocell. By not washing the empty spaces, the customer’s costs are considerably reduced.

When the machine is waiting for the next basket, the pumps stop, which significantly reduces the sound level in the dishwashing room.

Optimised rinsing water consumption CRT – from 1 litre of rinsing water per basket regardless of capacity

The majority of rack conveyor machines have at least two speeds: one slow and one fast. When operating at the slow speed, the dishwasher can use up to double the amount of energy, water and chemicals. ICS+ is equipped with CRT, Constant Rinse Time, which ensures that the time and also the amount of water used in the final rinse does not depend upon the speed chosen. Normally only around 1.0 -1.4 litres of rinsing water are used per basket.



Optimum use of rinsing water thanks to our double feed system, DTS

When baskets are being fed through a conventional rack conveyor machine, it is normal for the baskets to remain stationary 50% of the time. This results in high water consumption and unnecessary costs. By having an even speed through the rinsing zone, considerably less water is needed. ICS+ is equipped with DTS – a unique double feed system that feeds the baskets at an even speed to ensure optimum use of the rinsing water.

Maximum hygiene with HACCP function

The HACCP quality system involves a number of critical control points from a hygiene perspective. HACCP is a preventive system which ensures that hygiene requirements are met during the washing process. Critical points, such as temperature and water flow, are easily followed and secured by the control system.

Semi-lateral rinse pipes reduce the consumption.

Semi-lateral rinse pipes with optimized nozzles give a perfect spray pattern which divides the final rinsing water more accurately over the wash ware, giving lowest possible rinsing water consumption.

Adjustable contact time provides flexible washing programmes.

The contact time is one of the main factors necessary for successful washing results. Contact time refers to the time it takes for the baskets to pass from the pre-wash zone with chemicals to the fresh water rinse. The easy-to-use control panel allows the operator to quickly adjust the contact time when needed. This gives the operator full control of the washing result.

Examples of suitable contact times:

Contact time (s)	
40	Rinsing
50	Trays
70	Lightly soiled items
90	Normally soiled items
120	DIN 10510
160	Heavily soiled items



Control panel for WD-243 ICS+

Service-friendly

Wexiödisk's rack conveyor dishwashers are designed with easy servicing in mind. Most components are easily accessible and servicing can normally be carried out from the front of the machine. The position of the electrical cabinet at a convenient working height gives a clear overview of components and offers protection from water when the floor is being cleaned.

PRM – a unique pre-rinse machine

- **Ergonomic** – replaces the repetitive manual pre-rinsing movement that can lead to occupational injuries.
- **Economic** – unique reuse of washing water from the rack conveyor dishwasher provides significant overall water savings.
- **Better wash results** – effective rinsing and soaking of soiled items which at the same time reduces the rinsing water consumption.

Wexiödisk's PRM rinses the items, both from above as well as underneath the basket, with a powerful flow of water, which is impossible to achieve manually. The PRM reuses the overflow water from the rack conveyor machine. The 40°C water contains a small amount of detergent. The efficient rinsing system in the PRM removes food residue and has the same effect as soaking during the time the basket is transported to the dishwasher. This has major benefits, especially when washing dishes with dried-on food.

PRM, together with ICS+, minimises the total amount of water consumed in the dishwashing room, resulting in major cost savings and keeps washing water clean during long wash cycles. This ensures an excellent washing result. A conveyor is usually fitted to a sorting unit, and placed in connection to the machine. The conveyor passes through the PRM and goes on to the dishwasher. The operator can easily and efficiently sort the soiled items, as no manual basket feed or pre-rinse is required.



By reusing the water from the rack conveyor dishwasher, the best possible water and environmental savings are achieved. – A natural investment for the dishwashing room!



Several PRM versions available



*PRM-60, straight chain conveyor feeding
Chain conveyor is not included.
This must be ordered separately.*

Several models for different dishwashing room layouts

There are two versions of the PRM:

- PRM 60 for straight installation designed for bar feeding or chain conveyor. The bar fed PRM-60 can be used for manual feeding and together with Wexiödisk's corner loading unit.
- PRM 90 for corner installation with chain conveyor. The PRM models are easy to clean with removable doors and wash arms. All service work is carried out from the front of the machine.

*PRM-60, bar feeding
Feeder is not included.
This must be ordered separately.*



*PRM-90, corner installation with chain conveyor
Chain conveyor is not included.
This must be ordered separately.*

■ WD ICS+ and PRM
provide many practical
solutions



Thanks to the good clearance height under the machine, it's easy to keep the floor clean. The drain pipe is positioned in the frame of the machine, which also makes it easier to clean the floor.



Double final rinse is standard in all machines, which minimises water consumption.



All the tanks can be emptied using a single lever. Bottom seals and level pipes are closed automatically when the machine is about to fill.



Lightweight wash arms that can be handled and are simple to remove when cleaning.



The doors are removed using a simple handle, which makes cleaning easier.



The most effective heat recovery on the market, and it's also easy to clean. Regular cleaning guarantees the best possible heat recovery, even in the future.

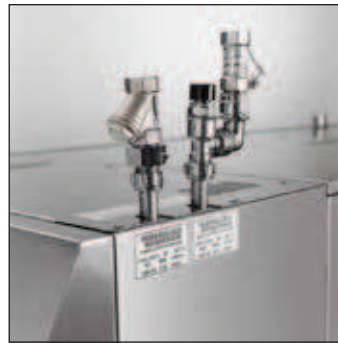

All water connections are on top and the machine has a smooth back. Since all service can be done from the front, the machine can be positioned right up against a wall, which frees up vital space in the dishwashing room.



The PRM has a large and efficient strainer basket, which means it does not need to be emptied as often.



Improved hygiene with selfemptying pumps in wash and rinse zones.



The machines have large filters and strainer baskets that are easy to access when needed. A large strainer basket does not need to be emptied as often.



The efficient spray from above and below covers the entire washing basket. The large washing compartment is easy to clean.

Pre-wash and drying zones

Pre-wash zone

If a pre-wash zone is connected to the dishwasher, no more manual washing of dishes is needed. The pre-wash zone saves both water and effort. In the pre-wash zone designed for use with the WD-153, the dirty items are first sprayed with cold water from above and below and then with recirculated final rinse water from below. A pre-wash zone that reuses the pre-wash water is available for the WD-213–423 dishwashers. The filter drawer is pulled out from the front and can be emptied without stopping the dishwasher.

Pre-wash zone WD-213-423	Zone length mm
Loading direction R-L	400
Loading direction L-R	400

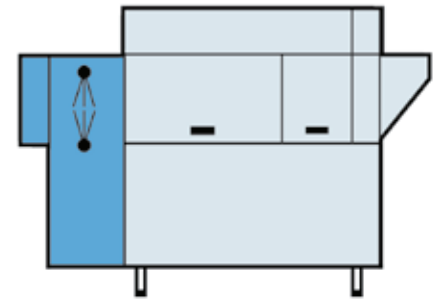

Pre-wash zone

Drying zones

Our dishwashers can be equipped with T60, T80, T60F or T90 drying zones. A powerful fan blows warm air over the washed items. The drying zones are primarily for use with items such as plastic trays which do not accumulate large amounts of heat. The distribution regulator on the fan targets the warm air effectively to keep energy costs low. Part of the energy is used by a condensing battery which heats up the incoming cold water. The T60, T80 and T60F have a heat output of 3 kW, while the figure for the T90 is 2x3 kW. The T80 is intended for use with dishwashers which have a motor-powered turn track.



Drying zone WD-T60



Drying zone hood WD-T80 for turn track



Drying zone WD-T90



Drying zone hood WD-T60F, free-standing

Part	Power (kW)	Main fuse 400V 3N~(A)	Installed length (mm)
Drying zone WD-T60 + WD-153	35,9	63	600 + 1655
Drying zone WD-T60 + WD-213	43,4	80	600 + 2255
Drying zone WD-T60 + WD-243	43,4	80	600 + 2555
Drying zone WD-T60 + WD-333	50,9	80	600 + 3455
Drying zone WD-T60 + WD-423	61,4	100	600 + 4355
Drying zone WD-T90 + WD-153	39,2	63	900 + 1655
Drying zone WD-T90 + WD-213	46,7	80	900 + 2255
Drying zone WD-T90 + WD-243	46,7	80	900 + 2555
Drying zone WD-T90 + WD-333	54,2	80	900 + 3455
Drying zone WD-T90 + WD-423	64,7	100	900 + 4355
Drying zone hood WD-T80 for turn track + WD-153	35,9	63	820 + 1655
Drying zone hood WD-T80 for turn track + WD-213	43,4	80	820 + 2255
Drying zone hood WD-T80 for turn track + WD-243	43,4	80	820 + 2555
Drying zone hood WD-T80 for turn track + WD-333	50,9	80	820 + 3455
Drying zone hood WD-T80 for turn track + WD-423	61,4	100	820 + 4355
Drying zone hood WD-T60F free-standing + WD-153	35,9	63	600
Drying zone hood WD-T60F free-standing + WD-213	43,4	80	600
Drying zone hood WD-T60F free-standing + WD-243	43,4	80	600
Drying zone hood WD-T60F free-standing + WD-333	50,9	80	600
Drying zone hood WD-T60F free-standing + WD-423	61,4	100	600

Accessories

Corner feeder unit

The corner feeder unit is suitable for loading the dishwasher in narrow spaces. It is connected to a feeder and does not require an extra motor. Corner feeder is available for both right and left-loaded machines. The frame is made from stainless steel and fitted with adjustable feet. Standard length 630 mm. Special lengths 631 - 2785 mm.



Powered turn track 90° and 180°

The powered turn track is designed with friction-powered tapered rollers, which make the baskets slide forward easily. The turn track can be used together with all kind of washing baskets and washing machines. Both the top part and the frame are made of stainless steel. Adjustable feet, built-in slip coupling and drain connection DN 32 are standard. The turn track also includes relay switch and internal wiring.

Roller table

Roller table for direct connection to the machine or powered turn track. The construction is made of stainless steel and a solid frame of square tubes. It has an inclined bottom towards the drain. The drainage can either be towards the bottom or a connected curve. The baskets are transported on resistant plastic rollers with bearings. The roller table can be fixed or pivoted with lockable wheels. Shelf and rails for storage of baskets are available. More information of length and variants see price list.



Accessories	Length	Width	Height (mm)	Electrical connection
WD-C 90 Powered turn track 90° R-L	790	790	905 +/- 25 mm	230/400V, 3N~, 50Hz, 0,12kW
WD-C 90 Powered turn track 90° L-R	790	790	905 +/- 25 mm	230/400V, 3N~, 50Hz, 0,12kW
WD-C 180 Powered turn track 180° R-L	790	1340	905 +/- 25 mm	230/400V, 3N~, 50Hz, 0,12kW
WD-C 180 Powered turn track 180° L-R	790	1340	905 +/- 25 mm	230/400V, 3N~, 50Hz, 0,12kW
Corner feeding unit ICS+	630	603	870 +/- 25 mm	
Corner feeding unit ICS+ special	631-2785	603	870 +/- 25 mm	
Other accessories				

WD ICS+ models

Pre-wash zone without intermediate rinse 1

The items are washed with a weak solution of detergent and water at a temperature of approx. 40°C. Surplus water from the final rinse and chemical wash is reused in the zone.

Pre-wash zone with intermediate rinse 2

The intermediate rinse 2, rinses-off the remaining dirty water before entering the chemical wash zone 3. The machine can then be used for a longer period without the water needing to be changed. This saves water and detergent.

Chemical wash zone 3

During the chemical wash zone 3, the goods are washed with washing water at a temperature of 60°C. Grease needs water to be over 50°C to dissolve properly and detergent works best at around 60°C.

Double final rinse zone 4

The double final rinse 4 reduces the amount of fresh water use and gives the best possible rinse results. Items are first rinsed with reused water and then with fresh water at a temperature of 85°C. Approx. 25% of the surplus water from the zone is reused in the chemical wash tank. The remaining 75% is taken to the pre-wash (WD-213) and to the intermediate rinse (WD-243-423 machines).

WD-153 ICS+



WD-213 ICS+

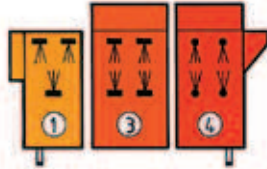

WD-243 ICS+



WD-333 ICS+



WD-423 ICS+



Zone

Zone length in mm

WD-153 ICS+

Steam hood	170
3 Chemical wash	900
4 Double final rinse	585
Total length	1655 *

WD-213 ICS+

Steam hood	170
1 Pre-wash without intermediate rinse	600
3 Chemical wash	900
4 Double final rinse	585
Total length	2255 *

WD-243 ICS+

Steam hood	170
2 Pre-wash with intermediate rinse	900
3 Chemical wash	900
4 Double final rinse	585
Total length	2555 *

WD-333 ICS+

Steam hood	170
2 Pre-wash with intermediate rinse	900
3 Chemical wash	1800
4 Double final rinse	585
Total length	3455 *

WD-423 ICS+

Steam hood	170
2 Pre-wash with intermediate rinse	900
3 Chemical wash	2700
4 Double final rinse	585
Total length	4355 *

* Applies to the installation length at bench height. To include the steam hood (out feed), an additional 280 mm should be added. (see dimensions)

Technical data WD-ICS+

Capacity and operation data	WD-153	WD-213	WD-243	WD-333	WD-423
Capacity (baskets/h)	60-260	80-260	85-260	110-260	135-305
Capacity according to DIN 10510 (baskets/h)	80	120	140	190	245
Max capacity interlocked booster heater (baskets/h)	150	200	200	220	230
Cold water consumption, final rinse normal (litres/baskets) *	1.4	1.3	1.2	1.1	1.0
Cold water consumption, final rinse according to DIN 10510 (litres/h)	112	156	168	209	245

* In combination with PRM the water consumption is further lowered with 0,1 litre

Technical data	WD-153	WD-213	WD-243	WD-333	WD-423
Pump, pre wash (kW)	-	1.5	1.5	1.5	1.5
Pump, chemical wash 1 (kW)	1.5	1.5	1.5	1.5	1.5
Pump, chemical wash 2 (kW)	-	-	-	1.5	1.5
Pump, chemical wash 3 (kW)	-	-	-	-	1.5
Pump, recirculated final rinse (kW)	0.11	0.11	0.11	0.11	0.11
Condensing fan (kW)	0.12	0.12	0.12	0.12	0.12
Motor, feeder (kW)	0.12	0.12	0.12	0.12	0.12
Booster heater 1 (kW)	9*	12*	12*	12*	12*
Booster heater 2 (kW)	9	12	12	12	12
Heater, chemical wash 1 (kW)	12	12	12	9	9
Heater, chemical wash 2 (kW)	-	-	-	9	9
Heater, chemical wash 3 (kW)	-	-	-	-	9
Heat recovery unit, cooling area (m ²)	25	25	25	25	25
Condensing fan, capacity (m ³ /tim)	100	100	100	100	100
Tank volume, pre wash tank (litres)	-	51	77	77	77
Tank volume, wash tank 1 (litres)	100	100	100	100	100
Tank volume, wash tank 2 (litres)	-	-	-	100	100
Tank volume, wash tank 3 (litres)	-	-	-	-	100
Tank volume, final rinse tank (litres)	6	6	6	6	6
Weight, machine in operation (kg)	490	625	655	900	1020
Degree of protection (IP)	55	55	55	55	55
Max. surface temp. at room temp. 20°C (°C)	35	35	35	35	35
Sound level**(dB(A))	68	68	68	68	68

* Interlocked if needed, see capacity

** Measured 1 metre from the machine

Connection, electrically heated machine	WD-153	WD-213	WD-243	WD-333	WD-423
Total connected power (kW) interlocked booster heater (kW)*	23.6	28.1	28.1	35.6	46.1
Total connected power (kW)	32.6	40.1	40.1	47.6	58.1
Main fuse 400V 3N~ (A)*	50	63	63	80	100
Max.conn.area 400V** 3N~ (L1-L3,N,PE) Cu (mm ²)	35	35	35	35	35

* See capacity

** Other voltages on request

Connection, steam heated machine 150-250 kPa*	WD-153	WD-213	WD-243	WD-333	WD-423
Total conn.power (kW)	1.9	3.4	3.4	4.5	6.0
Main fuse 400V 3N~ (A)	16	20	20	20	20
Max.conn.area 400V 3N~ (L1-L3, N, PE) Cu (mm ²)	35	35	35	35	35
Steam (internal thread)	R ¾"	R ¾"	R ¾"	R 1"	R 1"
Condense water (internal thread)	R ¾"	R ¾"	R ¾"	R ¾"	R ¾"
Steam consumption* (kg/h)	45	50	50	60	65

* Other pressure on request

Technical data WD-ICS+

Connection, water, drain and ventilation	WD-153	WD-213	WD-243	WD-333	WD-423
Water quality, hardness (°dH)	2-7	2-7	2-7	2-7	2-7
Hot water conn. 55-70°C (internal thread)	R ½"	R ½"	R ½"	R ½"	R ½"
Cold water connection 5-12°C (internal thread)	R ½"	R ½"	R ½"	R ½"	R ½"
Drain connection, PP pipe (ø mm)	50	50	50	50	50
Water capacity cold water, pressure (kPa)	250-600	250-600	250-600	250-600	250-600
Water capacity cold water, flow (litres/min)	11	11	11	11	11
Water capacity hot water, min/max pressure (kPa)	100/600	100/600	100/600	100/600	100/600
Floor drain, capacity (litres/sec).	3	3	3	3	3
Heat load to the room (total, sensible, latent) (kW)	6,0/3,5/2,5	6,5/3,9/2,6	6,5/3,9/2,6	8,0/4,8/3,2	10,5/6,3/4,2

Size and weight for transportation standard machine*	WD-153	WD-213	WD-243	WD-333	WD-423
Size** (LxWxH (m))	2.1x0.8x2.0	2.7x0.8x2.0	3.0x0.8x2.0	3.9x0.8x2.0	4.8x0.8x2.0
Weight** (kg)	400	510	550	680	790

* Normal delivery in 1 piece, if necessary the machine can be further dismantled

** Packaging included

Dimensional drawings

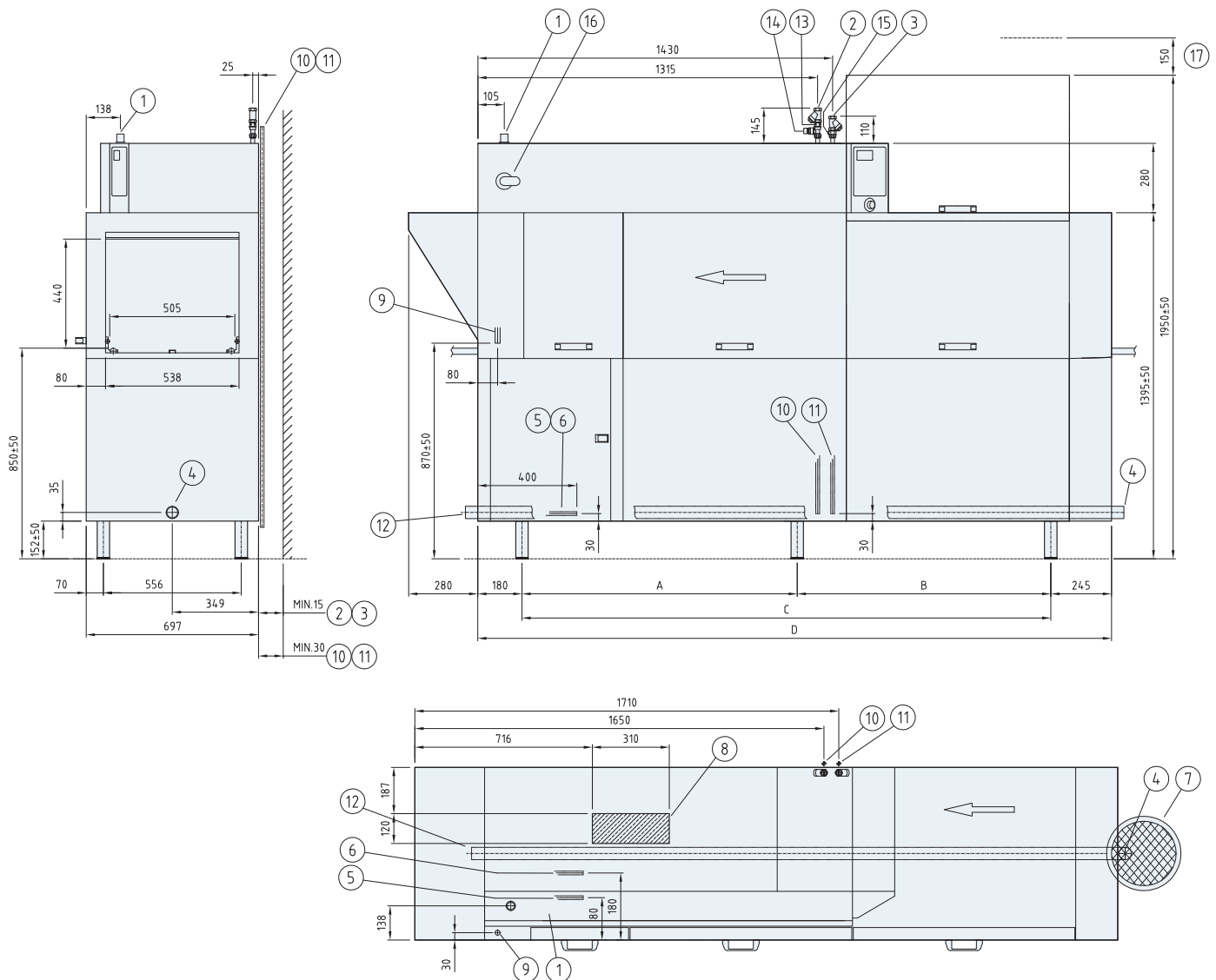

Dimensions

	WD-153	WD-213	WD-243	WD-333	WD423
A	--	--	--	1360	2260
B	--	--	--	1670	1670
C	1230	1830	2130	3030	3930
D*	1655	2255	2555	3455	4355

* Installation length at bench height

Rack conveyor dishwasher ICS+

1. Electrical connection
2. Cold water connection/filter
3. Hot water connection/filter
4. Drain connection
5. Steam connection
6. Condensation water connection
7. Floor drain
8. Exhaust steam condensing battery
9. Alternative electrical connection
10. Alternative cold water connection
11. Alternative hot water connection
12. Alternative drain connection
13. Non-return valve
14. Vacuum valve
15. Detergent dosage outlet
16. Main switch
17. Service space

Technical data PRM-60/90

Technical data	PRM-60	PRM-90
Pump (kW)	0.75	0.75
Tank volume (litres)	30	30
Weight, machine in operation (kg)	150	170
Degree of protection (IP)	55	55

Capacity and operation data	PRM-60	PRM-90
Max. surface temp. at room temp. 20°C (°C)	35	35
Sound level* (dB(A))	68	68

* Measured 1 metre from the machine

Connection, electrically heated	PRM-60	PRM-90
Total connected power (kW)	0.8	0.8
Main fuse 400V 3N~ (A) *	10	10
Max.conn.area 400V 3N~ (L1-L3,N,PE) Cu (mm ²) **	6	6
Electrical connection of the PRM by the dishwasher	Option	Option

* Other voltages on request

** Delivered with 3 meter cable

Connection, water, drain and ventilation	PRM-60	PRM-90
Drain connection, PP pipe (ø mm)	50	50
Water connection from dish machine (ø mm)	50	50
Floor drain, capacity (litres/sec)	3	3
Heat load to the room (total, sensible, latent) (kW)	2,3 / 1,7 / 0,6	2,3 / 1,7 / 0,6

Size and weight	PRM-60	PRM-90
Size * (LxWxH (m))	0.6x0.7x1.4	0.95x0.95x1.4
Weight ** (kg)	155	175

* Normal delivery in 1 piece, If necessary the machine can be further dismantled

** Packaging included

Dimensional drawings

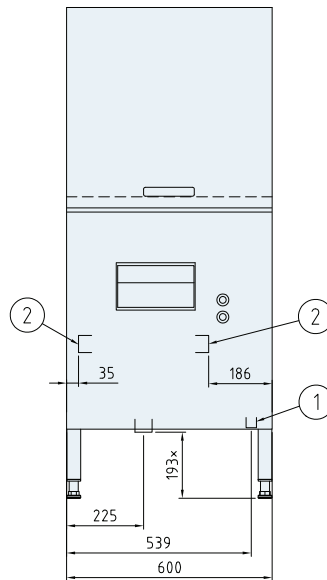
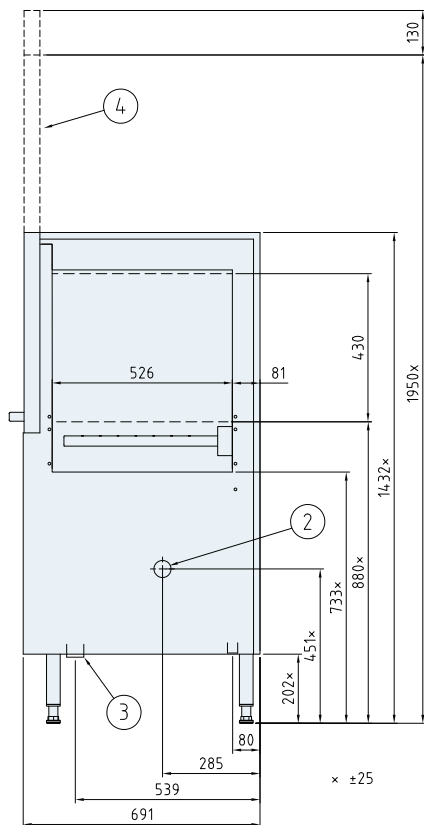

PRM-60

1. Electrical connection *
2. Water connection from dishwasher
3. Drain
4. Door (open position)

* Can be electrically connected by the dishwasher

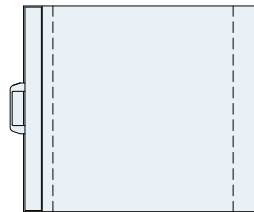

PRM-90

1. Electrical connection *
2. Water connection from dishwasher
3. Drain
4. Door (open position)

* Can be electrically connected by the dishwasher

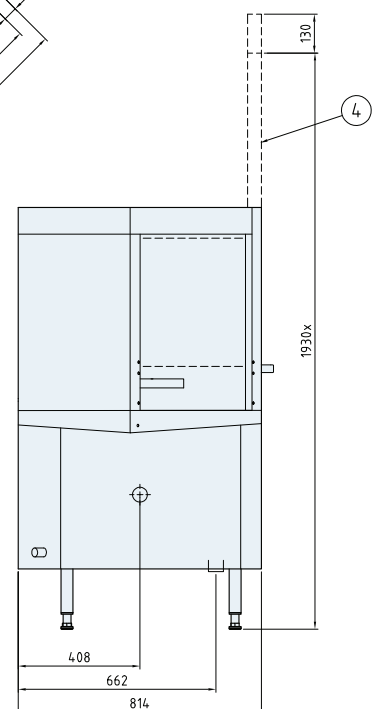
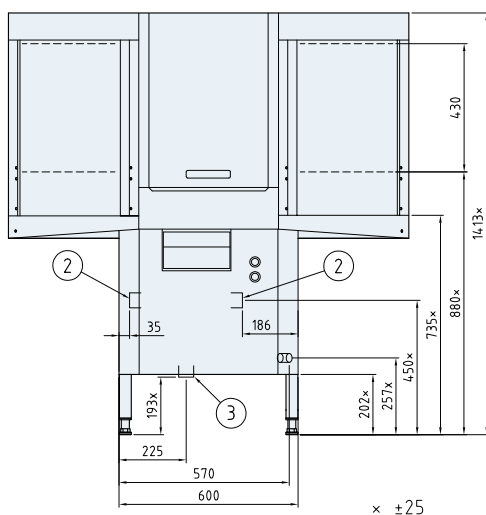
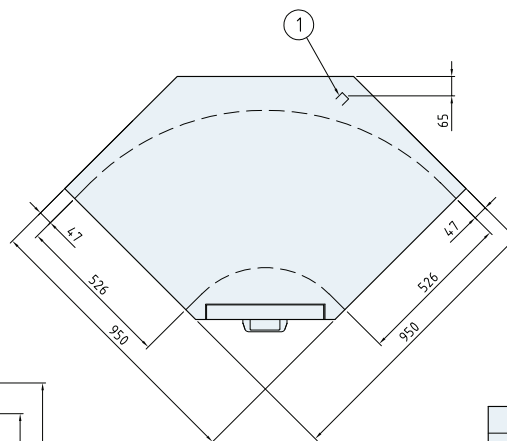

BECAUSE WE DO CARE

Telefon: +46 470 77 12 00
Telefax: +46 470 237 52
Adress: Mårdvägen 4
SE-352 45 Växjö
SVERIGE
E-post: wexiodisk@wexiodisk.com

Wexiödisk 

www.wexiodisk.com

 **WD-B**

FLIGHT TYPE DISHWASHER



Wexiödisk 

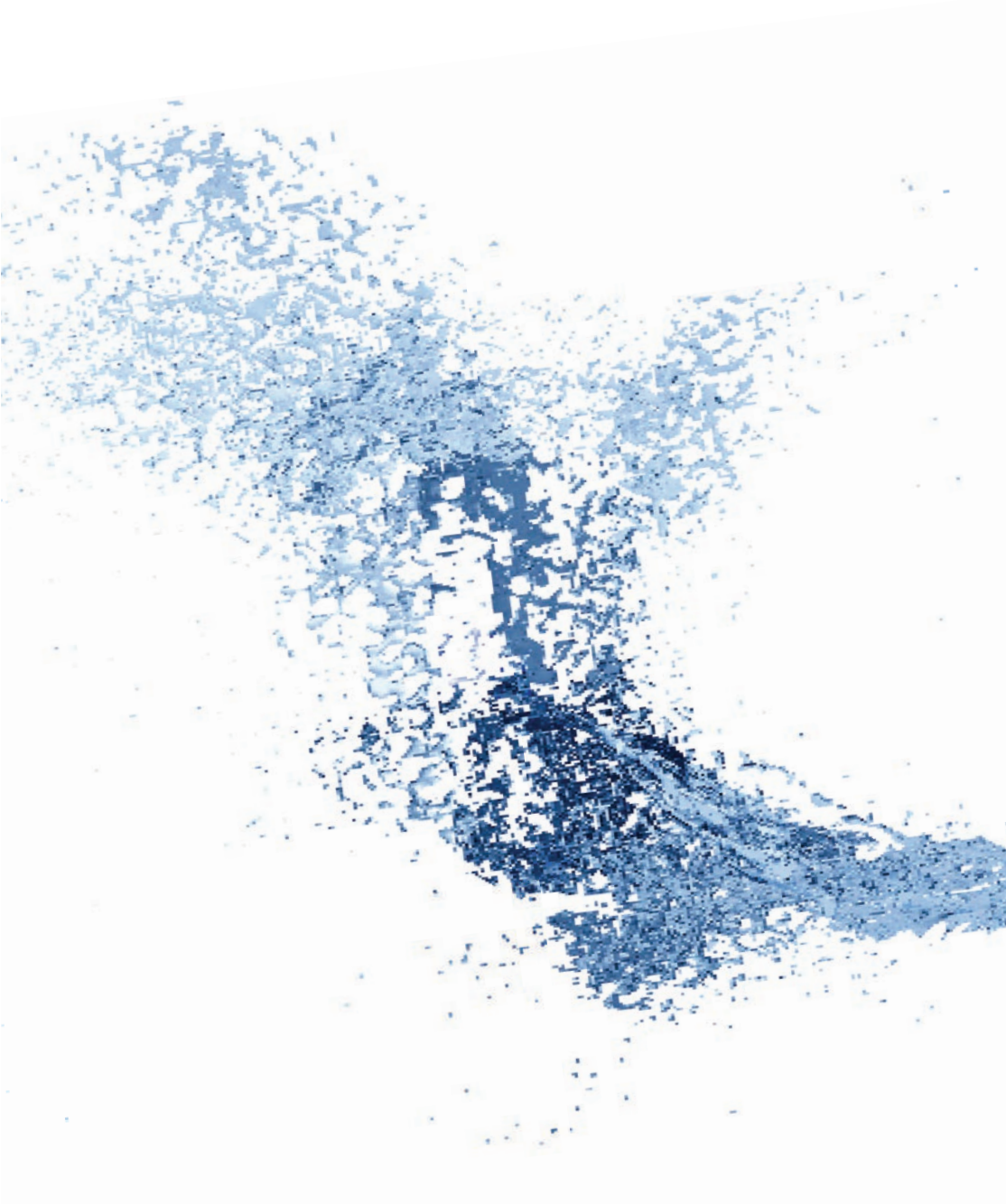

All installations must result in a good reference!

www.wexiodisk.com



The new generation of
flight type dishwashers
for institutional catering such
as flight and hospital kitchens.





When an aircraft lands, it is not only the passengers and luggage that must be taken care of. It is equally important that the crockery, trays and canteens are quickly unloaded, sorted and washed. The world's toughest dishwashing environment. An environment in which we really can and have to show what we are worth.

In many countries and parts of the world and always with the same goal

At Wexiödisk we strive to remain on the leading edge of technical innovations that affect people and the environment. The goal is to create the world's best dishwasher, and we feel that we are well on our way. Our WD-B Green flight type dishwasher has been developed with new technology for minimum operating costs and maximum reliability. The new technology reduces energy consumption by a whole 20 % and requires very little water. WD-B Green is also equipped with double heat recovery, which means that it reuses the heat in both the exhaust ventilation and the final rinse water.

We place a lot of emphasis on providing an ergonomically correct working environment for the user. Examples of this are easy to handle doors which provide good access, wash arms that are easily cleaned and strainers at the infeed and outfeed that can be removed for easy emptying. In addition, the efficient sound and heat insulation contributes to a good working environment in the dishwashing room.



ENERGY CONSUMPTION reduced by as much as 20 %.

DOUBLE HEAT RECOVERY – reuses the heat in both the exhaust ventilation and the final rinse water.

Extremely low WATER CONSUMPTION, from as little as 2.7 litres per minute.

A fully insulated construction reduces the heat emitted from the machine, making the dishwashing room a good WORKING ENVIRONMENT and contributing to lower operating costs.

The machine is easily connected to the network and computer using WEB Tool. Information on costs, and water and energy consumption are read off so that applicable hygiene requirements according to HACCP are met.

LONG SERVICE LIFE AND VERY SERVICE-FRIENDLY – made entirely from stainless steel, easy access for servicing

Low DETERGENT CONSUMPTION due to the controlled water turnover in the washing tanks.

Customised for optimal ergonomics and economy

The machine is made up of several washing zones. The choice of the number of washing zones is determined by the number of items for washing and the time available. To achieve the best wash results the WD-B Green is designed with extra long washing zones of a full metre, and has the longest final rinse zone on the market at 1125 mm. This reduces water movement between the zones, otherwise known as carry over. Carry over involves the risk of dirty water from previous washing zones being carried into the next tank where there is cleaner water. It is particularly important to avoid this between the chemical wash and the final rinse tank.

Wexiödisk customises solutions for each individual application and ensures that the machines run with a natural work flow.

Clean Rinse for perfect results

The Clean Rinse function is another one of the many advantages of the WD-B Green. The final rinse water is recycled for extra rinsing of the items and the washing conveyor. The Clean Rinse function provides a perfect rinsing result, with lower water consumption.

Efficient handling

The wide sides of the flight type machine act as draining surfaces and facilitate the loading and unloading work. It is a simple matter to stack items such as plates and trays before they are taken elsewhere. One or two people can work on either side of the loading and unloading for optimal flexibility. By placing the drying zone air inlets under the unloading, the working environment at the unloading end is improved since only a minimal amount of warm air escapes from the machine. As a result, the staff experience an improved working environment.

Fitted strainers

Both the infeed and outfeed have fitted, generously dimensioned strainers for ease of use. The strainers are located on the front or the back of the machine according to the layout of the dishwashing room.





A strong concept with a host of options

HIGH PRESSURE WASHING PUMPS

For example, extra high pump capacity can sometimes be required for washing heavily soiled items. We can supply 3 kW pumps for these occasions.

STEAM HEATING

There are two different versions of WD-B Green available with steam heating.

- Normal pressure steam 150 - 250 kPa. Washing tanks, final rinsing and drying zones are steam heated
- Low pressure steam 50 - 140 kPa. Washing tanks and final rinsing are steam heated. Drying zones are mains powered.

CONNECTION VOLTAGE

Standard connection for WD-B Green is 400 Volt, 3-phase 50 Hz with zero; other alternatives are 200 or 230 Volt, 3-phase 50 or 60 Hz without zero.

LOADING

The loading sometimes needs to be suited to local conditions, and is available in the following lengths: 900, 1125, 1500, 2025, 2625 and 3000 mm.

EXTENDED CHEMICAL WASH ZONE

An extended zone is beneficial, for example, when washing long items such as canteens, in order to reduce splashing between the tanks. The extension also provides a longer contact time for the chemical wash, which helps increase the machine's capacity. The first chemical wash zone can be extended by 250 or 500 mm towards the pre-wash zone.

INTERMEDIATE RINSE

The intermediate rinse is placed after the pre-wash zone. Return water from the final rinse is recycled for an extra rinse to keep the chemical wash tank cleaner for a longer period, achieve the best wash results and allow for long intervals between water changes. With intermediate rinse the pre-wash zone is plus 250 mm, in total 1250 mm.

UNLOADING

The unloading is adapted to the local conditions, and is available in the following lengths: 900, 1125, 1500, 2025, 2625 and 3000 mm.

DEMINEALISED WATER IN THE FINAL RINSE

For markets that need to treat incoming water, e.g., with RO equipment, stainless steel pipes and couplings for the final rinse are available as optional extras.

LOCATION OF CLEANING FILTERS

Strainers are located at the loading and unloading on the front of the machine as standard. The cleaning filters can be placed on the back of the machine, if, due to local conditions (other machines, pillars, etc.) this is more practical.

EXTRA WIDE MACHINE

With an accessory the machine conveyor can be widened, for extra high capacity. (750 mm belt)

Collision guard It is common for dishwashers to be damaged by trolleys etc being used in the dishwashing room. To prevent this, an optional collision guard in 50 mm stainless steel tube can be fitted to the entire front and corners.



The work surfaces are flush with the conveyor, which makes it very easy to move fully loaded washing baskets sideways. It is, then, not necessary to lean over the conveyor to lift the baskets. (standard)



Adjustable washing time

Different washing times are needed depending on how heavily soiled the items are. The washing time is set to one of six different levels using a knob on the panel, which makes it easier for the user and gives higher flexibility in the kitchen. The selected time appears on the display. Simple and easy to understand! (standard)



Adjustable rinse pressure The rinse pressure in the lower washing arms can be adjusted using a lever. Doing this increases the mechanical effect and is beneficial if wash ware is more heavily soiled. (option)



Get ahead with innovative functionality

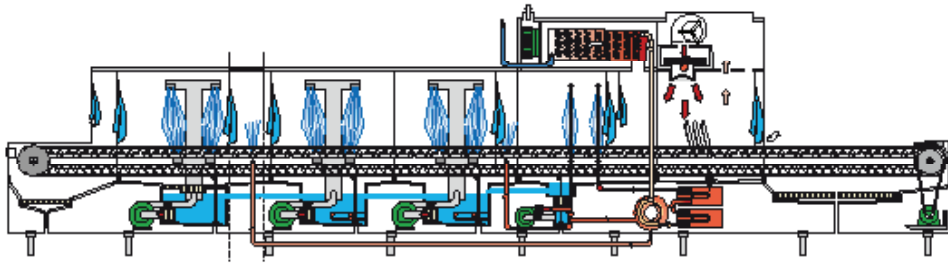

Sensor controlled automation

With automatic operation, the photocell registers infeed and starts the machine. The final rinse starts once the load reaches the final rinse zone. If no extra items are loaded, the machine stops automatically. The machine restarts once the photocell is reactivated.

Intermediate rinse (option)

An intermediate rinse can be included after the pre-wash zone. Here the items are rinsed as they leave the pre-wash zone. Rinsing prevents food residue and pre-wash water from entering the chemical wash zone. This improves results, lowers detergent consumption and allows for longer washing periods without the water needing to be changed. The intermediate rinse reuses water from the final rinse tank, once it has passed through the heat exchanger.

Clean Rinse

The new Clean Rinse function enhances the effectiveness of the final rinse. The items and the washing conveyor pass an additional rinse ramp before reaching the final rinse zone, which keeps the water in the final rinse tank cleaner. This results in a further reduction in fresh water consumption.

Double heat recovery

The warm, damp air inside the machine is drawn through the condenser, where it is cooled by the incoming cold water. The cold water is led through the condensing battery, where it is pre-heated to around 50 °C. The water is then fed to the heat exchanger. Here the water temperature is raised to around 53 °C. With normal operation, the machine only consumes cold water.

Double final rinse system

The final rinse uses water at 85 °C and recirculating (reused) water. A filter on the front of the machine prevents the rinsing nozzles from becoming blocked by the circulating rinsing water.

Water is drained from the recirculating system, half of this is cooled in the heat exchanger and then reused for the pre-wash, intermediate rinse or pre-rinse. The rest is initially used in the Clean Rinse function, and is then used to dilute the chemical wash tanks. As a result, the amount of detergent consumed is extremely low.

Drying zone

The drying zone has well sound-insulated fans that blow air onto the washed items from above and below. The fans work partly by recirculating the heated air in the drying zone, which significantly reduces the amount of power required.

Safety

If a door is opened during operation, the machine stops automatically. The machine must be restarted after the door is closed. A limit switch stops the conveyor if there are any items left on it. The machine starts automatically on removal of the item(s). An overload switch stops the conveyor drive motor if an item jams the conveyor, and the conveyor automatically reverses a short distance. The machine can be restarted after the item is freed.



WD-B Green conveyors have strong fingers as well as shafts and conveyor links in stainless steel, which gives them a very long service life. The design of the conveyors keeps the items stable during their passage through the machine. Being able to place the items in the right position and at the correct angle in relation to the direction of the water sprays contributes to excellent wash results.

Large range of conveyors enhances flexibility



1. High capacity conveyor with recessed fingers (HC conveyor)
2. Extra wide conveyor belt of 750 mm, for extra capacity.
3. Standard conveyor with recessed fingers intended for shallow or deep plates, "coffee-break" crockery and trays. Also suitable for baskets.
4. On a standard conveyor, both deep and shallow plates stand at the best angle for an optimal result.
5. Finger conveyor with vertical fingers designed for shallow or deep plates, "coffee-break" crockery, trays, etc.
6. Flat conveyor for canteens, pots and plastic storage trays.
7. Special conveyor for canteens
8. Special conveyor for insulated trays such as Temprite or equivalent makes.

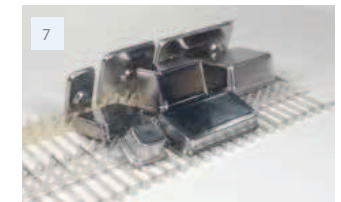
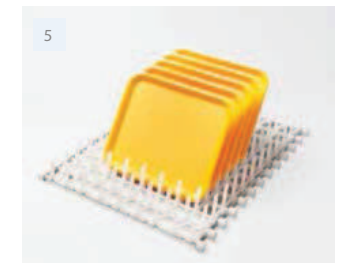
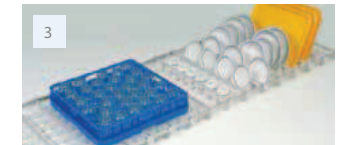

+ Dishwasher models

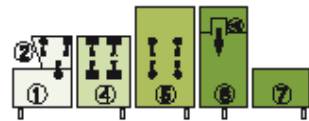

WD-B 500*

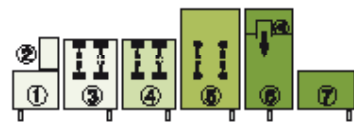

WD-B 600

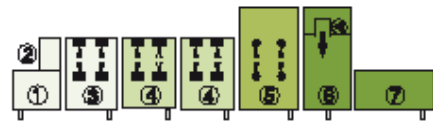

WD-B 700

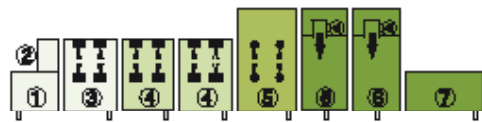

WD-B 800

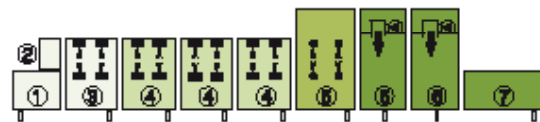

WD-B 900

Zone	Zone length in mm
WD-B 500	
1 Infeed incl. pre-rinse zone	1125
2 Steam hood	-
4 Chemical wash	1000
5 Double final rinse	1125
6 Drying zone	875
7 Outfeed	1125
Total length	5250
WD-B 600	
1 Infeed incl. steam hood (L=300 mm)	900
2 Steam hood	-
3 Pre-wash	1000
4 Chemical wash	1000
5 Double final rinse	1125
6 Drying zone	875
7 Outfeed	1125
Total length	6025
WD-B 700	
1 Infeed incl. steam hood (L=300 mm)	900
2 Steam hood	-
3 Pre-wash	1000
4 Chemical wash	2000
5 Double final rinse	1125
6 Drying zone	875
7 Outfeed	1500
Total length	7400
WD-B 800	
1 Infeed incl. steam hood (L=300 mm)	900
2 Steam hood	-
3 Pre-wash	1000
4 Chemical wash	2000
5 Double final rinse	1125
6 Drying zone	1500
7 Outfeed	1500
Total length	8025
WD-B 900	
1 Infeed incl. steam hood (L=300 mm)	900
2 Steam hood	-
3 Pre-wash	1000
4 Chemical wash	3000
5 Double final rinse	1125
6 Drying zone	1500
7 Outfeed	1500
Total length	9025

* Pre-rinse zone without fresh water supply

WD-B 500 has a pre-rinse zone which recirculates water from a tank. The wash ware is rinsed from both above and below. The material rinsed off is effectively collected in a double filter system, which can be emptied from the front of the machine while it is running. The increased rinsing does not affect operating costs but reduces the need for removing residue from plates beforehand. And the water in the following washing zone is kept cleaner, which reduces consumption of chemicals, water and energy.

Technical specifications

Technical data	WD-B 500	WD-B 600	WD-B 700	WD-B 800	WD-B 900
Pump motor, pre-wash (kW)	0.74	2.35	2.35	2.35	2.35
Pump motor, chemical wash 1 (kW)	2.35	2.35	2.35	2.35	2.35
Pump motor, chemical wash 2 (kW)	-	-	2.35	2.35	2.35
Pump motor, chemical wash 3 (kW)	-	-	-	-	2.35
Pump motor, recirculating rinse (kW)	0.74	0.74	0.74	0.74	0.74
Heat recovery fan (kW)	0.19	0.19	0.19	0.19	0.19
Fan, drying zone 1 (kW)	0.65	0.65	0.65	0.65	0.65
Fan, drying zone 2 (kW)	-	-	-	0.65	0.65
Drive motor, belt (kW)	0.15	0.15	0.15	0.15	0.15
Booster heater 1 final rinse (kW)	9	9	9	9	9
Booster heater 2 final rinse (kW)	6	6	6	6	6
Tank heater, chemical wash 1 (kW)	18	18	12	12	12
Tank heater, chemical wash 2 (kW)	-	-	12	12	12
Tank heater, chemical wash 3 (kW)	-	-	-	-	9
Heater, drying zone 1 (kW)	6	6	6	6	6
Heater, drying zone 2 (kW)	-	-	-	-	6
Heat recovery, cooling surface (m ²)	52	52	52	52	52
Tank volume, pre-wash tank (litres)	20	104	104	104	104
Tank volume, chemical wash tank 1 (litres)	120	120	120	120	120
Tank volume, chemical wash tank 2 (litres)	-	-	120	120	120
Tank volume, chemical wash tank 3 (litres)	-	-	-	-	120
Tank volume, final rinse tank (litres)	21	21	21	21	21
Weight, machine in operation (kg)	1250	1480	1770	1930	2280
Enclosure class (IP)	55	55	55	55	55

Capacity and operating data	WD-B 500	WD-B 600	WD-B 700	WD-B 800	WD-B 900
Capacity, HC conveyor, normal wash (plates/hour)	3190	3750	5140	5140	6525
Capacity, HC conveyor, as per DIN 10510 (plates/hour)	2550	3000	4110	4110	5220
Capacity, standard conveyor, normal wash (plates/hour)	2304	2907	4000	4000	5102
Capacity, standard conveyor as per DIN 10510 (plates/hour)	2016	2535	3504	3504	4464
Contact length according to DIN 10510 (mm)	2300	2700	3700	3700	4700
Belt speed according to DIN 10510 (m/min)	1.15	1.35	1.85	1.85	2.35
Cold water consumption, normal final rinse (litres/hour) *	160-210	170-220	190-240	190-240	210-260
Regeneration of the chemical wash (l/h)	75	75	75	75	75
Steam consumption at 150-250 kPa (kg/hour) **	63	63	71	71	92
Steam consumption at 50-140 kPa (kg/hour) **	52	52	59	69	72
Surface temperature at a room temperature of 20°C (°C)	35	35	35	35	35
Noise level (dB(A)) ***	70	70	70	70	70

Connection, electrically heated machine	WD-B 500	WD-B 600	WD-B 700	WD-B 800	WD-B 900
Total connected power (kW)	44	46	54	54	72
Main fuse 400 V 3N~ (A) ****	80	80	100	100	125
Max. connection area 400 V 3N~ (L1 - L3, N, PE) Cu (mm ²)	70	70	70	70	70

* The water consumption depends on local conditions. An exact adjustment is made during installation.

** When the machine is steam-heated

*** Measured 1 metre from the side of the machine

**** Other connection voltages on request

Technical specifications

Connection, steam-heated machine 50-140 kPa*	WD-B 500	WD-B 600	WD-B 700	WD-B 800	WD-B 900
Total connected power (kW)	10.8	12.4	14.8	15.4	23.8
Main fuse 400 V 3N- (A) **	35	35	50	50	63
Max. connection area 400 V 3N~ (L1-L3,N,PE) Cu (mm ²)	35	35	35	35	70
Steam connection (external thread)	R 1"	R 1"	R 1 1/4"	R 1 1/4"	R 1 1/2"
Condensing water connection (internal thread)	R 3/4"	R 3/4"	R 3/4"	R 3/4"	R 3/4"
Connection, steam-heated machine 150-250 kPa	WD-B 500	WD-B 600	WD-B 700	WD-B 800	WD-B 900
Total connected power (kW)	4.8	6.4	8.8	9.4	11.8
Main fuse 400 V 3N- (A) **	20	20	25	35	35
Max. connection area 400 V 3N~ (L1-L3,N,PE) Cu (mm ²)	35	35	35	35	35
Steam (external thread)	R 3/4"	R 3/4"	R 1"	R 1"	R 1 1/4"
Condensing water (internal thread)	R 3/4"	R 3/4"	R 3/4"	R 3/4"	R 3/4"
Water, drain and ventilation connections	WD-B 500	WD-B 600	WD-B 700	WD-B 800	WD-B 900
Water quality, hardness (°dH)	2-7	2-7	2-7	2-7	2-7
Hot water connection 50-70°C (external thread)	R 3/4"	R 3/4"	R 3/4"	R 3/4"	R 3/4"
Cold water connection, 5-12°C (external thread)	R 3/4"	R 3/4"	R 3/4"	R 3/4"	R 3/4"
Drain connection, PP pipe (ø mm)	50	50	50	50	50
Water capacity, pressure (kPa)	300-600	300-600	300-600	300-600	300-600
Water capacity, flow (litres/min.)	18	18	18	18	18
Floor drain, capacity (litres/sec)	3	3	3	3	3
Heat load to the room (total, sensible, latent (kW))	10/6/4	10/6/4	11.5/7/4.5	11.5/7/4.5	15/9/6
Size and weight for transportation.	WD-B 500	WD-B 600	WD-B 700	WD-B 800	WD-B 900
Standard, divided machine***					
Size part 1**** (LxWxH (m))	3.4x1.1x2.0	3.2x1.1x1.5	4.2x1.1x1.5	4.2x1.1x1.5	5.2x1.1x1.5
Size part 2**** (LxWxH (m))	2.35x1.1x1.55	3.3x1.1x2.1	3.7x1.1x2.1	4.3x1.1x2.1	4.3x1.1x2.1
Weight part 1**** (kg)	780	550	750	770	1000
Weight part 2**** (kg)	440	700	700	820	820

- * Electrically heated drying zone
- ** Other connection voltages on request
- *** Normal delivery in two parts. Option of delivery in more parts.
- **** Including packaging

Dimensions table

Type	WD-B 500	WD-B 600	WD-B 700	WD-B 800	WD-B 900
A (length)	5250	6025	7400	8025	9025
B (width)	1038	1038	1038	1038	1038
C (height)	2020	2020	2020	2020	2020
D	3044	3044	3419	4044	4044
E	---	---	1810	1810	1810
F	2450	2450	2825	3450	3450
G	2520	2520	2895	3520	3520
H	2605	2605	2980	3605	3605
I	2012	2212	2587	3212	3212
J	1625	1400	1400	1400	1400
K	---	---	4190	4815	5185

Dimension sketches WD-B Green

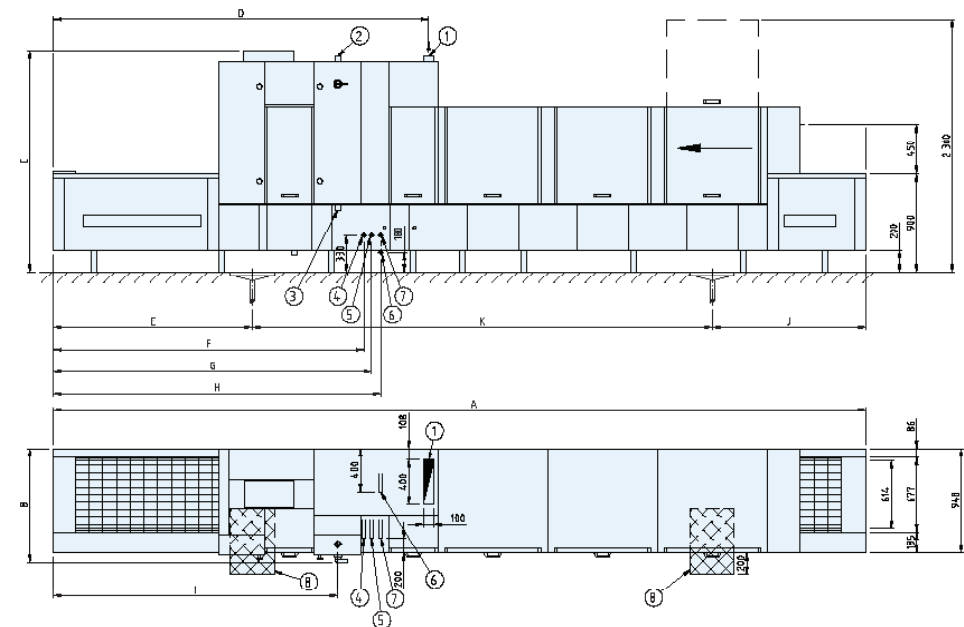

Drawing no. 27888

1. Extractor 400x100 mm without damper. Air quantity, see technical specs.
2. Electrical connection from ceiling
3. Alternative electrical connection from floor
4. Hot water connection *
5. Cold water connection *
6. Condensation water connection (steam-heated machine)
7. Steam connection * (steam-heated machine)
Steam pressure 150-250 kPa (Fully steam-heated machine).
8. Floor drain 400x600 mm.

* Connection from floor or ceiling



Wexiödisk 

TELEPHONE: +46 470 77 12 00 FAX: +46 470 237 52
ADDRESS: Mårdvägen 4 SE-352 45 Växjö SWEDEN
E-MAIL: wexiodisk@wexiodisk.com WEBB: www.wexiodisk.com

Cutlery sorter

■ ACS 800 Dynamic



Wexiödisk^W
BECAUSE WE DO CARE



All installations must result in a good reference!

www.wexiodisk.com



■ ACS 800 Dynamic

The new generation of cutlery sorter for institutional catering such as hospital, staff restaurants and universities.



ACS 800 Dynamic tried-and-tested automatic cutlery sorter

ACS automatic cutlery sorters have been used in institutional kitchens for over 20 years in the Nordic countries, Europe, Asia and Australia. Hospitals, universities, staff restaurants and the flight catering industry are examples of customers we have helped over the years.

ACS 800 Dynamic completely eliminates time-consuming manual cutlery sorting, leading to cost savings and a more efficient work flow in the dishwashing room. The fully automatic cutlery sorting machine can be connected to a cutlery dishwasher or as a standalone machine.



With the Wexiödisk ACS 800 Dynamic cutlery sorter, the manual cutlery sorting that used to take up so much time is eliminated. The cutlery is now manually fed into the machine, or automatically picked up from a tray or via a soaking conveyor. This method saves many man-hours in the dishwashing room.

When the cutlery sorter is connected to a dishwasher with a cutlery track, the cutlery doesn't need to be washed twice. Thanks to the Dynamic function, the sorting unit lets you know when it's time to change the boxes full of sorted cutlery. The handling time is reduced to an incredibly low five minutes per hour. So the operator can look after the cutlery sorter alongside their other tasks.

By using the buffer conveyor to temporarily store washed cutlery, the sorting can be delayed- in order to offset peak loads in the dishwashing room. In this way the work can be distributed more evenly throughout the day.

Smart cutlery handling saves man-hours in the dishwashing room



USER-FRIENDLY – simple to operate and read off operating status

COST-SAVING – no more manual cutlery sorting

EFFICIENT – the cutlery only needs to be washed once

HYGIENIC – no fingers come into contact with the cutlery

EASY SERVICING – easy and hassle-free to replace spare parts

Hygienic

No hands or fingers come into contact with the washed cutlery. The guest is the first person to touch the cutlery after it has passed through the dishwasher, been washed and then rinsed in fresh water at 90°C.

User-friendly

On the control panel there are only two buttons to operate plus a display showing instructions in the local language. The display provides simple instructions.

A light bar in a high position makes it easy even at a distance to see the operating status of the cutlery sorter. A yellow light flashes when sorted cutlery boxes are full. That means it's time to change all the boxes full of sorted cutlery.

The machine is fitted with reinforced soundproofing. The infeed, outfeed and the end box have sound traps to reduce the noise from the cutlery.

Easy servicing

In conjunction with the installation, we always train users and local technicians in how to look after the machine and perform preventative maintenance. We also discuss a service contract with each customer.

The machine comes complete with a spare parts kit containing the most common wearing parts to ensure that no interruptions occur.





Optimise the work flow and create efficiency

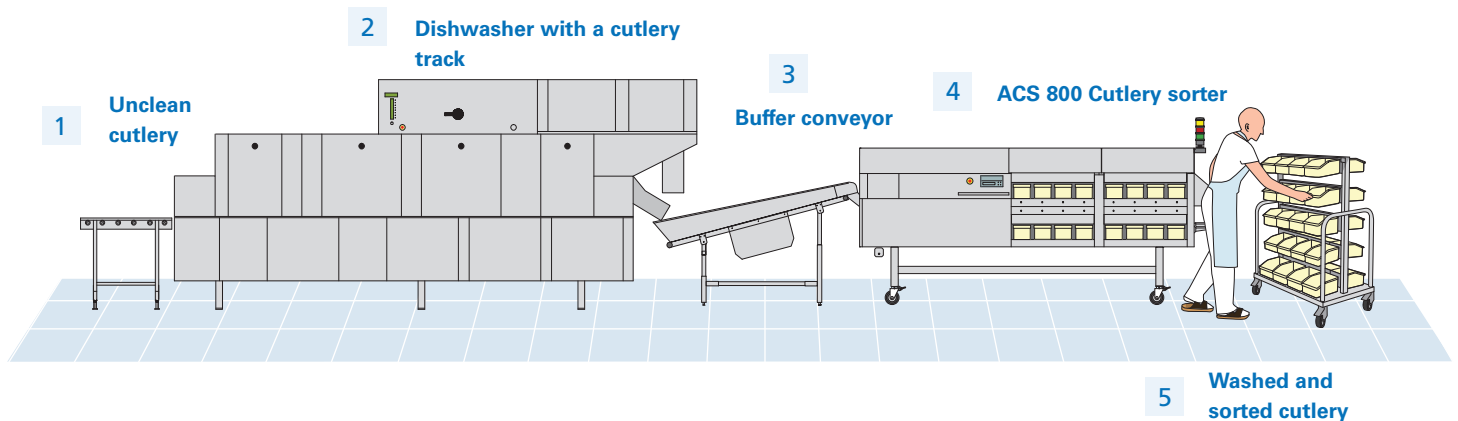

1 Unclean cutlery can be fed into the machine in different ways:

- By being automatically picked up from a tray.
- Via a soaking conveyor before the dishwasher, used for cutlery with dried-on food.
- By being manually fed into the dishwasher.

2 Cutlery dishwasher

To achieve a fully automatic and efficient work flow in the kitchen, several different types of dishwasher can be used together with the cutlery sorter.

- Cutlery dishwasher, e.g. ACS 47D
- Combined tray and cutlery dishwasher, e.g. WD-66CT
- Conveyor dishwasher with cutlery track, e.g. WD-B 500-900

3 Buffer conveyor

The buffer conveyor is used to transport clean cutlery from the dishwasher to the cutlery sorter and also to temporarily store cutlery. When cutlery is stored temporarily, production stoppages are offset and the workload in the dishwashing room becomes more regular. The length of the conveyor determines the storage capacity. The longer the conveyor, the more cutlery can be stored. The standard lengths are 1.5 to 3.5 metres, but lengths can also be adapted to suit the customer's needs.

4 ACS 800 Cutlery sorter

Capacity of 2,500 to 3,600 items of cutlery per hour depending on the size, weight and shape of the cutlery. Usually three or four cutlery items (spoon, fork, knife), but up to eight different items can be sorted simultaneously. The sorter can be pre-programmed to sort virtually all cutlery as long as the length of the item does not exceed 215 mm.

5 Rack trolley

The rack trolley is used to both store and transport clean and sorted cutlery.

Accessories for optimal customisation



ACS BUFFER CONVEYOR

The ACS buffer conveyor is an integral part of the cutlery sorter. The buffer conveyor is available in several standard lengths between 1.5 and 3.5 metres to enable it to be adapted to the required layout.

The buffer conveyor is not only used to transport washed cutlery to the sorter but also to temporarily store cutlery, making it possible to put back the sorting for a while. When, for instance, there is a lunch session with lots of guests in a short period of time, the cutlery can be stored on the buffer conveyor and sorting completed later. The length of the buffer conveyor must then be adapted to the amount of cutlery that needs to be stored. The rule of thumb is 600 to 800 cutlery items per metre of buffer conveyor. We can also make customised buffer conveyors.

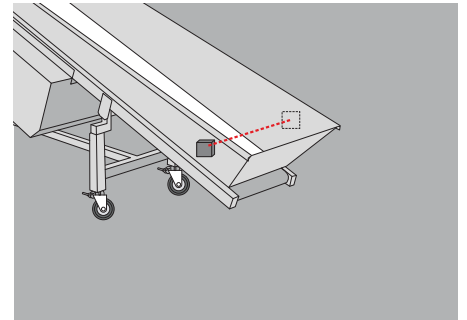

ACS LEVEL DETECTOR Used when the cutlery sorter is connected to the dishwasher. The level detector is positioned on the bottom part of the buffer conveyor. The level detector controls the forward feed and temporary storage on the buffer conveyor at times when the cutlery sorter cannot accept any more cutlery.



ACS CLEANER For effective cleaning of the cutlery sorter's conveyors, which must be cleaned every four hours of operation.



ACS CUTLERY BOX Handling is efficient and hygienic by using ACS cutlery boxes to store and transport sorted items of cutlery. No-one's hands touch the clean cutlery before the guest's do.



ACS RACK TROLLEY Used complete with 40 cutlery boxes and accommodates around 2,000 cutlery items. For storing and transporting sorted cutlery.

■ Technical specifications

Technical data	ACS 800
Number of cutlery items	Up to 8 different items
Capacity	2,500–3,600 cutlery items/hour
Cutlery size	Max. length 215 mm, width 5–46 mm, height 1–30 mm
Noise level	78 dB(A) (measured 1 metre from the side of the machine)
Degree of protection (IP)	54–65
Electrical connection	230 V 1N 50/60 Hz 0.3 kW
Size and weight for transport: Cutlery sorter	3.1 x 1 x 1.3 m; 500 kg
Size and weight for transport: Buffer conveyor	1.2 x 0.6 m x L (1.5–6 m); 45-80 kg

■ Part numbers

	Part number
ACS 800 model cutlery sorter	WD235.800
Accessory	
Buffer conveyor 1.5 m	WDACS123030
Buffer conveyor 2.0 m	WDACS123094
Buffer conveyor 2.5 m	WDACS123095
Buffer conveyor 3.5 m	WDACS123096
Cutlery box	WD4550150
Level detector	WDACS120537
Rack trolley	WDACS123016
Cleaner 12 x 0.5 l	WDACS120000
Spare parts kit	WDACS123550
Buffer conveyor, straight connection	WD235.0830
Buffer conveyor, connection 90°	WD235.0831
Buffer conveyor, connection 180°	WD235.0832
Buffer conveyor, adjustable 30–80°	WD235.0833

■ Dimension drawings for ACS 800

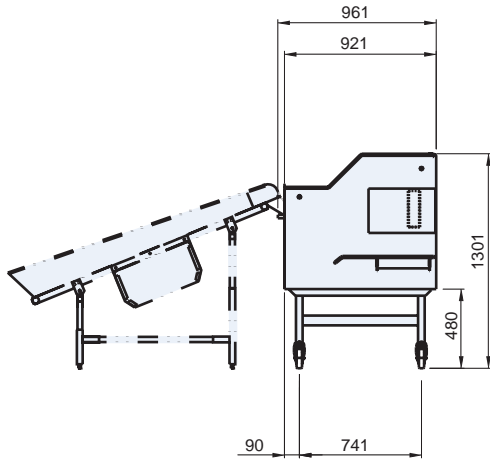

Buffer conveyor, front connection

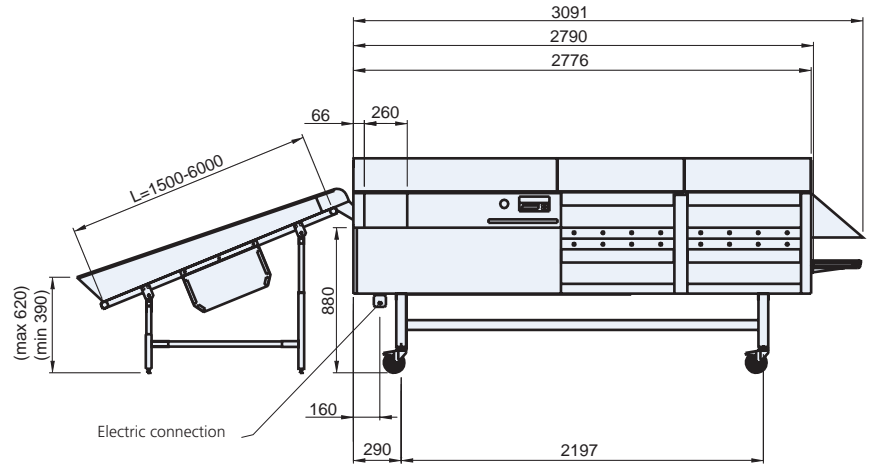

Buffer conveyor, side connection

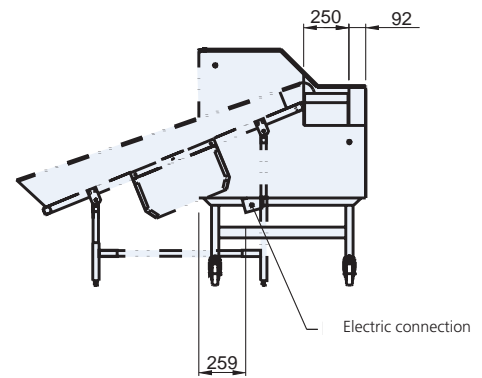
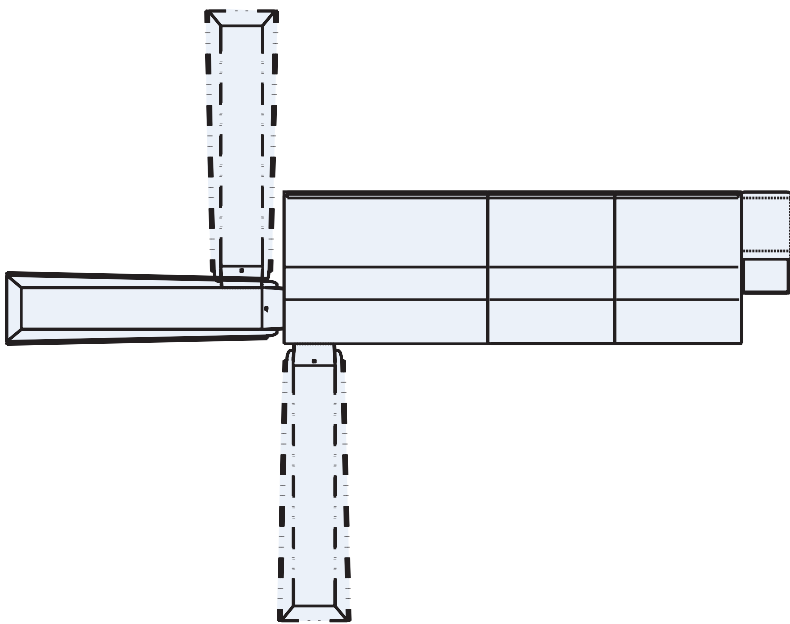

Buffer conveyor, rear connection 90°

gruporoig.es

Grupo Roig

Polígono Industrial A Tomada, nº 61
15940 A Pobra do Caramiñal
(A Coruña)

☎ 981 832 321

✉ gruporoig@gruporoig.es

[@gruporoig](#)

roig
grupo