



pujadas[®]
A VOLLRATH[®] COMPANY

rosg
grupo

VOLLRATH®

grill



pujadas®
grill



All the production of ovens and open grills, from design to manufacturing, is carried out in our new facilities. We control the entire production process so that our products exceed our customers' expectations: high quality and robustness with the Pujadas guarantee.

Toda la producción de hornos y brasas abiertas, desde el diseño hasta la fabricación, se lleva a cabo en nuestras nuevas instalaciones. Controlamos todo el proceso productivo para que nuestros productos respondan con creces a las expectativas de nuestros clientes: alta calidad y robustez con la garantía de Pujadas.

La production, la conception et la fabrication des fours et des grilles ouverts, sont entièrement réalisées dans nos nouvelles installations. Nous contrôlons l'ensemble du processus de production afin que nos produits répondent largement aux attentes de nos clients : haute qualité et robustesse avec la garantie de Pujadas.

Made by us, made here

Hechos por nosotros, hechos aquí
Fabriqués par nous, fabriqués ici

We make

And as specialists in professional kitchenware, we offer our customers a comprehensive grilling solution with a wide range of accessories and kitchenware for cooking and presentation.

Además, como especialistas en menaje profesional, ofrecemos a nuestros clientes una solución global para la cocina a la brasa con una amplia gama de accesorios, complementos y menaje de brasa para cocción y presentación.

De plus, en tant que spécialistes des ustensiles de cuisine professionnels, nous proposons à nos clients une solution globale pour la cuisine au grill avec une large gamme d'accessoires, de compléments et d'ustensiles de cuisine au grill pour la cuisson et la présentation.





We know how

**The soul of a manufacturer
with a century of wisdom**

Alma de fabricantes con manos centenarias
L'âme des fabricants aux mains centenaires



After more than 100 years of manufacturing for the professional catering industry, we have put all the knowledge we have acquired at the service of grill cooking. Turning traditional stainless steel into something completely new was a challenge we couldn't pass up.

Tras más de 100 años fabricando para la restauración profesional, hemos puesto todo el conocimiento adquirido al servicio de la cocina de brasa. Convertir el acero inoxidable de siempre en algo totalmente nuevo era un reto que no podíamos dejar escapar.

Après plus de 100 ans de fabrication pour la restauration professionnelle, nous avons mis toutes les connaissances acquises au service de la cuisine au charbon de bois. Transformer l'acier inoxydable de toujours en quelque chose de totalement nouveau était un défi que nous ne pouvions pas manquer.



we grill



New grill cooking is born from the chef's passion for finding that unique and unmistakable flavour that only the grill can offer. And with that same passion we created Pujadas Grill, offering everything a chef needs to transform an idea into the best culinary experience.

La nueva cocina a la brasa nace de la pasión del chef por encontrar ese sabor único e inconfundible que sólo la brasa puede ofrecer. Y con esa misma pasión creamos Pujadas Grill, ofreciendo todo lo que un chef necesita para transformar una idea en la mejor experiencia culinaria.

La nouvelle cuisine au grill est née de la passion du chef pour trouver cette saveur unique et incomparable que seule la cuisson au grill peut offrir. Et avec cette même passion, nous avons créé Pujadas Grill, offrant tout ce dont un chef a besoin pour transformer une idée en la meilleure expérience culinaire.



Where steel and fire work their magic

*Donde el acero y el fuego hacen su magia
Là où l'acier et le feu opèrent leur magie*

Discover the secrets of grilling in a versatile and welcoming space specially designed for chefs and foodservice professionals to learn first-hand about the versatility and performance of this type of cooking.

Descubre los secretos de la brasa en un espacio versátil y acogedor especialmente diseñado para que chefs y profesionales del Foodservice conozcan de primera mano la versatilidad y rendimiento de la cocina a la brasa.

Découvrez les secrets de la cuisson au grill dans un espace polyvalent et accueillant spécialement conçu pour les chefs et les professionnels du Foodservice afin d'apprendre de la source même la polyvalence et la performance de la cuisson au grill.



The Lab

A centre for training and culinary creativity where we provide comprehensive support on our charcoal ovens and open grills: in-person and online demonstrations, support, setup and training.

Un centro de formación y creatividad culinaria en el que realizar un acompañamiento integral en la venta de nuestros hornos y brasas abiertas: demostraciones presenciales y online, soporte y puesta en marcha, formaciones.

Un centre de formation et de créativité culinaire où apporter un accompagnement complet dans la vente de nos fours et grills ouverts : démonstrations en présentiel et en ligne, accompagnement et mise en marche, formations.





Pujadas
grill

Pujadas
grill



Index

Charcoal Ovens **12**

Hornos de brasa / Fours à braise

Open Grills **22**

Brasas abiertas / Grills ouverts

Grillbox **36**

Grillbox / Grillbox

Smoker **40**

Ahumador / Fumoir

Charcoal **44**

Carbón / Charbon

Accessories **48**

Accesorios / Accessoires

Cookware **54**

Menaje / Batterie

Technical information **65**

Información técnica / Informations techniques

pujadas
grill

OVEN 90

CLOSED

OPEN

PUSH



A chef is seen from behind, wearing a black long-sleeved shirt with the text 'we grill' printed on the back. The chef is standing in a kitchen with a white tiled wall. To the left, a charcoal oven is open, showing bright orange flames. The chef's hands are near the oven. The overall scene is a professional kitchen environment.

we
grill

Charcoal Ovens

Hornos de brasa / Four à braise

Charcoal ovens

**Designed and
manufactured entirely
by Pujadas in high quality
stainless steel.**

**Perfect for indoor, open or
outdoor kitchens.**

*Diseñado y fabricado íntegramente por Pujadas en acero
inoxidable de máxima resistencia y calidad.*

*Perfecto para cualquier tipo de cocinas: interiores,
abiertas o exteriores.*

Conçu et fabriqué entièrement par Pujadas en acier
inoxydable haute résistance et qualité.

Idéal pour tout type de cuisine : intérieures, ouvertes ou
extérieures.

Three sizes available: 50, 90 and 140 diners.

*Tres tamaños disponibles: 50, 90 y 140 comensales.
Trois formats disponibles : 50, 90 et 140 convives.*

**Thermally insulated body for greater
efficiency and better protection from the
outside.**

*Cuerpo revestido con aislamiento térmico para una mayor
eficiencia y una mejor protección hacia el exterior.
Corps avec revêtement thermique pour une plus grande
efficacité et une meilleure protection vers l'extérieur.*

Available with black, red or stainless steel.

*Disponibles en negro, rojo o acero inoxidable.
Disponibles en noir, rouge ou acier inoxydable.*

Ash drawer.

*Cajón recogecenizas.
Tiroir à cendres.*



Double security firewalls for increased safety.

Doble cortafuegos de seguridad dobles para mayor protección.
Deux pare-feu de sécurité pour une plus grande protection.

Upper and lower airflow regulators ensure easy temperature control.

Reguladores de flujo de aire, superior e inferior, que garantizan un fácil control de la temperatura.
Les régulateurs de débit d'air, en haut et en bas, assurent un contrôle facile de la température.

High resistance and easy opening door system.

Puerta de alta resistencia y fácil apertura.
Porte de haute résistance et d'ouverture facile.

Adjustable grill height allows impressive versatility.

Parrilla ajustable en altura.
Grille réglable en hauteur.

Sunken charcoal fire bowl offers more space and easier operation.

Tolva de carbón hundida para un mayor espacio interior.
Trémie à charbon abaissée pour plus d'espace intérieur.



Technical info page 66

Info técnica pág. 66

Info techniques page 66

Oven operation

Funcionamiento horno
Fonctionnement du four

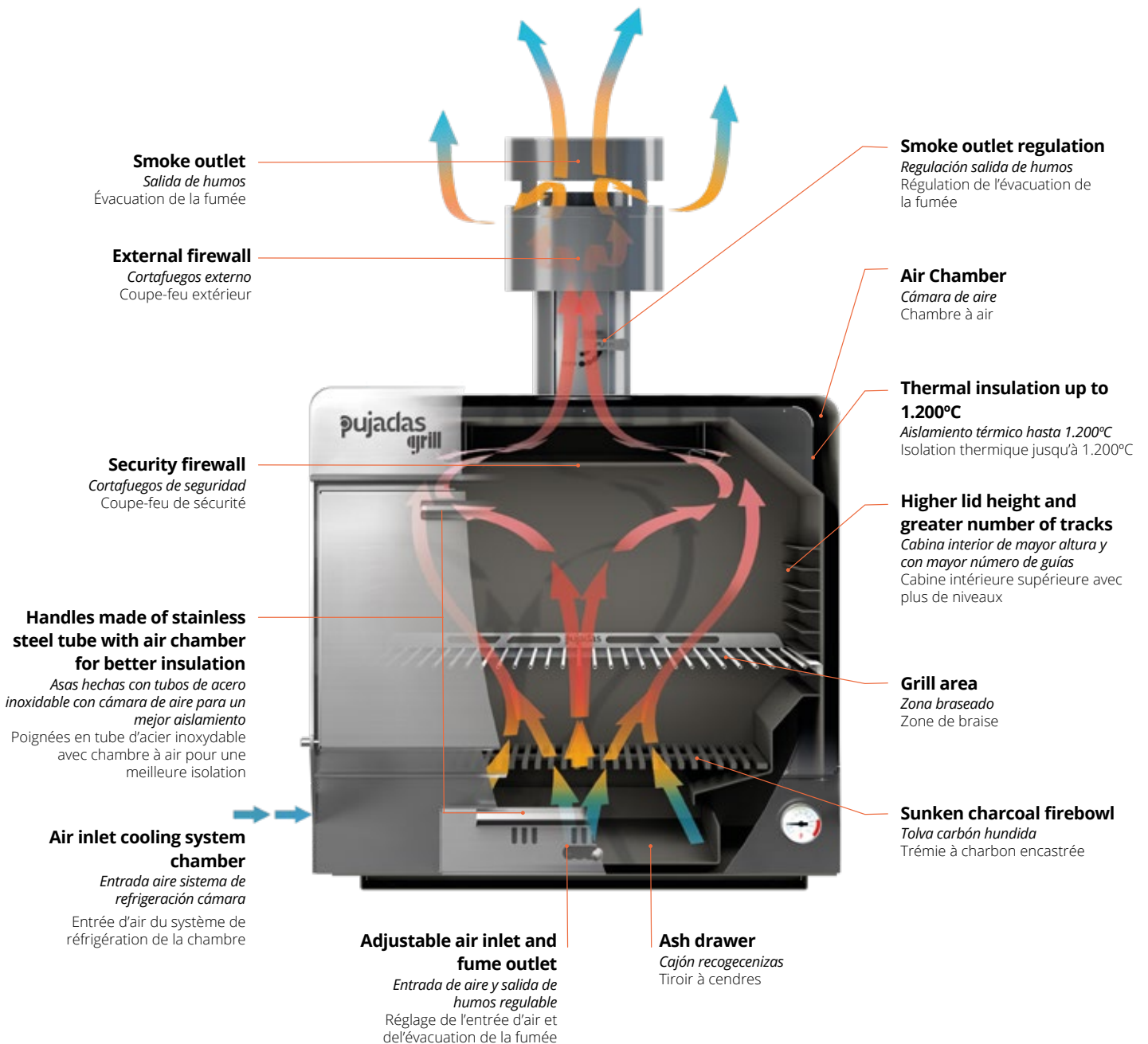

Charcoal Ovens

Hornos de brasa
Fours à braise

Charcoal Oven 50





Horno de brasa 50
Four à braise 50



40 - 50
diners
comensales
couverts



Technical info page 66
Info técnica pág. 66
Info techniques page 66

| REF | Dimensions Dimensiones Dimensions cm (W x D x H) | Colour Color Couleur | € / u |  |
|----------|---|---|----------|---|
| P85050SS | |  | 7.110,30 | |
| P85050R | 69x57x62 |  | 6.913,30 | 1 |
| P85050B | |  | 6.913,30 | |

Each oven comes with / Cada horno viene con / Chaque four est livré avec



Charcoal Ovens

Hornos de brasa
Fours à braise



Charcoal Oven 90

Horno de brasa 90
Four à braise 90



80 - 90
diners
comensales
couverts



| REF | Dimensions Dimensiones Dimensions cm (W x D x H) | Colour Color Couleur | € / u |  |
|----------|---|---|----------|---|
| P85090SS | |  | 8.252,10 | |
| P85090R | 69x66x72 |  | 7.888,30 | 1 |
| P85090B | |  | 7.888,30 | |

 **Technical info page 67**
Info técnica pág. 67
Info techniques page 67

Each oven comes with / Cada horno viene con / Chaque four est livré avec



Charcoal Ovens

Hornos de brasa
Fours à braise

Charcoal Oven 140

Horno de brasa 140
Four à braise 140



130 - 140
diners
comensales
couverts



 **Technical info page 68**
Info técnica pág. 68
Info techniques page 68

| REF | Dimensions Dimensiones Dimensions cm (W x D x H) | Colour Color Couleur | € / u |  |
|----------|---|---|----------|---|
| P85140SS | |  | 9.810,00 | |
| P85140R | 87x86x87 |  | 9.430,50 | 1 |
| P85140B | |  | 9.430,50 | |

Charcoal Ovens

Hornos de brasa
Fours à braise



Essentials

Esenciales
Esenciales

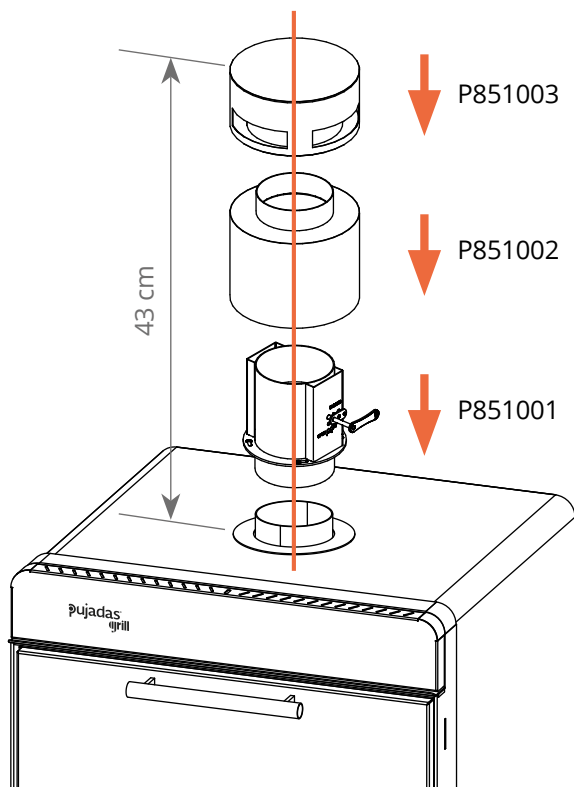

Hat filter
Filtro sombrero
Filtre chapeau supérieur



| REF | Ø cm | H cm | €/u |  |
|----------------|------|------|--------|---|
| P851003 | 25 | 12 | 232,80 | 1 |

Upper air flow regulator
Regulador de tiro superior
Régulateur de sortie de fumée



| REF | Ø cm | H cm | €/u |  |
|----------------|------|------|--------|---|
| P851001 | 15,4 | 23 | 368,50 | 1 |

External cutter flame
Cortafuegos externo
Coupe-feu externe



| REF | Ø cm | H cm | €/u |  |
|----------------|------|------|--------|---|
| P851002 | 25 | 23,8 | 372,30 | 1 |



Charcoal Ovens

Hornos de brasa
Fours à braise

Tables

Mesas
Tablas



Oven table - Oven 90
Mesa para horno Oven 90
Table pour four Oven 90



P85090MP



P85090MT



Available with wheels
Disponibile con ruedas
Disponible avec roues

Oven table - Oven 140
Mesa para horno Oven 140
Table pour four Oven 140



P85140MP



P85140MT



Available with wheels
Disponibile con ruedas
Disponible avec roues

| REF | w/wheels con ruedas avec roues | cm W x D x H | €/ u | ☐ |
|-----------|--------------------------------------|--------------------|----------|---|
| P85090MT | – | 68,5 x 56,5 x 85 | 857,00 | 1 |
| P85090MP | – | 68,5 x 60,8 x 85 | 2.034,05 | 1 |
| P85090MTR | • | 68,5 x 56,5 x 93,5 | 1.002,55 | 1 |
| P85090MPR | • | 68,5 x 60,8 x 93,5 | 2.232,60 | 1 |

| REF | w/wheels con ruedas avec roues | cm W x D x H | €/ u | ☐ |
|-----------|--------------------------------------|--------------------|----------|---|
| P85140MT | – | 94,5 x 80,5 x 70 | 1.033,70 | 1 |
| P85140MP | – | 94,5 x 84,7 x 70 | 2.231,85 | 1 |
| P85140MTR | • | 94,5 x 80,5 x 78,4 | 1.158,15 | 1 |
| P85140MPR | • | 94,5 x 84,7 x 78,4 | 2.372,50 | 1 |



pujadas

VOLLRATH





Open Grills

Brasas abiertas / Grills ouverts

Open grill

Designed and manufactured entirely by Pujadas in high quality stainless steel.

Perfect for indoor, open or outdoor kitchens.

Diseñado y fabricado íntegramente por Pujadas en acero inoxidable de máxima resistencia y calidad.

Perfecto para cualquier tipo de cocinas: interiores, abiertas o exteriores.

Conçu et fabriqué entièrement par Pujadas en acier inoxydable haute résistance et qualité.

Idéal pour tout type de cuisine : intérieures, ouvertes ou extérieures.

Tempering grill and bar.

Parrilla y barra atemperadoras.
Grille et barre pour rémise en température.

Large cooking surface available with V-shaped and rod bar grills.

Ámplia superficie de cocción, disponible con parrillas en V y con varillas.
Grande surface de cuisson disponible avec grille en V ou en fil rond.

Refractory brick base.

Base de ladrillo refractario.
Base en brique réfractaire.

Thermally insulated body for greater efficiency and better protection from the outside.

Cuerpo revestido con aislamiento térmico para una mayor eficiencia y una mejor protección hacia el exterior.
Corps avec revêtement thermique pour une plus grande efficacité et une meilleure protection vers l'extérieur.

2 shelves.

2 estantes.
2 étagères.



Tilting grill in three positions: charcoal lighting, flat for cookware, fat collecting.

Parrilla vasculante con tres posiciones: atizar carbón, cocinar con menaje, recoger grasa.
Grille inclinable en trois positions : allumage du charbon, cuisson avec batterie, récupération des graisses.

NEW



Handwheel for easy elevation up to 400 mm.

Elevación regulable mediante volante hasta 400 mm.
Élévation réglable par volant jusqu'à 400 mm.

Available with black, red or stainless steel.

Disponibile en negro, rojo y acero inoxidable.
Disponible en noir, rouge ou acier inoxydable.

Grease collector.

Recogedor de grasa.
Collecteur de graisse.

GN 1/1 rails.

Guías GN 1/1
Glissières GN 1/1

Front wheels with brakes.

Ruedas delanteras con frenos.
Roulettes avant avec freins.

 **Technical info page 69-70**
Info técnica pág. 69-70
Info techniques page 69-70

Open Grills

Brasas abiertas
Grills ouverts



Open grill

Brasa abierta
Grill ouvert



| REF | Colour Color Couleur | Grill Parrilla Grill | € / u | |
|------------|----------------------------|----------------------------|--------|---|
| P8581010R | ● | ○ | 13.645 | 1 |
| P8581011R | ● | ∇ | 13.645 | 1 |
| P8581010B | ● | ○ | 13.645 | 1 |
| P8581011B | ● | ∇ | 13.645 | 1 |
| P8581010SS | ● | ○ | 13.645 | 1 |
| P8581011SS | ● | ∇ | 13.645 | 1 |

Technical info page 69
Info técnica pág. 69
Info techniques page 69



Available with adjustable feet.
Disponible con pies regulables.
disponible avec pieds réglables en hauteur.



V shape grill
Parilla en V
Grille en V

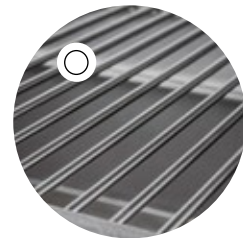

Rod bar grill
Parrilla con varillas
Grille ronde

Each open grill comes with / Cada brasa abierta viene con / Chaque grill ouvert est livré avec



Open Grills

Brasas abiertas
Grills ouverts

Countertop Open grill

Brasa abierta de sobremesa
Grill ouvert de table

| REF | Colour Color Couleur | Grill Parrilla Grill | € / u |  |
|------------|----------------------------|----------------------------|--------|---|
| P8581000R | ● | ○ | 10.923 | 1 |
| P8581001R | ● | ∇ | 10.923 | 1 |
| P8581000B | ● | ○ | 10.923 | 1 |
| P8581001B | ● | ∇ | 10.923 | 1 |
| P8581000SS | ● | ○ | 10.923 | 1 |
| P8581001SS | ● | ∇ | 10.923 | 1 |

 **Technical info page 69**
Info técnica pág. 69
Info techniques page 69



Open grill without refractory base

Brasa abierta sin base refractaria
Grill ouvert sans base réfractaire

| REF | Colour Color Couleur | Grill Parrilla Grill | € / u |  |
|------------|----------------------------|----------------------------|-------|---|
| P8581030R | ● | ○ | 8.010 | 1 |
| P8581031R | ● | ∇ | 8.010 | 1 |
| P8581030B | ● | ○ | 8.010 | 1 |
| P8581031B | ● | ∇ | 8.010 | 1 |
| P8581030SS | ● | ○ | 8.010 | 1 |
| P8581031SS | ● | ∇ | 8.010 | 1 |

 **Technical info page 70**
Info técnica pág. 70
Info techniques page 70



Anchors for fixing
Anclajes para fijación
Ancrages pour la fixation

Install on refractory brick base
Instalar sobre base de ladrillo refractario
Installer sur une base en brique réfractaire

Open grill

Designed and manufactured entirely by Pujadas in high quality stainless steel.

Perfect for indoor, open or outdoor kitchens.

Diseñado y fabricado íntegramente por Pujadas en acero inoxidable de máxima resistencia y calidad.

Perfecto para cualquier tipo de cocinas: interiores, abiertas o exteriores.

Conçu et fabriqué entièrement par Pujadas en acier inoxydable haute résistance et qualité.

Idéal pour tout type de cuisine : intérieures, ouvertes ou extérieures.

Built-in firebasket (optional).

Leñero quemador incorporado. (opcional).
Brûleur à bois intégré (optionnel).

Independent double open grill with 5 cooking levels. Available with V-shaped and rod bar grills

Dos superficies de cocción independientes. Disponibles con parrilla en V o varillas.
Deux surfaces de cuisson indépendantes. Disponible avec grille en V ou en fil rond.

Grease collectors

Recogedores de grasa
Collecteurs de graisse

Available with black, red or stainless steel

Disponible en negro, rojo y acero inoxidable
Disponible en noir, rouge ou acier inoxydable

2 shelves.

2 estantes.
2 étagères.



Tilting grill in three positions: charcoal lighting, flat for cookware, fat collecting.

Parrilla vasculante con tres posiciones: atizar carbón, cocinar con menaje, recoger grasa.

Grille inclinable en trois positions : allumage du charbon, cuisson avec batterie, récupération des graisses.

lite

NEW



Tempering bar

Barra de atemperamiento
Barre pour remise en température.

Refractory brick base.

Base de ladrillo refractario.
Base en brique réfractaire.

GN 1/1 rails.

Guías GN 1/1
Glissières GN 1/1

Front wheels with brakes.

Ruedas delanteras con frenos.
Roulettes avant avec freins.

 **Technical info page 70-71**
Info técnica pág. 70-71
Info techniques page 70-71

Open grill lite

Brasa abierta lite
Grill ouvert lite



Open grill lite

Brasa abierta lite
Grill ouvert lite



| REF | Colour Color Couleur | Num. fire baskets Núm. leñeros Num. brûleurs | Grill Parrilla Grill | € / u | |
|------------|----------------------------|--|----------------------------|--------|---|
| P8583010R | ● | 2 | ○ | 11.345 | 1 |
| P8583011R | ● | 2 | ∇ | 11.345 | 1 |
| P8583010B | ● | 2 | ○ | 11.345 | 1 |
| P8583011B | ● | 2 | ∇ | 11.345 | 1 |
| P8583010SS | ● | 2 | ○ | 11.345 | 1 |
| P8583011SS | ● | 2 | ∇ | 11.345 | 1 |
| P8583110R | ● | 1 | ○ | 11.133 | 1 |
| P8583111R | ● | 1 | ∇ | 11.133 | 1 |
| P8583110B | ● | 1 | ○ | 11.133 | 1 |
| P8583111B | ● | 1 | ∇ | 11.133 | 1 |
| P8583110SS | ● | 1 | ○ | 11.133 | 1 |
| P8583111SS | ● | 1 | ∇ | 11.133 | 1 |
| P8583210R | ● | 0 | ○ | 10.921 | 1 |
| P8583210B | ● | 0 | ∇ | 10.921 | 1 |
| P8583211B | ● | 0 | ○ | 10.921 | 1 |
| P8583210SS | ● | 0 | ∇ | 10.921 | 1 |
| P8583211SS | ● | 0 | ○ | 10.921 | 1 |
| P8583221SS | ● | 0 | ∇ | 10.921 | 1 |

Technical info page 70
Info técnica pág. 70
Info techniques page 70

Available with adjustable feet.
Disponible con pies regulables.
disponible avec pieds réglables en hauteur.



V shape grill
Parilla en V
Grille en V

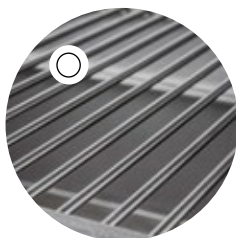

Rod bar grill
Parrilla con varillas
Grille ronde



Fire basket to burn wood
Leñero para quemar madera
Brûleur à bois

Each open grill lite comes with / cada brasa abierta lite viene con / chaque grill ouvert lite est livré avec



Open grill lite

Brasa abierta lite
Grill ouvert lite

SS
Stainless
steel

Countertop Open grill lite

Brasa abierta lite de sobremesa
Grill ouvert lite de table

| REF | Colour Color Couleur | Num. fire baskets Núm. leñeros Num. brûleurs | Grill Parrilla Grill | € / u |  |
|------------|----------------------------|--|----------------------------|-------|---|
| P8583000R | ● | 2 | ○ | 8.810 | 1 |
| P8583001R | ● | 2 | ∇ | 8.810 | 1 |
| P8583000B | ● | 2 | ○ | 8.810 | 1 |
| P8583001B | ● | 2 | ∇ | 8.810 | 1 |
| P8583000SS | ● | 2 | ○ | 8.810 | 1 |
| P8583001SS | ● | 2 | ∇ | 8.810 | 1 |
| P8583100R | ● | 1 | ○ | 8.598 | 1 |
| P8583101R | ● | 1 | ∇ | 8.598 | 1 |
| P8583100B | ● | 1 | ○ | 8.598 | 1 |
| P8583101B | ● | 1 | ∇ | 8.598 | 1 |
| P8583100SS | ● | 1 | ○ | 8.598 | 1 |
| P8583101SS | ● | 1 | ∇ | 8.598 | 1 |
| P8583200R | ● | 0 | ○ | 8.386 | 1 |
| P8583201R | ● | 0 | ∇ | 8.386 | 1 |
| P8583200B | ● | 0 | ○ | 8.386 | 1 |
| P8583201B | ● | 0 | ∇ | 8.386 | 1 |
| P8583200SS | ● | 0 | ○ | 8.386 | 1 |
| P8583201SS | ● | 0 | ∇ | 8.386 | 1 |



 **Technical info page 71**
Info técnica pág. 71
Info techniques page 71

Open grill lite without refractory base

Brasa abierta lite sin base refractaria
Grill ouvert lite sans base réfractaire

| REF | Colour Color Couleur | Num. fire baskets Núm. leñeros Num. brûleurs | Grill Parrilla Grill | € / u |  |
|------------|----------------------------|--|----------------------------|-------|---|
| P8583030SS | ● | 2 | ○ | 6.685 | 1 |
| P8583031SS | ● | 2 | ∇ | 6.685 | 1 |
| P8583130SS | ● | 1 | ○ | 6.473 | 1 |
| P8583131SS | ● | 1 | ∇ | 6.473 | 1 |
| P8583230SS | ● | 0 | ○ | 6.261 | 1 |
| P8583231SS | ● | 0 | ∇ | 6.261 | 1 |

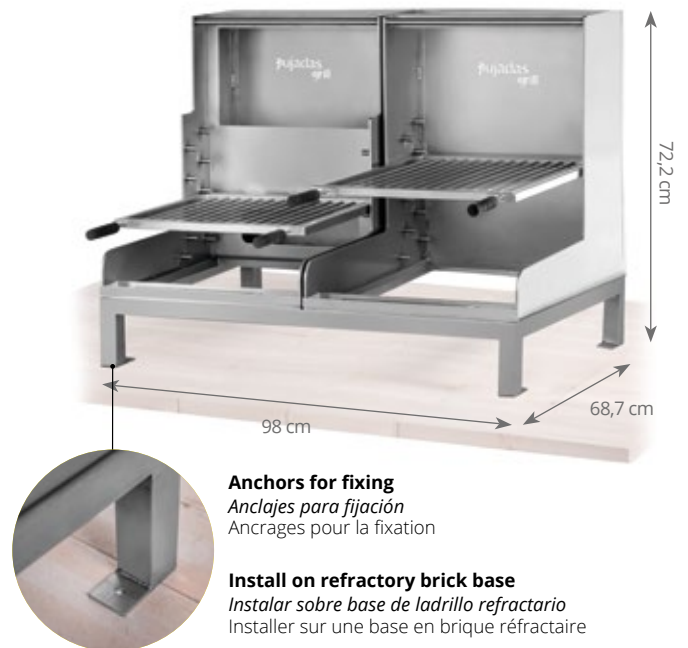

Anchors for fixing
Anclajes para fijación
Ancrages pour la fixation

Install on refractory brick base
Instalar sobre base de ladrillo refractario
Installer sur une base en brique réfractaire

 **Technical info page 71**
Info técnica pág. 71
Info techniques page 71

Robata

Designed and manufactured entirely by Pujadas in high quality stainless steel.

Perfect for kitchens with limited space.

Diseñado y fabricado íntegramente por Pujadas en acero inoxidable de máxima resistencia y calidad.

Perfecta para cocinas con espacio limitado.

Conçu et fabriqué entièrement par Pujadas en acier inoxydable haute résistance et qualité.

Idéal pour cuisines avec un espace limité.



With 5 movable racks for all types of cooking.

Con 5 rejillas movibles para cualquier tipo de cocción.
Avec 5 grilles amovibles pour tout type de cuisson.

Removable 65 mm GN 2/3 container, for all types of cooking.

Cubeta GN 2/3 de 65 mm movable, para cualquier tipo de cocción.
Bac GN 2/3 65 mm mobile, pour tout type de cuisson.

2 removable rod grills, ideal for intense embers.

2 parrillas de varilla removibles, ideal para brasa intensa
2 grilles à tiges amovibles, idéales pour la braise intense.

5 100 mm GN 1/9 containers for ingredients

5 cubetas GN inox 1/9 100 mm para ingredientes.
5 bacs GN inox 1/9 100 mm pour ingrédients.

2 shelves.

2 estantes.
2 étagères.

Front wheels with brakes.

Ruedas delanteras con frenos.
Roulettes avant avec freins.



NEW



Open grill with 3 cooking levels.

*Parrilla abierta con 3 niveles de cocción.
Grill ouvert avec 3 niveaux de cuisson.*

Available with black, red or stainless steel.

*Disponible en negro, rojo y acero inoxidable.
Disponible en noir, rouge ou acier inoxydable*

Refractory brick base.

*Base de ladrillo refractario.
Base en brique réfractaire.*

GN 1/1 rails.

*Guías GN 1/1
Glissières GN 1/1*









Technical info page 72
*Info técnica pág. 72
Info techniques page 72*



pujadas

Robata

| REF | Colour Color Couleur | Grill Parrilla Grill | € / u |  |
|------------|---|---|-------|---|
| P8582010R |  |  | 7.852 | 1 |
| P8582010B |  |  | 7.852 | 1 |
| P8582010SS |  |  | 7.852 | 1 |

 **Technical info page 72**
Info técnica pág. 72
 Info techniques page 72









Available with adjustable feet.
Disponibile con pies regulables.
 disponible avec pieds réglables en hauteur.



Countertop Robata

Robata de sobremesa
 Robata de table

| REF | Colour Color Couleur | Grill Parrilla Grill | € / u |  |
|------------|---|---|-------|---|
| P8582000R |  |  | 5.115 | 1 |
| P8582000B |  |  | 5.115 | 1 |
| P8582000SS |  |  | 5.115 | 1 |

 **Technical info page 72**
Info técnica pág. 72
 Info techniques page 72



Each robata comes with / *Cada robata viene con* / *Chaque robata est livré avec*



x5



Only with table version
Solo con la versión con mesa
 Uniquement avec la version avec table



Grillbox



Grillbox



Grillbox

Just the way you like it

A tu gusto, a tu ritmo

À votre goût, à votre rythme

**Designed and
manufactured
entirely by Pujadas
in high quality
stainless steel.**

Diseñada y fabricada íntegramente por Pujadas en acero inoxidable de alta resistencia y calidad.

Conçu et fabriqué entièrement par Pujadas en acier inoxydable haute résistance et qualité.



High-quality stainless steel mini grill.

*Mini parrilla acero inox de alta calidad.
Mini grill acier inox de haute qualité.*

Charcoal container.

*Carbonera.
Espace charbon.*

**High-quality stainless steel reinforced casing.
Prevents heat leakage during preparation.**

*Carcasa reforzada acero inox de alta calidad.
Impide la fuga de calor durante la preparación.
Carcasse renforcée en acier inoxydable de haute qualité.
Empêche la perte de chaleur pendant la préparation.*

**High-quality stainless-steel base.
Low weight for easy transport.**

*Base de acero inox de alta calidad.
Peso reducido para facilitar su transporte.
Base en acier inoxydable de haute qualité.
Poids léger pour faciliter son transport.*

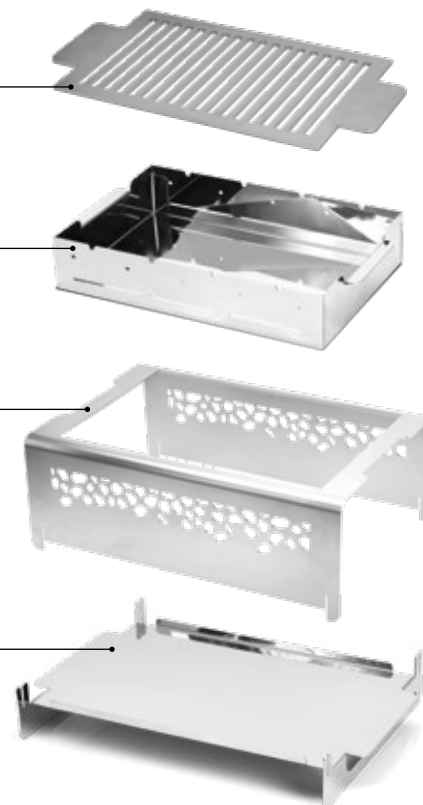



Grillbox

Stainless steel tabletop barbecue

Barbacoa sobremesa acero inox
Barbecue de table acier inox



| REF | W x D x H cm | € / u | |
|--------|--------------|--------|---|
| P85200 | 37 x 26 x 15 | 254,30 | 1 |

Stainless Steel tabletop barbecue Duo

Barbacoa de sobremesa Duo acero inoxidable
Barbecue de table Duo en acier inoxydable

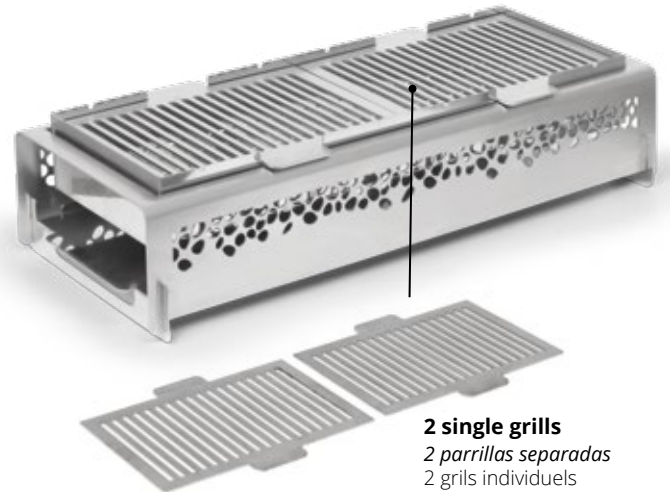

2 single grills
2 parrillas separadas
2 grills individuels

| REF | W x D x H cm | € / u | |
|--------|--------------|--------|---|
| P85220 | 66 x 26 x 15 | 397,00 | 1 |

Stainless steel tray

Llauna inox
Plaque inox



| REF | W x D x H cm | € / u | |
|----------|-----------------|-------|---|
| P2960001 | 29,3 x 19,3 x 2 | 19,15 | 1 |

Basalt stone

Piedra de basalto
Pierre de basalte



| REF | W x D x H cm | € / u | |
|--------|-----------------|-------|---|
| P85201 | 28,7 x 18,7 x 2 | 25,95 | 1 |

Skewer

Pincho
Brochette



12 units box
Caja 12 unidades
Colis 12 unités

| REF | L cm | € / u | |
|---------|------|-------|---|
| P968130 | 30 | 8,05 | 1 |

Gripper

Pala
Pelle



| REF | L cm | € / u | |
|--------|------|-------|----|
| P85223 | 30 | 19,50 | 12 |



A close-up photograph of a chef in a white uniform, focused on a task. The chef's hands are in the foreground, holding two pairs of chopsticks. One pair is silver and the other is dark wood. The chef is positioned over a dark plate on a wooden table. The background is blurred, showing a restaurant interior with warm lighting and other diners. The overall mood is professional and precise.

Smoker

Ahumador / Fumoir

Smoker

Ahumador
Fumoir



Smoker

Highly resistant to large-scale work volumes

Altamente resistente a grandes volúmenes de trabajo

Très résistante aux grands volumes de travail

Smoker

Ahumador
Fumoir

Smoking Valve

Válvula para aromatizar
Vanne aromatisante



Tank for burner

Depósito para quemador
Réservoir pour brûleur

Support for the Gun

Soporte para el aromatizador
Support pour l'aromatiseur

Burner

Quemador con mini rejilla incluida,
y con recambios
Brûleur

The smoking technique is a growing trend not only for the culinary preparations of the most prestigious chefs but also for all those who prioritize innovation and originality in their menus.

Easily, quickly and efficiently achieve totally cold smoke, much more aromatic and stable over time, and suitable for sauces, oils, meats, fish, cheeses, rice dishes or even cocktails.

La técnica del ahumado es una tendencia al alza no sólo para las elaboraciones culinarias de los más prestigiosos chefs sino de todos aquellos que priman la innovación y originalidad en sus preparaciones.

Consigue humos totalmente fríos, mucho más aromáticos y estables en el tiempo para tus salsas, aceites, carnes, pescados, quesos, arroces o incluso cocktails de manera fácil, rápida y eficaz.

La technique du fumage est une tendance à la hausse non seulement pour les élaborations culinaires des chefs les plus prestigieux, mais aussi pour tous ceux qui privilégient l'innovation et l'originalité dans leurs préparations.

Obtenez des fumées totalement froides, beaucoup plus aromatiques et stables dans le temps pour vos sauces, huiles, viandes, poissons, fromages, riz ou même cocktails de façon facile, rapide et efficace.

PUJADAS KITCHENWARE for smoking and flavouring

Menaje Pujadas para ahumar y aromatizar

Ustensiles de cuisine Pujadas pour fumer et aromatiser

Food silicone valves with self-closing system that allow the entry of flavoured smoke without leaks, and preserving all food essence.

Válvulas de silicona alimentaria con autocierre que permiten la entrada del humo aromatizado sin fugas/escapes, preservando toda su esencia.

Valves en silicone alimentaire à fermeture automatique qui permettent l'entrée de fumée aromatisée sans fuites / pertes, préservant toute son essence.



Smoker

Ahumador
Fumoir

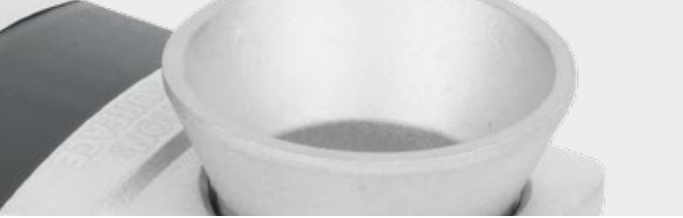

Smoker

Ahumador
Fumoir



| REF | W x D x H cm | € / u | |
|--------|-----------------|-------|---|
| P85230 | 5,5 x 12,5 x 16 | 73,60 | 1 |

GN hermetic lid for smoking

Tapa hermética GN para ahumar
Couvercle hermétique GN pour fumer

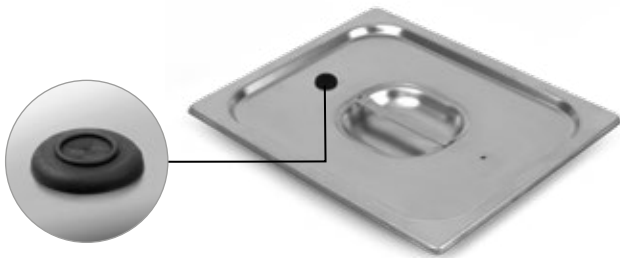

| REF | GN | cm | € / u | |
|----------|-----|-------------|-------|---|
| P110004A | 1/1 | 53 x 32,5 | 68,10 | 1 |
| P120004A | 1/2 | 32,5 x 26,5 | 59,55 | 1 |

Ideal for cold smoking large pieces of meat or whole fish. Adaptable to all 1/1 & 1/2 GN containers.

Ideal para ahumar en frío piezas grandes de carne y pescado enteras. Adaptable a todas las cubetas GN 1/1 y 1/2.

Idéal pour fumer à froid de gros morceaux de viande ou poisson entier. Adaptable à Tous les bacs GN 1/1 et 1/2.

Cookware inox lid for smoke

Tapa batería inox para ahumar
Couvercle de batterie en acier inoxydable pour fumer



| REF | Ø cm | € / u | |
|----------|------|-------|---|
| P209020A | 20 | 18,95 | 1 |
| P209024A | 24 | 20,00 | 1 |
| P209028A | 28 | 23,55 | 1 |
| P209032A | 32 | 25,70 | 1 |

Lid with smoke valve for preparations such as sauces, stews, etc.

Tapa con válvula de ahumado para elaboraciones como salsas, cocidos, etc.

Couvercle avec valve de fumage pour les élaborations telles que les sauces, les ragoûts, etc.

Chips beech and oak

Chips aroma haya y roble

Chips d'arôme de hêtre et de chêne



P85232



P85231

| REF | Ø cm | H cm | gr | € / u | |
|--------|------|------|----|-------|---|
| P85231 | 7,5 | 9 | 80 | 5,45 | 1 |
| P85232 | 7,5 | 9 | 80 | 6,05 | 1 |





Charcoal

Carbón / Charbon



Charcoal

Carbón
Charbon



Charcoal top quality Marabú

Carbón vegetal Marabú primera calidad
Charbon de bois Marabú de qualité supérieure

- High calorific performance.
- A good mix of lumpwood and broken charcoal pieces.
- Coarse-grained, dust-free charcoal.
- 10 Kg bag with handle for easy transport and handling.
- Bag made of plasticized raffia to prevent soot from escaping.

- Alto rendimiento calorífico.
- Buena mezcla de roturado y canelino.
- Carbón de granulometría gruesa y sin polvo.
- Saco de 10 kg con asa para su fácil transporte y manejo.
- Saco fabricado en rafia plastificada para evitar el escape de hollín.

- Puissance calorifique élevée.
- Bonne proportion de roturado et canelino.
- Charbon grosse granulométrie et sans poussière.
- Sac de 10 kg avec poignée pour un transport et une manipulation faciles.
- Sac fabriqué en raphia plastifié pour éviter la perte de suie.

Sale unit: 1 pallet
including 28 10Kg charcoal bags

Unidad de venta: 1 palet
28 sacos de 10Kg. de carbón

Unité de vente: 1 palette
28 sacs de 10Kg. de
charbon de bois



| REF | Wood type Tipo de madera Type de bois | Calorific value Poder calorífico Puissance calorifique Kcal/Kg | Granulometry Granulometría Granulométrie mm | Carbon Carbono Carbone % | Ashes Cenizas Cendres % | Humidity Humedad Humidité % | Density Densidad Densité Km/m ³ | Bag weight Peso saco Poids sac Kg |
|---------|---|---|--|-----------------------------------|----------------------------------|--------------------------------------|---|--|
| P850000 | Marabú | ≈ 8000 | 150 | > 75 | < 5 | < 6 | 298 | 10 |

Comparison of consumption according to energy source

Comparativa de consumo según fuente energética / Comparaison des consommations selon la source d'énergie

| OVEN TYPE TIPO HORNO TYPE FOUR | Dimensiones Dimensions Dimensions cm (H x W x D) | Power Potencia Puissance KW | Consumption Consumo Consommation | Cost Gasto Dépense €/ hour / hora / heure | Difference Diferencia Différence PJD OVEN 90 | Difference Diferencia Différence PJD OVEN 140 |
|--|---|--------------------------------------|--|--|---|--|
| ELECTRIC ELÉCTRICO ÉLECTRIQUE | 80 x 90 x 68 | 6 | 6 KW/h | 1,01 | -36% | -10% |
| GAS GAS GAZ | 80 x 90 x 68 80 x 73 x 60 80 x 86 x 62 | 8 | 0,85 m ³ | 1,12 | -42% | -19% |
| CHARCOAL CARBÓN À BRAISE OVEN 90 | 69 x 66 x 72 | 10,8 (Marabú) | 5 kg / 4h | 0,65 | - | - |
| CHARCOAL CARBÓN À BRAISE OVEN 140 | 87 x 88 x 87 | 15,1 (Marabú) | 7 Kg / 4h | 0,91 | -29% | - |

Charcoal

Carbón
Charbon

Oak chunks

Tacos de madera de roble
Morceaus de chêne



| REF | Kg | € / u | |
|---------|-----|-------|---|
| P850101 | ± 4 | 41,45 | 1 |

Sherry aromatic oak chips

Astillas de roble con aroma fino
Copeaux de chêne à l'arôme de xérès



Chips from authentic macerated barrel
Astillas de auténtica barrica macerada
Copeaux d'authentiques barriques macérées

| REF | Kg | € / u | |
|---------|-----|-------|---|
| P850102 | ± 2 | 36,35 | 1 |

Whisky aromatic oak chips

Astillas de roble con aroma whisky
Copeaux de chêne à l'arôme de whisky



Chips from authentic macerated barrel
Astillas de auténtica barrica macerada
Copeaux d'authentiques barriques macérées

| REF | Kg | € / u | |
|---------|-----|-------|---|
| P850104 | ± 2 | 36,35 | 1 |

100% natural

100% natural / 100 % naturel

Add subtle nuances and aromas to your recipes with the age-old technique of smoking. Aromatize the embers before starting with the elaboration so your dishes will get new tastes.

Agrega sutiles matices y aromas a tus recetas con la técnica milenaria del ahumado. Aromatiza la brasa antes de empezar con la elaboración, así tus platos conseguirán nuevos sabores que sorprenderán.

Ajoutez des nuances et des arômes subtils à vos recettes grâce à la technique ancestrale du fumage. Parfumez les braises avant de commencer la cuisson, de cette façon vos plats obtiendront de nouveaux arômes et goûts.

Calculations may vary according to the energy tariffs in different countries / Los cálculos pueden variar según las tarifas energéticas de los diferentes países / Les calculs peuvent varier en fonction du prix de l'énergie des différents pays.

- **Greater power and efficiency. A way to cook faster, cleaner and healthier.**
- **No need to connect to a power source.**
- **Depending on the number of services, improves the energy cost.**
- **The high calorific value of charcoal increases its efficiency: with a small amount of charcoal, the temperature increases quickly and reaches a point suitable for cooking in less than 10 minutes.**
- **Allows you to control the cooking temperature thanks to the upper and lower air flow regulators.**
- **Fast return on investment (2.5 years approximately).**
- *Mayor potencia y eficiencia. Una forma de cocinar más rápida, limpia y saludable.*
- *No es necesario conectar a la corriente.*
- *Según el número de servicios, mejora el coste de la energía.*
- *El alto poder calorífico del carbón incrementa su eficiencia: con poca cantidad de carbón aumenta la temperatura rápidamente y llega al punto apto para cocción en menos de 10 minutos.*
- *Permite controlar la temperatura de cocción gracias a los reguladores de caudal de aire superior e inferior.*
- *Rápido retorno de la inversión (2,5 años aproximadamente).*
- *Puissance et efficacité accrues. Une façon de cuisiner plus rapide, plus propre et plus saine.*
- *La connexion à l'alimentation n'est pas nécessaire.*
- *Selon le nombre de services, réduit la dépense énergétique.*
- *Le haut pouvoir calorifique du charbon augmente son efficacité : une petite quantité de charbon suffit pour augmenter la température rapidement et atteindre le point de cuisson approprié en moins de 10 minutes.*
- *Permet de contrôler la température de cuisson grâce aux régulateurs de débit d'air supérieur et inférieur.*
- *Retour sur investissement rapide (2,5 ans environ).*



Accessories

Accesorios / Accessoires

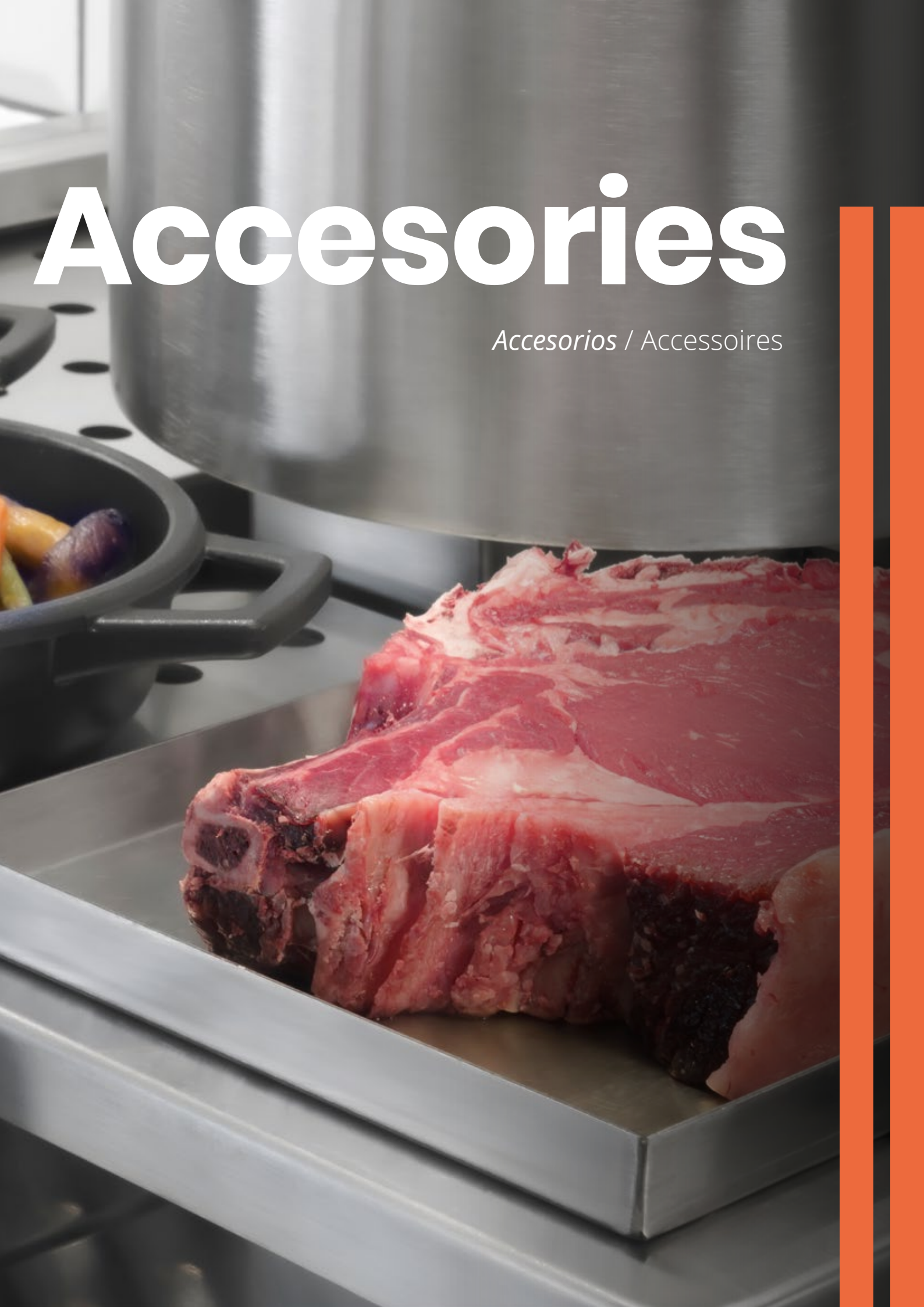

Accessories

Accesorios
Accessoires



Stainless Steel hot plate

Parrilla calentaplatos acero inox

Grille chauffer acier inox

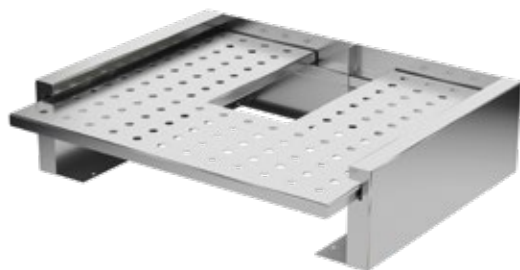

Stainless steel charcoal oven rack

Parrilla varilla inox horno brasa

Grille four à braise en acier inoxydable



| REF | Oven Horno Four | W x D x H cm | € / u | |
|-----------------|-----------------------|--------------------|--------|---|
| P85050CP | 50 | 67,7 x 46,6 x 18,4 | 437,45 | 1 |
| P85090CP | 90 | 67,7 x 56,6 x 18,4 | 475,25 | 1 |
| P85140CP | 140 | 86 x 74,6 x 18,4 | 611,35 | 1 |

| REF | Oven Horno Four | W x D x H cm | € / u | |
|-----------------|-----------------------|-----------------|--------|---|
| P8505004 | 50 | 58 x 36,7 x 2 | 384,05 | 1 |
| P8509007 | 90 | 58 x 46,7 x 2 | 472,30 | 1 |
| P8514007 | 140 | 76,6 x 64,8 x 2 | 502,25 | 1 |

Grill for Open Grill

Parrilla Open Grill

Grille Open Grill



Grill for Open Grill Lite

Parrilla para Open Grill Lite

Grille Open Grill Lite



| REF | W x D x H cm | Grill Parrilla Grill | € / u | |
|----------------|-----------------|----------------------------|--------|---|
| P858100 | 86,2 x 53,6 x 2 | ○ | 897,00 | 1 |
| P858101 | 86,2 x 53,6 x 2 | ∨ | 897,00 | 1 |

| REF | W x D x H cm | Grill Parrilla Grill | € / u | |
|-----------------|-----------------|----------------------------|--------|---|
| P858300* | 44,6 x 46,4 x 2 | ○ | 787,00 | 1 |
| P858301* | 44,6 x 46,4 x 2 | ∨ | 787,00 | 1 |
| P858310 | 58 x 46,4 x 2 | ○ | 793,00 | 1 |
| P858311 | 58 x 46,4 x 2 | ∨ | 793,00 | 1 |

* Suitable for firebasket

* Compatible con leñero

* Adaptable pour brûleur à bois

Accessories

Accesorios
Accessoires



Rod grill for Robata

Parrilla de varilla para Robata
Grille à tiges pour Robata



| REF | W x D cm | € / u | |
|---------|-----------|--------|---|
| P858200 | 44 x 35,7 | 460,80 | 1 |

Maintenance grill for robata. Pack 2u.

Rejilla mantenimiento para robata. Pack 2u.
Grille remise en temperature pour Robata. Pack 2u.

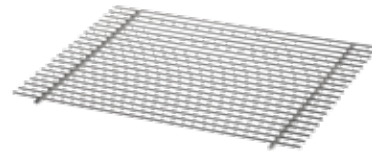

| REF | W x D cm | € / pack | |
|---------|----------|----------|---|
| P858210 | 37 x 30 | 156,30 | 1 |

GN 2/3 65 mm container

Cubeta GN 2/3 65 mm
Bac GN 2/3 65 mm



| REF | W x D x H cm | Lts | € / u | |
|---------|-------------------|-----|-------|---|
| P230651 | 35,5 x 32,5 x 6,5 | 5,6 | 25,45 | 6 |

Pack 5u. refractory bricks

Pack 5u. ladrillo refractario
Pack 5u. brique réfractaire



| REF | W x D x H cm | € / pack | |
|---------|--------------|----------|---|
| P858000 | 22 x 11 x 3 | 19,50 | 1 |

Accessories

Accesorios
Accessoires



Heavy duty oven tong

Pinza reforzada horno

Pince renforcée pour four



| REF | cm | € / u | |
|----------------|------|-------|-----|
| P851004 | 33,5 | 42,10 | 120 |

VERSAGRIP® Stainless steel tong

Pinza VERSAGRIP® de acero inoxidable

Pince inox VERSAGRIP®



Serrated edge to securely grip food

Borde dentado para un agarre seguro de los alimentos
Bord dentelé pour une prise sûre des aliments

| REF | L cm | € / u | |
|----------------|------|-------|----|
| 4791210 | 30,5 | 10,55 | 12 |
| 4791610 | 40,6 | 13,15 | 12 |

Stainless steel tong

Pinza de acero inoxidable

Pince inoxydable



Scalloped
Festoneada
Festonné

| REF | L cm | € / u | |
|----------------|------|-------|----|
| 4781210 | 30,5 | 10,55 | 12 |
| 4781610 | 40,6 | 13,25 | 12 |

Rost pan tong w/silicon protection

Pinza rustidera c/proteccion silicona

Pinze plaque a/protection silicone



| REF | L cm | € / u | |
|----------------|------|-------|-----|
| P607100 | 18 | 18,15 | 120 |

Roast pan tong

Pinza fuente horno

Pince pour plaque à rôtir



| REF | L cm | € / u | |
|----------------|------|-------|----|
| P607000 | 19 | 12,80 | 10 |

Accessories

Accesorios
Accessoires



Carry-skewers

Porta pinchos
Porte-brochettes



| REF | Ø cm | H cm | €/u | |
|---------|------|------|-------|---|
| P968000 | 22 | 46 | 37,05 | 1 |

Skewer

Pincho
Brochette



12 units box
Caja 12 unidades
Colis 12 unités

| REF | L cm | €/u | |
|---------|------|------|----|
| P968135 | 35 | 9,05 | 12 |

Oven poker

Pala atizadora
Tisonnier pour



| REF | W x D x H cm | €/u | |
|----------|---------------|-------|---|
| P851005S | 65 x 10 x 3,5 | 44,10 | 1 |
| P851005L | 85 x 10 x 3,5 | 46,70 | |

Collect ashes shovel

Pala recogecenizas
Pelle à cendres



| REF | W x D x H cm | €/u | |
|----------|--------------|-------|---|
| P851006S | 35 x 15 x 12 | 46,05 | 1 |
| P851006L | 54 x 15 x 20 | 52,60 | 1 |

Metallic brush

Cepillo metálico
Brosse métallique



| REF | L cm | €/u | |
|----------|------|-------|---|
| P851007 | 23,5 | 56,45 | 1 |
| RE851008 | 23,5 | 16,10 | 1 |

Metallic brush

Cepillo metálico
Brosse métallique



| REF | L cm | €/u | |
|---------|------|------|---|
| P818000 | 27 | 2,45 | 1 |





Cookware

Menaje / Batterie



Cookware

Menaje
Batterie



Black Series



Shallow casserole without lid

Cazuela baja sin tapa
Cocotte sans couvercle



Ground base
Fondo torneado
Fond dressé

| REF | Ø cm | H cm | Lts | €/u | |
|----------|------|------|-------|-------|----|
| P141014* | 14 | 4,0 | 0,55 | 28,35 | 1 |
| P141016* | 16 | 5,0 | 0,90 | 34,75 | 1 |
| P141020* | 20 | 5,5 | 1,50 | 37,60 | 20 |
| P141024 | 24 | 5,8 | 2,25 | 41,90 | 10 |
| P141028 | 28 | 7,5 | 4,00 | 54,15 | 1 |
| P141032 | 32 | 8,0 | 5,75 | 64,70 | 1 |
| P141036 | 36 | 8,5 | 7,75 | 82,60 | 5 |
| P141040 | 40 | 10,0 | 11,25 | 91,65 | 4 |

Deep casserole without lid

Cazuela alta sin tapa
Braising sans couvercle



Ground base
Fondo torneado
Fond dressé

| REF | Ø cm | H cm | Lts | €/u | |
|----------|------|------|-------|-------|----|
| P151012* | 12 | 8,5 | 0,85 | 30,00 | 12 |
| P151014* | 14 | 8,5 | 1,10 | 36,75 | 1 |
| P151016* | 16 | 8,0 | 1,40 | 38,15 | 12 |
| P151020 | 20 | 9,0 | 2,50 | 45,30 | 12 |
| P151024 | 24 | 10,0 | 4,00 | 54,90 | 6 |
| P151028 | 28 | 12,0 | 6,65 | 64,35 | 6 |
| P151032 | 32 | 14,0 | 10,00 | 83,40 | 3 |

Black Pro



Hot-plate with handles

Parrilla plana con asas
Grill plat avec poignées



| REF | W x D x H cm | €/u | |
|---------|--------------|-------|---|
| P153025 | 25 x 25 x 2 | 54,50 | 1 |

Hot-plate with handles

Parrilla plana con asas
Grill plat avec poignées



| REF | W x D x H cm | €/u | |
|---------|---------------|-------|---|
| P153034 | 34 x 26 x 2,5 | 78,30 | 6 |

Hot-plate with handles

Parrilla plana con asas
Grill plat avec poignées



| REF | W x D x H cm | €/u | |
|---------|---------------|--------|---|
| P153050 | 50 x 30 x 2,5 | 131,85 | 4 |

Roast pan

Rustidera
Plaque à rôtir



| REF | W x D x H cm | €/u | |
|----------|---------------|-------|----|
| P152025* | 25 x 20 x 6,5 | 49,75 | 10 |
| P152030 | 30 x 22 x 7 | 59,35 | 10 |
| P152035 | 35 x 25 x 7,5 | 75,45 | 5 |

Steel Expert

"Lyonnaise" Steel fry pan 1,5 mm

Sartén "Lionesa" 1,5 mm

Poêle "Lyonnaise" 1,5 mm



| REF | Ø cm | H cm | €/u | 📦 |
|---------|------|------|-------|---|
| P135120 | 20 | 4,5 | 12,70 | 1 |
| P135124 | 24 | 5,0 | 15,50 | 1 |
| P135128 | 28 | 5,5 | 20,05 | 1 |
| P135132 | 32 | 6,0 | 24,75 | 1 |
| P135140 | 40 | 7,0 | 40,20 | 1 |

Crêpe fry pan

Sartén para crêpes

Poêle à crêpes



| REF | Ø cm | H cm | €/u | 📦 |
|---------|------|------|-------|---|
| P135424 | 24 | 2,0 | 22,70 | 1 |



Spanish paella pan *Paellera / Plat à paella*

Black steel spanish paella pan

Paellera valenciana en acero pulido

Plat à paella tôle acier



| REF | Ø cm | Portions Raciones | €/u | 📦 |
|----------|------|----------------------|-------|---|
| P994020 | 20 | 1 | 6,35 | 1 |
| P994022 | 22 | 1 | 6,60 | 1 |
| P994024 | 24 | 1 | 7,10 | 1 |
| P994026 | 26 | 2 | 7,45 | 1 |
| P994030 | 30 | 4 | 8,55 | 1 |
| P994032 | 32 | 5 | 9,90 | 1 |
| P994034 | 34 | 6 | 10,40 | 1 |
| P994036 | 36 | 7 | 12,00 | 1 |
| P994038 | 38 | 8 | 12,55 | 1 |
| P994040 | 40 | 9 | 13,30 | 1 |
| P994042 | 42 | 10 | 15,45 | 1 |
| P994046 | 46 | 12 | 17,25 | 1 |
| P994050* | 50 | 14 | 20,40 | 1 |
| P994055* | 55 | 16 | 33,20 | 1 |
| P994065* | 65 | 22 | 49,55 | 1 |

Enamelled steel paella pan

Paellera acero esmaltado

Plat à paella acier émaillé



| REF | Ø cm | Portions Raciones | €/u | 📦 |
|-----------|------|----------------------|-------|---|
| P995010 * | 10 | - | 5,65 | 1 |
| P995016 * | 15 | - | 6,65 | 1 |
| P995020 | 20 | 2 | 8,95 | 1 |
| P995026 | 26 | 2 | 10,20 | 1 |
| P995030 | 30 | 4 | 12,75 | 1 |
| P995034 | 34 | 6 | 15,60 | 1 |
| P995036 | 36 | 7 | 18,90 | 1 |
| P995038 | 38 | 8 | 20,15 | 1 |
| P995040 | 40 | 9 | 22,70 | 1 |
| P995042 | 42 | 10 | 22,95 | 1 |
| P995050 | 50 | 14 | 35,05 | 1 |
| P995060 | 60 | 19 | 54,00 | 1 |

* Models also available in 3mm thickness.
Modelos también disponibles en 3mm de grosor.
Modèles également disponibles en épaisseur 3 mm

Deep enamelled fry pan with handles

Sartén honda esmaltada con asas

Poêle haute avec anses

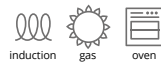

| REF | Ø cm | Lts | €/u | 📦 |
|-----------|------|------|-------|---|
| P997014 * | 14 | 0,40 | 6,00 | 1 |
| P997016 * | 16 | 0,50 | 6,50 | 1 |
| P997028 | 28 | 3,90 | 10,85 | 1 |
| P997032 | 32 | 5,30 | 13,70 | 1 |
| P997036 | 36 | 7,80 | 18,40 | 1 |
| P997040 | 40 | 9,40 | 23,30 | 1 |



Oven 50

Oven 90

Oven 140

Open Grill

Open Grill Lite

Robata

Until / Hasta / Jusqu'à

Ø 38 cm

Ø 46 cm

Ø 65 cm

Ø 50 cm

Ø 40 cm

Ø 30 cm

Cookware

Menaje
Batterie



Cast Iron miniatures

Miniaturas hierro fundido
Miniatures fonte émaillée



Mini fry pan

Mini sartén

Mini poêle ronde



| REF | Ø cm | L cm | H cm | €/u | |
|--------|------|------|------|------|----|
| P23500 | 10,5 | 16 | 2,6 | 6,60 | 12 |

Mini fry pan

Mini sartén

Mini poêle ronde



| REF | Ø cm | L cm | H cm | €/u | |
|--------|------|------|------|-------|----|
| P23501 | 13,5 | 21 | 2,5 | 10,35 | 12 |

Mini deep fry pan

Mini sartén alta

Mini poêle ronde haute



| REF | Ø cm | L cm | H cm | €/u | |
|--------|------|------|------|-------|----|
| P23502 | 14 | 23,5 | 3,8 | 15,50 | 12 |

Mini squared fry pan

Mini sartén cuadrada

Mini poêle carrée



| REF | W x D x H cm | L cm | €/u | |
|--------|-------------------|------|-------|----|
| P23503 | 13,6 x 13,6 x 3,6 | 23,3 | 16,75 | 12 |

Cookware

Menaje
Batterie

Mini oblong fry pan
Mini sartén rectangular
Mini poêle rectangulaire



| REF | W x D x H cm | L cm | € / u |  |
|--------|-------------------|------|-------|---|
| P23504 | 12,7 x 10,5 x 2,5 | 18 | 9,40 | 12 |

Oval casserole
Cacerola oval
Mini casserole ovale



| REF | W x D x H cm | Lts | € / u |  |
|--------|-------------------|------|-------|---|
| P23508 | 21,5 x 15,5 x 6,5 | 0,60 | 25,30 | 8 |

Mini round casserole with lid
Mini cacerola con tapa
Mini cocotte avec couvercle



| REF | Ø cm | L cm | H cm | Lts | € / u |  |
|--------|------|------|------|------|-------|---|
| P23505 | 10 | 13 | 7,5 | 0,20 | 20,30 | 12 |

High round casserole with lid
Cacerola alta con tapa
Cocotte haute avec couvercle



| REF | Ø cm | H cm | Lts | € / u |  |
|--------|------|------|------|-------|---|
| P23507 | 14 | 9,5 | 0,70 | 31,00 | 8 |

Mini oval pan with lid
Mini fuente oval con tapa
Mini plateau ovale avec couvercle



| REF | W x D x H cm | L cm | € / u |  |
|--------|--------------|------|-------|---|
| P23506 | 12 x 8 x 5 | 15,5 | 11,70 | 12 |

High mini oval pan with lid
Mini fuente oval alta con tapa
Mini plateau ovale haut avec couvercle



| REF | W x D x H cm | Lts | € / u |  |
|--------|------------------|------|-------|---|
| P23509 | 12,5 x 9,3 x 7,5 | 0,25 | 30,95 | 12 |

Cookware

Menaje
Batterie



Tin plates display

Llaunas presentació
Plateaux inox présentation

Stainless steel tray with handles

Llauna inox con asas
Plaques inox avec anses



P296415



P296515



P296615



P296715

| REF | Base cm | Total W x D x H cm | €/ u | |
|---------|------------|-----------------------|-------|---|
| P296415 | 22 x 14 | 25,5 x 14 x 1,5 | 19,00 | 1 |
| P296430 | 22 x 14 | 25,5 x 14 x 3 | 20,30 | 1 |
| P296515 | 26,5 x 23 | 30 x 23 x 1,5 | 22,05 | 1 |
| P296530 | 26,5 x 23 | 30 x 23 x 3 | 23,50 | 1 |
| P296615 | 32 x 24 | 35,5 x 24 x 1,5 | 23,60 | 1 |
| P296630 | 32 x 24 | 35,5 x 24 x 3 | 25,20 | 1 |
| P296715 | 32 x 18 | 35,5 x 18 x 1,5 | 21,55 | 1 |
| P296730 | 32 x 18 | 35,5 x 18 x 3 | 23,00 | 1 |

Cork base

Base de corcho
Base en liège



dishwasher



| REF | W x D x H cm | Suitable for Compatible con Adaptable pour | €/ u | |
|---------|---------------|--|-------|---|
| P926300 | 30 x 19 x 3 | P296415 - P296430 | 20,50 | 1 |
| P926400 | 34,5 x 28 x 3 | P296515 - P296530 | 30,65 | 1 |
| P926500 | 40 x 29 x 3 | P296615 - P296630 | 34,75 | 1 |
| P926600 | 40 x 23 x 3 | P296715 - P296730 | 30,00 | 1 |

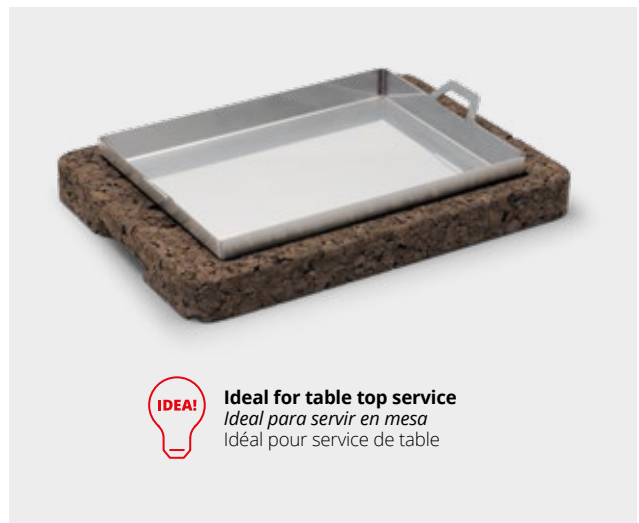

Ideal for table top service
Ideal para servir en mesa
Idéal pour service de table

Cookware

Menaje
Batterie

Stainless steel presentation spatula

Pala presentación en inox
Pelle de présentation en inox



| REF | Base cm | Total W x D x H cm | € / u | |
|--------|------------|-----------------------|-------|---|
| P29680 | 23 x 16 | 38,6 x 16 x 11,5 | 20,70 | 1 |

Triangular tray

Llauna triangular
Plaque triangulaire



| REF | W x D x H cm | € / u | |
|----------|---------------|-------|---|
| P2965001 | 29 x 29 x 1,5 | 26,95 | 1 |

Sheet pan with wooden tray with handle

Llauna bandeja presentación rectangular con mango
Plateau de présentation avec manche



dishwasher



| REF | Llauna W x D x H cm | Total W x D x H cm | € / u | |
|--------|------------------------|-----------------------|-------|---|
| P29610 | 22 x 14 x 2 | 34 x 18 x 3 | 39,35 | 6 |

Sheet pan with wooden tray

Llauna bandeja presentación rectangular
Plateau de présentation



dishwasher



| REF | Llauna W x D x H cm | Total W x D x H cm | € / u | |
|--------|------------------------|-----------------------|-------|---|
| P29600 | 29,5 x 19,5 x 2 | 33 x 23 x 3 | 40,05 | 6 |

1/1 GN sheet pan

Llauna bandeja gastronorm 1/1 presentación
Plateau GN 1/1 de présentation



GN 1/1



| REF | Llauna W x D x H cm | Total L cm | € / u | |
|---------|------------------------|---------------|-------|---|
| P195000 | 48 x 32 x 2 | 52,5 | 46,80 | 6 |

Round sheet pan with wooden tray

Llauna bandeja presentación redonda
Plateau rond de présentation



dishwasher



| REF | Llauna Ø cm | H cm | Total L cm | H cm | € / u | |
|--------|----------------|------|---------------|------|-------|---|
| P29620 | 20 | 4,5 | 31 | 5,5 | 39,65 | 6 |
| P29630 | 26 | 4,5 | 37 | 5,5 | 48,55 | 6 |

Cookware

Menaje
Batterie



Bronze cookware

Llaunas presentación
Plateaux inox présentation



Rotisserie
Rustidera
Plat à rôtir



| REF | W x D x H cm | € / u | |
|-----------------|---|-------|---|
| P152035B | 35 x 25 x 7,5 | 79,20 | 1 |
| P152935 | Transparent lid Tapa transparente Couvercle transparent | 20,70 | 1 |

Shallow casserole without lid
Cazuela baja sin tapa
Cocotte sans couvercle



| REF | Ø cm | H cm | € / u | |
|-----------------|------|------|-------|---|
| P141024B | 24 | 5,8 | 43,95 | 1 |
| P141028B | 28 | 7,5 | 56,85 | 1 |
| P141032B | 32 | 8,0 | 67,95 | 1 |

Deep casserole without lid
Cazuela alta sin tapa
Braisière sans couvercle



| REF | Ø cm | H cm | € / u | |
|-----------------|------|------|-------|---|
| P151020B | 20 | 9 | 47,60 | 1 |
| P151024B | 24 | 10 | 57,65 | 1 |
| P151028B | 28 | 12 | 67,55 | 1 |

Glass lid with stainless steel rim
Tapa de cristal con borde de acero inoxidable
Couvercle en verre avec rebord en acier inoxydable



| REF | Ø cm | € / u | |
|----------------|------|-------|---|
| P154020 | 20 | 9,85 | 1 |
| P154024 | 24 | 11,10 | 1 |
| P154028 | 28 | 12,30 | 1 |
| P154032 | 32 | 13,55 | 1 |

Economical oval serving dish with rolled edge
Fuente oval borde vuelto económica
Plat ovale à bords ronds économique



Mirror finished
Pulido brillante
Polissage brillant



| REF | cm | € / u | |
|----------------|-----------|-------|----|
| P317425 | 25 x 17,5 | 7,75 | 60 |
| P317430 | 30 x 21,0 | 8,70 | 60 |
| P317435 | 35 x 24,0 | 10,35 | 60 |
| P317440 | 40 x 26,5 | 11,40 | 40 |
| P317445 | 45 x 29,5 | 13,90 | 30 |
| P317450 | 50 x 34,0 | 17,75 | 24 |

Enamelled steel miniatures

Miniaturas acero esmaltado

Miniatures acier émaillé



Casserole with lid

Cazuela con tapa

Cocotte avec couvercle



| REF | Ø cm | H cm | €/u | | |
|---------|------|------|-------|---|--|
| P998010 | 10 | 6,0 | 14,95 | 1 | |
| P998012 | 12 | 4,0 | 17,45 | 1 | |
| P998014 | 14 | 4,5 | 19,90 | 1 | |

Shallow casserole without lid

Cazuela baja sin tapa

Cocotte sans couvercle



| REF | Ø cm | H cm | €/u | | |
|---------|------|------|-------|---|--|
| P999012 | 12 | 6,5 | 9,95 | 1 | |
| P999014 | 14 | 7,0 | 11,95 | 1 | |

Cast aluminium miniatures

Miniaturas aluminio de fundición

Miniatures fonte d'aluminium

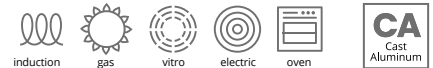

Mini casserole with lid

Mini cazuela con tapa

Mini cocotte avec couvercle



Wooden base included

Base de madera incluida.

Base en bois incluse

| REF | Ø cm | H cm | | €/u | |
|---------|------|------|---|-------|---|
| P151100 | 10 | 5 | ● | 21,55 | 1 |
| P151300 | 10 | 5 | ● | 21,55 | 1 |

Mini oval casserole with lid

Mini cazuela oval con tapa

Mini cocotte ovale avec couvercle



Wooden base included

Base de madera incluida.

Base en bois incluse

| REF | W x D x H cm | | €/u | | |
|---------|---------------|---|-------|---|--|
| P151200 | 13 x 10,5 x 5 | ● | 22,95 | 1 | |
| P151400 | 13 x 10,5 x 5 | ● | 22,95 | 1 | |

Melamine for presentation



Melamina presentación
Melamine présentation



Kitchen utensils

Utensilios de cocina / Ustensiles de cuisine



Oven and roast pans

Horno y rustideras / Four et plaques à rôtir





Technical information

Información técnica / Information technique

Technical information

Información técnica
Information technique

Charcoal Oven 50 with table

Horno de brasa 50 con mesa

Four à braise 50 avec table

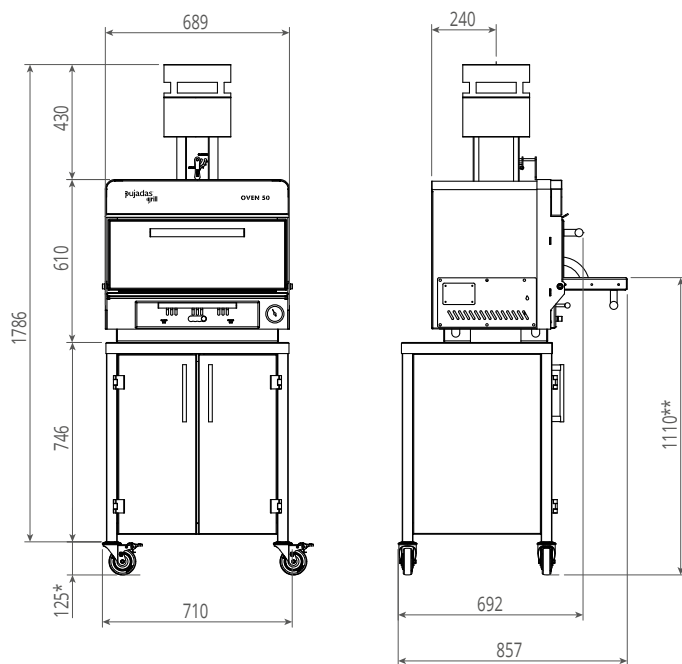

Total net weight
Peso neto total 200 Kg
Poids net total

Measurements and weight with packaging
Medidas y peso con embalaje
Dimensions et poids avec emballage

| | Kg | cm W x D x H |
|--|-----|---------------|
| Oven Horno Four | 180 | 78 x 65 x 80 |
| Lower table Mesa inferior Table inférieure | 40 | 120 x 80 x 88 |
| Upper draught regulator Regulador tiro sup. Rég. de tirage sup. | 3 | 20 x 20 x 23 |
| External firewal Cortafuegos externo Coupe-feu extérieur | 4 | 25 x 25 x 24 |
| Hat filter Filtro sombrero Filtre chapeau | 2 | 25 x 25 x 13 |

* **Height adjustable feet 50 mm**
* Altura pies regulables 50 mm
* Hauteur pieds réglables 50 mm

** **Height with adjustable feet 103.5cm**
** Altura con pies regulables 103,5 cm
** Hauteur avec pieds réglables 103,5 cm

Charcoal Oven 50

Horno de brasa 50

Four à braise 50

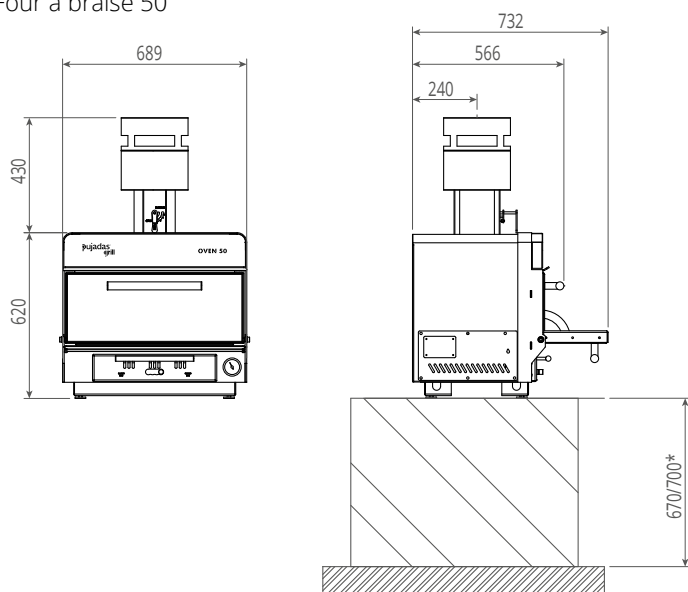

Total net weight
Peso neto total 169 Kg
Poids net total

Measurements and weight with packaging
Medidas y peso con embalaje
Dimensions et poids avec emballage

| | Kg | cm W x D x H |
|--|-----|--------------|
| Oven Horno Four | 180 | 78 x 65 x 80 |
| Upper draught regulator Regulador tiro sup. Rég. de tirage sup. | 3 | 20 x 20 x 23 |
| External firewal Cortafuegos externo Coupe-feu extérieur | 4 | 25 x 25 x 24 |
| Hat filter Filtro sombrero Filtre chapeau | 2 | 25 x 25 x 13 |

* **Recommended table height to ensure the perfect use of the machine.**

* *Altura recomendada de la mesa para el perfecto uso de la máquina.*

* *Hauteur de table recommandée pour une utilisation idéale de la machine.*

IMPORTANT!

- Installation on a steel table is recommended.
- Installation on wooden or ceramic worktops is not recommended.

¡IMPORTANTE!

- Se recomienda su instalación sobre mesa de acero.
- No se recomienda la instalación sobre encimeras de madera o cerámica.

IMPORTANT !

- Il est recommandé de l'installer sur une table en acier.
- L'installation sur des plans de travail en bois ou en céramique n'est pas recommandée.

Technical information

Información técnica
Information technique

Charcoal Oven 90 with table

Horno de brasa 90 con mesa

Four à braise 90 avec table

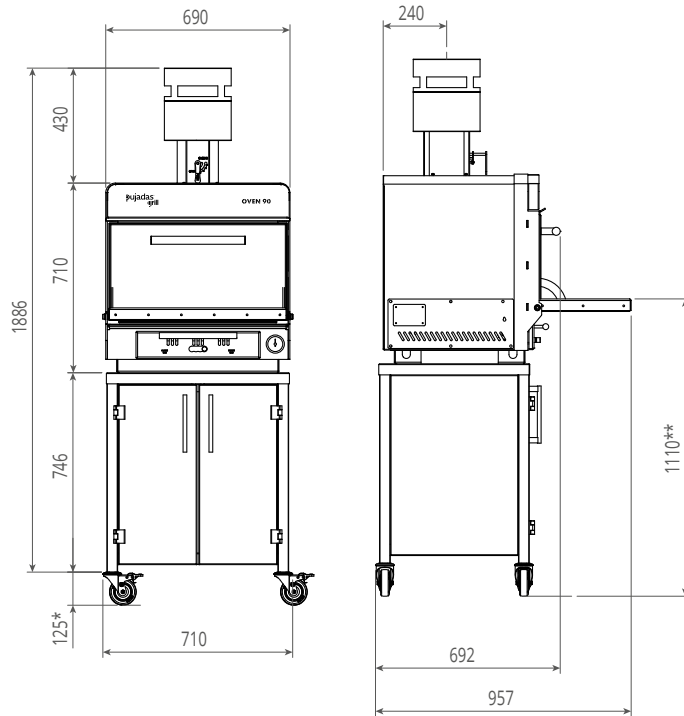

Total net weight
Peso neto total 240 Kg
Poids net total

Measurements and weight with packaging
Medidas y peso con embalaje
Dimensions et poids avec emballage

| | Kg | cm W x D x H |
|--------------------------------|-----|----------------|
| Oven | | |
| Horno | 230 | 78 x 75 x 90 |
| Four | | |
| Lower table | | |
| Mesa inferior | 40 | 120 x 80 x 88 |
| Table inférieure | | |
| Upper draught regulator | | |
| Regulador tiro sup. | 3 | 20 x 20 x 23 |
| Rég. de tirage sup. | | |
| External firewal | | |
| Cortafuegos externo | 4 | 25 x 25 x 24 |
| Coupe-feu extérieur | | |
| Hat filter | | |
| Filtro sombrero | 2 | 25 x 25 x 12,5 |
| Filtre chapeau | | |

* Height adjustable feet 50 mm

* Altura pies regulables 50 mm

* Hauteur pieds réglables 50 mm

** Altura con pies regulables 103,5 cm

** Altura con pies regulables 103,5 cm

** Hauteur avec pieds réglables 103,5 cm

Charcoal Oven 90

Horno de brasa 90

Four à braise 90

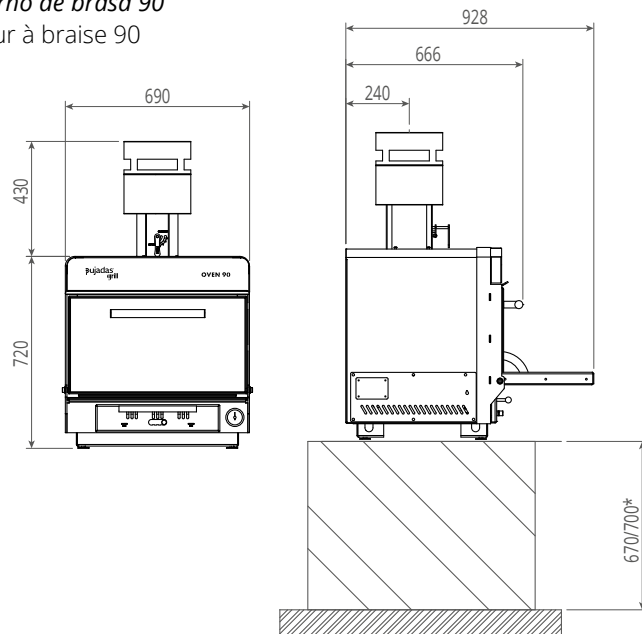

Total net weight
Peso neto total 210 Kg
Poids net total

Measurements and weight with packaging
Medidas y peso con embalaje
Dimensions et poids avec emballage

| | Kg | cm W x D x H |
|--------------------------------|-----|--------------|
| Oven | | |
| Horno | 230 | 78 x 75 x 90 |
| Four | | |
| Upper draught regulator | | |
| Regulador tiro sup. | 3 | 20 x 20 x 23 |
| Rég. de tirage sup. | | |
| External firewal | | |
| Cortafuegos externo | 4 | 25 x 25 x 24 |
| Coupe-feu extérieur | | |
| Hat filter | | |
| Filtro sombrero | 2 | 25 x 25 x 13 |
| Filtre chapeau | | |

* Recommended table height to ensure the perfect use of the machine.

* Altura recomendada de la mesa para el perfecto uso de la máquina.

* Hauteur de table recommandée pour une utilisation idéale de la machine.

IMPORTANT!

- Installation on a steel table is recommended.
- Installation on wooden or ceramic worktops is not recommended.

¡IMPORTANTE!

- Se recomienda su instalación sobre mesa de acero.
- No se recomienda la instalación sobre encimeras de madera o cerámica.

IMPORTANT!

- Il est recommandé de l'installer sur une table en acier.
- L'installation sur des plans de travail en bois ou en céramique n'est pas recommandée.

Technical information

Información técnica
Information technique

Charcoal Oven 140 with table

Horno de brasa 140 con mesa

Four à braise 140 avec table

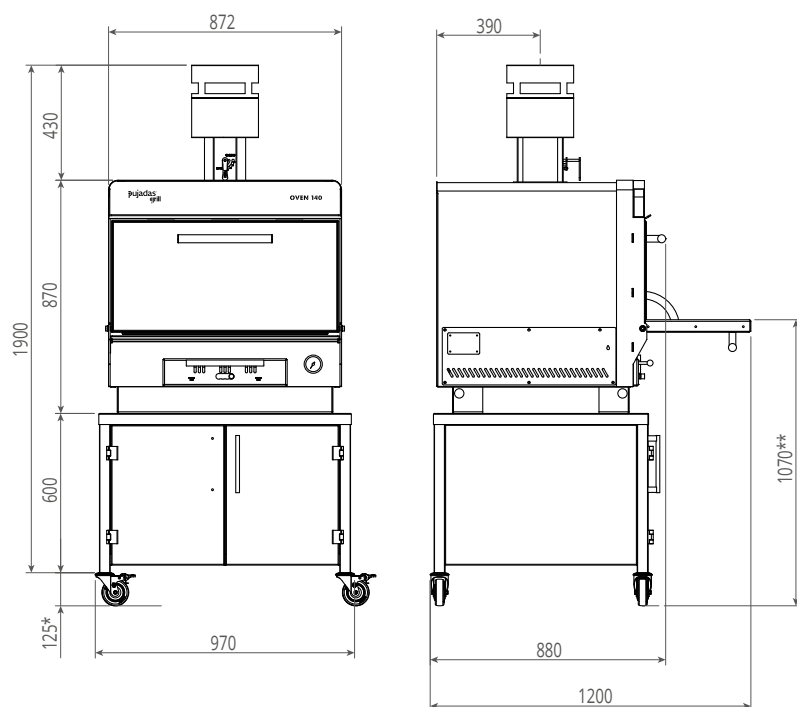

Total net weight
Peso neto total 350 Kg
Poids net total

Measurements and weight with packaging
Medidas y peso con embalaje
Dimensions et poids avec emballage

| | Kg | cm W x D x H |
|--|-----|---------------|
| Oven Horno Four | 350 | 94 x 96 x 108 |
| Lower table Mesa inferior Table inférieure | 40 | 120 x 80 x 88 |
| Upper draught regulator Regulador tiro sup. Rég. de tirage sup. | 3 | 20 x 20 x 23 |
| External firewal Cortafuegos externo Coupe-feu extérieur | 4 | 25 x 25 x 24 |
| Hat filter Filtro sombrero Filtre chapeau | 2 | 25 x 25 x 13 |

* Height adjustable feet 50 mm
* Altura pies regulables 50 mm
* Hauteur pieds réglables 50 mm

** Altura con pies regulables 99,5 cm
** Altura con pies regulables 99,5 cm
** Hauteur avec pieds réglables 99,5 cm

Charcoal Oven 140

Horno de brasa 140

Four à braise 140

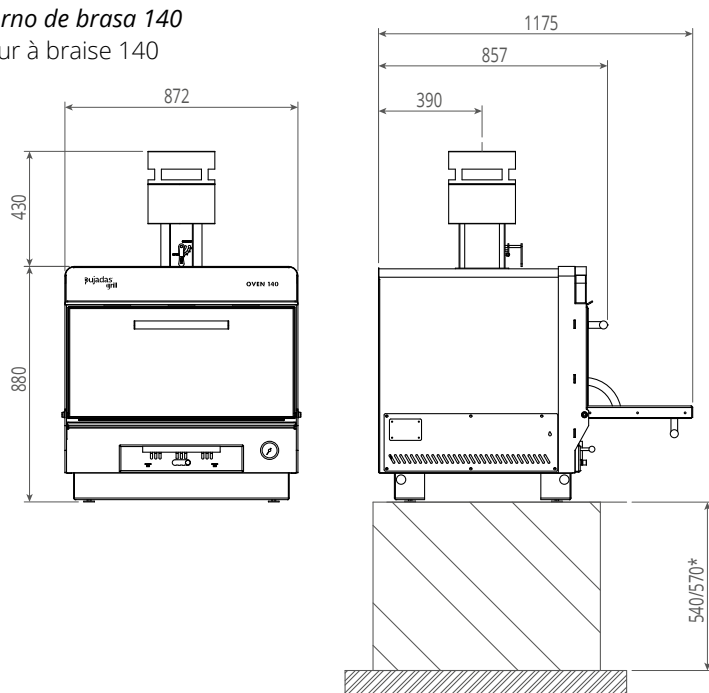

Total net weight
Peso neto total 320 Kg
Poids net total

Measurements and weight with packaging
Medidas y peso con embalaje
Dimensions et poids avec emballage

| | Kg | cm W x D x H |
|--|-----|---------------|
| Oven Horno Four | 350 | 94 x 96 x 108 |
| Upper draught regulator Regulador tiro sup. Rég. de tirage sup. | 3 | 20 x 20 x 23 |
| External firewal Cortafuegos externo Coupe-feu extérieur | 4 | 25 x 25 x 24 |
| Hat filter Filtro sombrero Filtre chapeau | 2 | 25 x 25 x 13 |

* Recommended table height to ensure the perfect use of the machine.

* Altura recomendada de la mesa para el perfecto uso de la máquina.

* Hauteur de table recommandée pour une utilisation idéale de la machine.

IMPORTANT!

- Installation on a steel table is recommended.
- Installation on wooden or ceramic worktops is not recommended.

¡IMPORTANTE!

- Se recomienda su instalación sobre mesa de acero.
- No se recomienda la instalación sobre encimeras de madera o cerámica.

IMPORTANT!

- Il est recommandé de l'installer sur une table en acier.
- L'installation sur des plans de travail en bois ou en céramique n'est pas recommandée.

Technical information

Información técnica
Information technique

Open grill

Brasa abierta

Grill ouvert

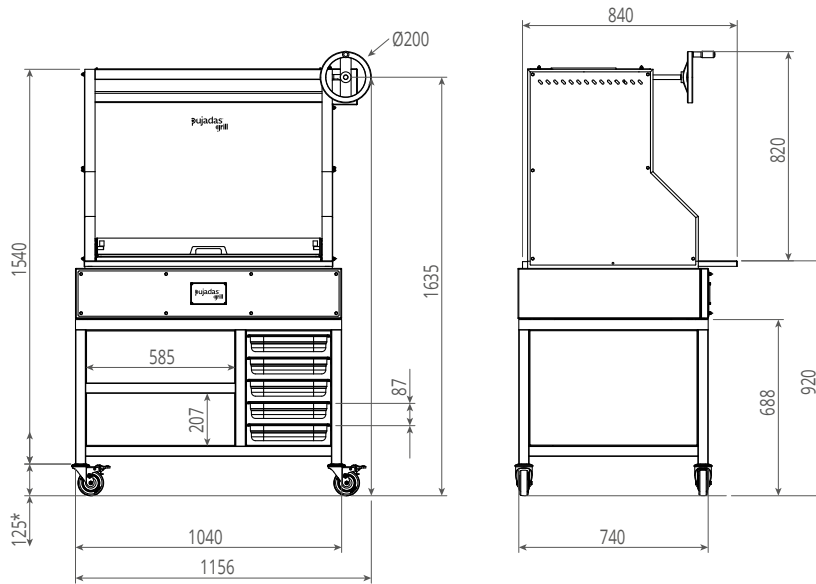

Total net weight

Peso neto total 365 Kg
Poids net total

Measurements and weight with packaging

Medidas y peso con embalaje
Dimensions et poids avec emballage

| | Kg | cm W x D x H |
|--|-----|---------------|
| Upper module Módulo superior Module supérieur | 170 | 115 x 91 x 93 |
| Refractory base Base refractaria Base réfractaire | 200 | 113 x 85 x 36 |
| Lower table Mesa inferior Table inférieure | 65 | 120 x 80 x 80 |
| Grill Parrilla Gril | 10 | 86 x 54 x 3 |
| No. of bricks Nº de tochos Nb de briques | 38u | 22 x 11 x 3 |

* Height adjustable feet 50 mm

* Altura pies regulables 50 mm

* Hauteur pieds réglables 50 mm

Open grill table top

Brasa abierta de sobremesa

Grill ouvert de table

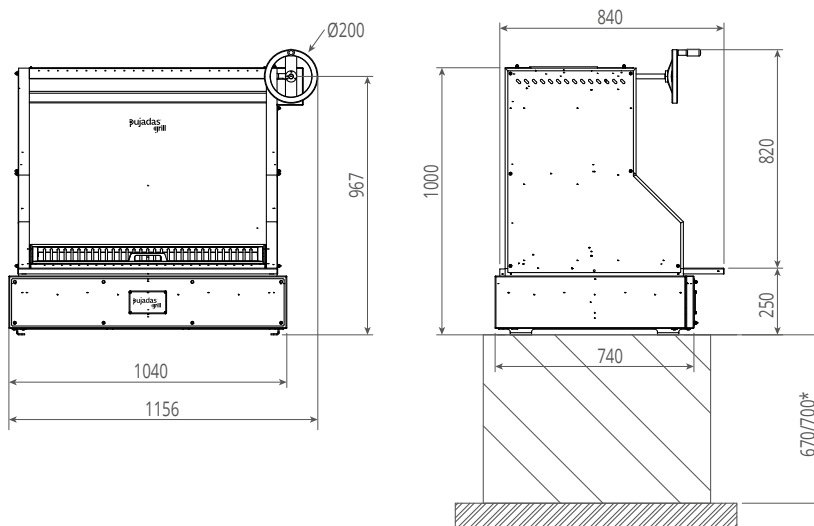

Total net weight

Peso neto total 310 Kg
Poids net total

Measurements and weight with packaging

Medidas y peso con embalaje
Dimensions et poids avec emballage

| | Kg | cm W x D x H |
|--|-----|---------------|
| Upper module Módulo superior Module supérieur | 170 | 115 x 91 x 93 |
| Refractory base Base refractaria Base réfractaire | 200 | 113 x 85 x 36 |
| Grill Parrilla Gril | 10 | 86 x 54 x 3 |
| No. of bricks Nº de tochos Nb de briques | 38u | 22 x 11 x 3 |

* Recommended table height to ensure the perfect use of the machine.

* Altura recomendada de la mesa para el perfecto uso de la máquina.

* Hauteur de table recommandée pour une utilisation idéale de la machine.

IMPORTANT!

- Installation on a steel table is recommended.
- Installation on wooden or ceramic worktops is not recommended.

¡IMPORTANTE!

- Se recomienda su instalación sobre mesa de acero.
- No se recomienda la instalación sobre encimeras de madera o cerámica.

IMPORTANT!

- Il est recommandé de l'installer sur une table en acier.
- L'installation sur des plans de travail en bois ou en céramique n'est pas recommandée.

Technical information

Información técnica
Information technique

Open grill without refractory base

Brasa abierta sin base refractaria

Grill ouvert sans base réfractaire

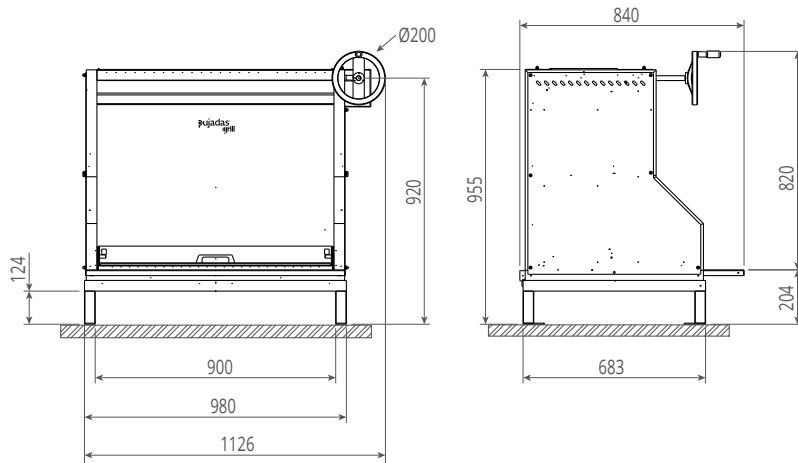

IMPORTANT!

- Installation on concrete/refractory brick base is recommended.

¡IMPORTANTE!

- Se recomienda su instalación sobre base de cemento / ladrillo refractario

¡IMPORTANTE!

- Se recomienda su instalación sobre base de cemento / ladrillo refractario

Total net weight

Peso neto total 150 Kg
Poids net total

Measurements and weight with packaging

Medidas y peso con embalaje
Dimensions et poids avec emballage

| | Kg | cm W x D x H |
|--|-----|---------------|
| Upper module Módulo superior Module supérieur | 170 | 115 x 91 x 93 |
| Tubular base Base tubular Base tubulaire | 10 | 100 x 70 x 18 |
| Grill Parrilla Gril | 10 | 86 x 54 x 3 |

Open grill lite

Brasa abierta lite

Grill ouvert lite

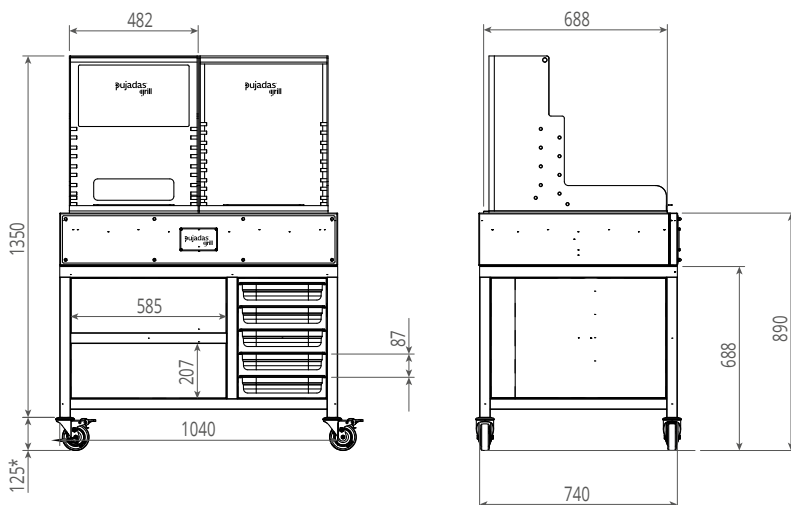

Total net weight

Peso neto total 255 Kg
Poids net total

Measurements and weight with packaging

Medidas y peso con embalaje
Dimensions et poids avec emballage

| | Kg | cm W x D x H |
|--|-----|-----------------|
| Upper module Módulo superior Module supérieur | 30 | 49 x 58 x 67 /u |
| Refractory base Base refractaria Base réfractaire | 200 | 113 x 85 x 36 |
| Lower table Mesa inferior Table inférieure | 65 | 120 x 80 x 80 |
| Grill Parrilla Gril | 5 | 77 x 47 x 3 |
| No. of bricks Nº de tochos Nb de briques | 38u | 22 x 11 x 3 |

* Height adjustable feet 50 mm

* Altura pies regulables 50 mm

* Hauteur pieds réglables 50 mm

Technical information

Información técnica
Information technique

Open grill lite table top

Brasa abierta lite de sobremesa

Grill ouvert lite de table

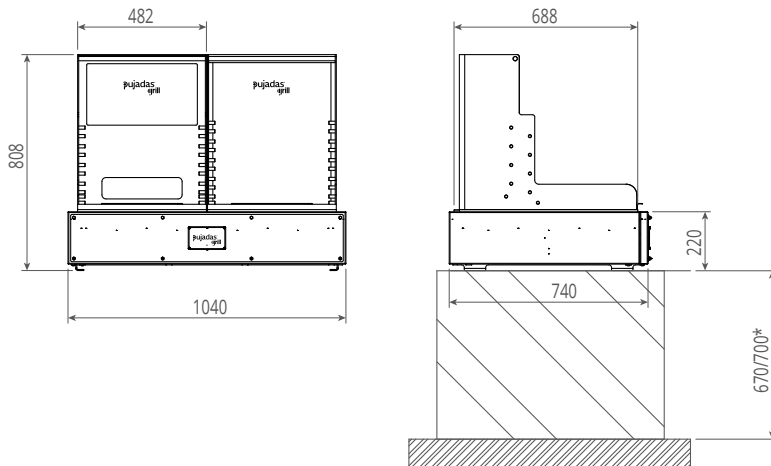

IMPORTANT!

- Installation on a steel table is recommended.
- Installation on wooden or ceramic worktops is not recommended.

¡IMPORTANTE!

- Se recomienda su instalación sobre mesa de acero.
- No se recomienda la instalación sobre encimeras de madera o cerámica.

IMPORTANT !

- Il est recommandé de l'installer sur une table en acier.
- L'installation sur des plans de travail en bois ou en céramique n'est pas recommandée.

Total net weight

Peso neto total 200 Kg
Poids net total

Measurements and weight with packaging

Medidas y peso con embalaje
Dimensions et poids avec emballage

| | Kg | cm W x D x H |
|--|-----|-----------------|
| Upper module Módulo superior Module supérieur | 30 | 49 x 58 x 67 /u |
| Refractory base Base refractaria Base réfractaire | 200 | 113 x 85 x 36 |
| Grill Parrilla Gril | 5 | 77 x 47 x 3 |
| No. of bricks Nº de tochos Nb de briques | 38u | 22 x 11 x 3 |

* Recommended table height to ensure the perfect use of the machine.

* Altura recomendada de la mesa para el perfecto uso de la máquina.

* Hauteur de table recommandée pour une utilisation idéale de la machine.

Open grill lite without refractory base

Brasa abierta lite sin base refractaria

Grill ouvert lite sans base réfractaire

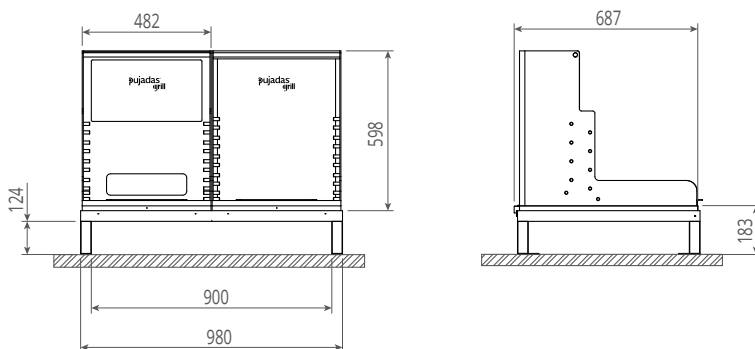

IMPORTANT!

- Installation on concrete/refractory brick base is recommended.

¡IMPORTANTE!

- Se recomienda su instalación sobre base de cemento / ladrillo refractario

¡IMPORTANTE!

- Se recomienda su instalación sobre base de cemento / ladrillo refractario

Total net weight

Peso neto total 70 Kg
Poids net total

Measurements and weight with packaging

Medidas y peso con embalaje
Dimensions et poids avec emballage

| | Kg | cm W x D x H |
|--|----|-----------------|
| Upper module Módulo superior Module supérieur | 30 | 49 x 58 x 67 /u |
| Tubular base Base tubular Base tubulaire | 10 | 113 x 85 x 36 |
| Grill Parrilla Gril | 5 | 77 x 47 x 3 /u |

Technical information

Información técnica
Information technique



Robata

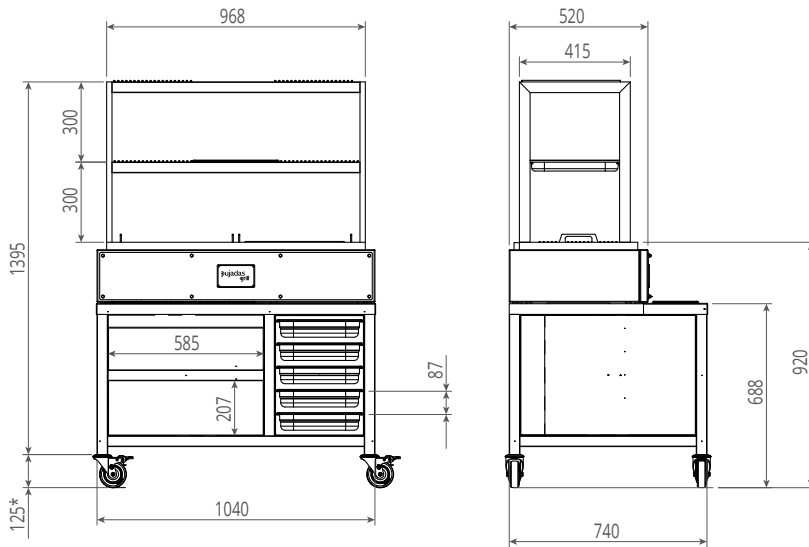

Total net weight
Peso neto total 195 Kg
Poids net total

Measurements and weight with packaging
Medidas y peso con embalaje
Dimensions et poids avec emballage

| | Kg | cm W x D x H |
|--|-----|---------------|
| Upper module Módulo superior Module supérieur | 30 | 97 x 44 x 64 |
| Refractory base Base refractaria Base réfractaire | 150 | 113 x 85 x 36 |
| Lower table Mesa inferior Table inférieure | 65 | 120 x 80 x 80 |
| No. of bricks Nº de tochos Nb de briques | 28u | 22 x 11 x 3 |

* Height adjustable feet 50 mm
* Altura pies regulables 50 mm
* Hauteur pieds réglables 50 mm

Robata table top

Robata de sobremesa
Robata de table

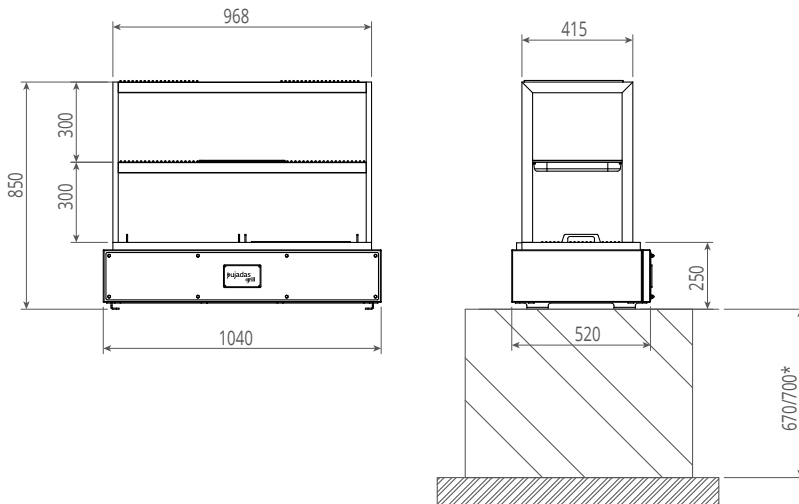

Total net weight
Peso neto total 140 Kg
Poids net total

Measurements and weight with packaging
Medidas y peso con embalaje
Dimensions et poids avec emballage

| | Kg | cm W x D x H |
|--|-----|---------------|
| Upper module Módulo superior Module supérieur | 30 | 97 x 44 x 64 |
| Refractory base Base refractaria Base réfractaire | 150 | 113 x 85 x 36 |
| No. of bricks Nº de tochos Nb de briques | 28u | 22 x 11 x 3 |

* Recommended table height to ensure the perfect use of the machine.

* Altura recomendada de la mesa para el perfecto uso de la máquina.

* Hauteur de table recommandée pour une utilisation idéale de la machine.

IMPORTANT!

- Installation on a steel table is recommended.
- Installation on wooden or ceramic worktops is not recommended.

¡IMPORTANTE!

- Se recomienda su instalación sobre mesa de acero.
- No se recomienda la instalación sobre encimeras de madera o cerámica.

IMPORTANT!

- Il est recommandé de l'installer sur une table en acier.
- L'installation sur des plans de travail en bois ou en céramique n'est pas recommandée.

gruporoig.es

Grupo Roig

Polígono Industrial A Tomada, nº 61
15940 A Pobra do Caramiñal
(A Coruña)

☎ 981 832 321

✉ gruporoig@gruporoig.es

[@gruporoig](#)

roig
grupo